



STAFF REPORT

CITY OF TUALATIN

TO: Honorable Mayor and Members of the City Council

THROUGH: Sherilyn Lombos

FROM: William Harper, Senior Planner
Alice Cannon Rouyer, Assistant City Manager

DATE: 07/22/2013

SUBJECT: Consideration of a Central Urban Renewal District Master Plan for the Nyberg Rivers Shopping Center Development located at 7455-7925 SW Nyberg Street (Tax Map (2S124A 2700--2S124A 1601,1602, 1900, 2502, 2506, 2507, 2700/ 2S124B 2000, 2001, 2100) in the Central Commercial (CC), Commercial Office (CO) and High-Density Residential (RH) Planning Districts and Central Urban Renewal District Blocks 1-5.

ISSUE BEFORE THE COUNCIL:

The Council is considering a proposed Nyberg Rivers Master Plan submitted by CenterCal Properties, LLC to redevelop the former KMart site and associated properties on Central Urban Renewal District (CURD) Blocks 1, 2, 3, 4, and 5. The Central Urban Renewal Plan is adopted as a part of the Tualatin Development Code (TDC 30.010) and requires approval of a master plan prior to development or redevelopment on the site. The CURD Plan also states that a master plan shall contain sufficient information to ensure that development meets the objectives of the Plan. The Council should consider if the Nyberg Rivers proposal meets the goals and objectives of the CURD Plan.

RECOMMENDATION:

Staff recommends that the City Council consider the staff report and supporting attachments, and direct staff to prepare a resolution in support of the Council's recommendation on Master Plan MP-13-01.

EXECUTIVE SUMMARY:

This matter is a quasi-judicial public hearing to review a Master Plan in the Central Urban Renewal District.

Master Plan Application

On April 23, 2013, CenterCal Properties, LLC submitted an application for the Nyberg Rivers Master Plan and a Conditional Use Permit included as Attachment 102A-Master Plan Exhibit A, 102B-Master Plan Application and Attachment 102C- Master Plan Presentation. On May 22, 2013, the application was deemed complete and staff provided early feedback on the proposal to the applicant. In response to this feedback, the applicant submitted Addendum #1 on June 24, 2013 included as Attachment 102D. The Addendum provided updated plans and a response to issues and questions raised by Staff during the application review process.

Summary of Proposal

CenterCal Properties, LLC, owners of the Bridgeport Village and Nyberg Woods retail centers, submitted a Master Plan application (MP-13-01) and Conditional Use Permit (CUP-13-04) for the "Nyberg Rivers" commercial center project proposal to redevelop the former Kmart site and adjacent properties. Attachment 101 is a Vicinity Map for the Nyberg Rivers site. A proposed site plan is included as Attachment 102A. The proposed redevelopment will encompass a net development area of approximately 26 acres on the 32 acre Primary Development Area. The proposal includes demolition of three existing buildings (including the former Kmart building, the Wendy's Restaurant, and the Jiggles Restaurant), construction of seven (7) new buildings (treating attached tenant buildings 1005, 1010 and 1030 as one building), access and public facilities improvements, parking, pedestrian, bicycle, and landscaping improvements. Five existing buildings including the Michael's store building, the US Bank building, Banner Bank building, and the Multi-tenant Buildings A and B will remain.

CenterCal has also submitted an application for a proposed Conditional Use Permit (reviewed in a separate hearing as CUP-13-04) to apply to the Nyberg Rivers project to allow retail uses in the Office Commercial (CO) Planning District and allow outside sales in the Central Commercial (CC) Planning District.

Applicant's Requested Items

The applicant is requesting approval of certain items as part of the Master Plan (See Attachment 102D, pg 5.). Some of these items are not within the purview of the Master Plan decision and must either be decided through a separate land use process, requires a real property transaction, or other separate actions. CenterCal's requested items are set forth below, with staff's explanation of whether the item is within the purview of the Master Plan decision and which Goal(s) of the CURD Plan relates to each item.

1. Approve the general site layout and land uses as part of the Master Plan.

Staff's comments: A determination of whether to approve the general site layout is part of the Master Plan decision and addressed in Goals 1, 4 and 11 below.

The land uses are dictated by the Tualatin Development Code and not within the purview of the Master Plan.

2. Allow parking serving commercial and non-residential parking in the High Density Residential (RH) designated portions of the property.

Staff comments: A determination of whether to approve the proposed parking is part of the Master Plan decision and addressed under Goals 2, 4 and 11.

3. Allow up to 307,000 sf of building area on the property.

Staff comments: A determination of whether to approve 307,000 square feet of building areas is part of the Master Plan decision and addressed under Goal 1.

4. Secure the Master Plan approval for Blocks 1, 2, 3, 4, & 5.

Staff comments: A determination of whether to approve the Master Plan for CURD Blocks 1, 2, 3, 4, & 5 is part of the Master Plan decision and addressed under Goals 1 through 11.

5. Allow one new (Bldg H-100) and one relocated (F-100) drive-thru restaurant service window within the Central Commercial (CC) designated portions of the property.

Staff comments: A determination of whether to approve the proposed one new (Bldg H-100) and one relocated (F-100) drive-thru restaurant service window is part of the Master Plan decision and addressed under Goal 11.

6. Accept a shared pathway easement along the Tualatin River to allow for a future public trail.

Staff comments: A determination of whether to approve the location of the shared pathway along the Tualatin River is part of the Master Plan decision and addressed in Goals 4, 6 and 9.

Whether the shared pathway should be provided through an easement or another property transfer is not within the purview of the Master Plan. That is subject to the Tualatin Development Code, negotiation, and separate land use decisions.

7. Allow Street "A", the east-west storefront drive and the north-south divided drive to satisfy the Transportation System Plan (TSP) future minor collector connections over the property.

Staff comments: A decision on the location and standards of streets is part of the Master Plan decision and addressed under Goal 5.

8. Allow all plant material listed in the Master Plan in addition to all species otherwise approved by the City.

Staff comments: A decision about the style of landscaping and the type of plant material used is part of the Master Plan decision and addressed under Goal 11.

9. Approval of the approach and design for landscaping, including minimum landscape dimensions of 5-feet and general locations as shown on the Master Plan.

Staff comments: A decision about the style of landscaping and the type of plant material used is part of the Master Plan decision and addressed under Goal 11.

10. Approve the proposed street designs which are provided as separate cross-section exhibits.

Staff comments: A decision about the look and design is part of the Master Plan decision and addressed under Goal 5.

11. Allow the style and materials for building elevations as generally depicted in the Master Plan.

Staff comments: A decision about the style and materials for buildings and building elevations is part of the Master Plan decision and addressed under Goal 11.

12. Approval of the parking lot landscape diamonds as designed and shown on the “Enlargement C” exhibit within the Landscaping Theming Plan included in the Nyberg Rivers Master Plan.

Staff comments: A decision about whether to allow parking lot landscape "diamond" planters is part of the Master Plan decision and addressed under Goal 11.

13. Adopt/approve the development standards (dimensional) as listed in the Master Plan and apply to all future development on the site.

Staff comments: A decision on whether to approve proposed development standards is part of the Master Plan decision and addressed under Goals 1, 5 and 11.

14. Approve the review procedure as defined in the Master Plan.

Staff comments: A decision on whether to adopt a separate review procedure is not part of the Master Plan decision.

15. Approve and permit retail uses within the Office Commercial (CO) designated portions of the property.

Staff comments: A decision on whether to permit retail uses within the CO Planning District is not part of the Master Plan decision. The land uses are specified in the Tualatin Development Code. CenterCal has applied for a Conditional Use Permit which is the proper venue for making such a decision.

16. Approve right-of-way vacation of the Oregon Department of Transportation property along Nyberg Road.

Staff comments: A decision on matters of ODOT property is not part of the Master Plan decision.

Site Description

The properties are in the Central Commercial (CC) Planning District, the Commercial Office (CO) Planning District and a small portion of the High Density Residential (RH) Planning District. The Nyberg Rivers site encompasses Central Urban Renewal District (CURD) Blocks 1,2,3, and portions of 4. Block 5 is the City of Tualatin Library/City Hall campus property. The Nyberg Rivers site is at the northwest corner of the I-5 Freeway Exit 289/ Nyberg interchange. It has extensive frontage along I-5 and includes frontage along the Tualatin River Greenway. Attachment 101 is a Vicinity Map.

The proposed redevelopment project will be located on the former KMart/Schatz Furniture shopping center, on a portion of the undeveloped area north of KMart (Tax Lot 2700), on the Jiggles restaurant site (tax lots 2508 & 2502) and a segment of Oregon Department of Transportation property. The proposed redevelopment will encompass a net development area of approximately 26 acres of the 32 acre Primary Development Area. Attachment 102A shows the Master Plan area.

The subject site is located on the eastern edge of downtown Tualatin. The City Hall and Library campus directly abut the site and the Lake of the Commons is nearby on the westerly edge. The Fred Meyer shopping center and the recently installed gateway feature are located to the south of the site. The Tualatin River makes up the northern edge of the site along with an existing multi-family residential development. Tualatin-Sherwood Road and Nyberg Road directly abut the site to the south and will provide the primary access to the development. Martinazzi Avenue is to the west of the site and Boones Ferry Road is

to the north of the site. Both of these streets are intended to provide secondary access to the development.

Public Involvement

Neighbor-Developer Meeting. The applicant conducted a neighborhood/developer meeting on March 20, 2013 to explain the proposal to neighboring property owners and to receive comments. The meeting was well attended by the community and numerous comments were collected. (Attachment 102B, Exhibit H). Comments from Citizen Involvement Organizations (CIOs) are also included in Attachment 107.

Tualatin Parks Advisory Committee Meeting. The Tualatin Parks Advisory Committee (TPARK) reviewed the proposed Master Plan at their June 18, 2013 meeting. TPARK comments are summarized in Attachment 107 TPARK Summary & Minutes. TPARK provided comments regarding the extent of which the proposed Nyberg Rivers Master Plan achieves the goals of the Central Urban Renewal District Plan, Goal 6 Pedestrian and Bikeways and Goal 9 Parks, and how well it complies with the Tualatin Development Code, Chapter 11.650 Pedestrian, Bicycle, and Multi-Use Path Modal Plan and Chapter 72 Natural Resource Protection Overlay District.

Architectural Review Board Meeting. At the request of the applicant and with direction from the City Council, the Architectural Review Board (ARB) commented on the proposed Master Plan in an advisory meeting on June 19, 2013. ARB comments are summarized in Attachment 107 ARB Comment Summary & Minutes. The ARB expressed support for the great opportunities that redevelopment of this site will bring to Tualatin. The comments focused on the site as a gateway development and entrance to downtown, automobile access and connections, pedestrian and bicycle access, landscaping plazas and public space, architecture and Tualatin River integration.

Review Criteria

The criteria for approving the Master Plan are found in the CURD Plan Goals and Objectives. There are eleven (11) Goals and Objectives to consider, which consist of such items as transportation and pedestrian functions, building and landscape design, and utilities, among other considerations.

Staff reviewed the application with respect to each of the CURD Plan Goals and Objectives. Where Staff found the Master Plan proposal failed to meet a particular Goal and Objective, a condition or action to meet that Goal is proposed.

Generally, the Nyberg Rivers Master Plan as proposed in Attachment 102A-102D, Exhibit A meets the goals and objectives of the CURD Plan if the proposed conditions of approval are applied. The following is a summary of the analysis of the Master Plan as it relates to each CURD Plan Goal and Objective. Staff's complete analysis and findings, along with the recommended conditions, are contained in Attachment 104.

Goal 1 Commercial Development. *To encourage and facilitate commercial development in the Urban Renewal Area with an emphasis on establishing a visible and viable central business district that encourages community and business activity on weekdays, evenings and weekends.*

Analysis. The Nyberg Rivers Master Plan proposal meets Goal 1 with a condition about development of drive-up, drive-in or drive-thru services in the downtown area.

The proposed Nyberg Rivers Master Plan shows one new and one relocated drive-thru restaurant (replaced Wendy's Restaurant) facilities that will be in addition to the three bank drive-thrus on the site. Drive-thru restaurants are not conducive to pedestrian friendly developments, creating pedestrian crossing conflicts and auto-exclusive areas that discourage people from walking between buildings and connecting to public walkways. Too many drive-thru facilities in the downtown area is not supportive of Goal 1 and objectives to achieve a visible and viable central business district.

Staff recommends the Master Plan approval include a condition limiting the number of drive-thru facilities on the Nyberg Rivers site to no more than four and design any new or re-located drive-thru facilities so the service windows and service aisles are oriented away from public streets.

Proposed Conditions of Approval.

- a. Limit the number of drive-thru facilities on the Nyberg Rivers site to no more than four and design any new or re-located drive-thru facilities so the service windows and service aisles are oriented away from public streets.

Goal 2 Housing. *To encourage multi-family housing in the Urban Renewal Area as supportive of commercial development.*

Analysis. A commercial development can be supported by neighboring residential properties when the commercial development is attractive, safe and well-connected to public ways, service, and shopping opportunities. The proposed Master Plan shows no entrances or windows to the north of the buildings where the main residential properties are located. Further, the north area is where the proposed pedestrian path along the river is located. The proposal meets the intent of this Goal with a condition requiring attractive and pedestrian oriented features connecting to nearby residential areas.

Proposed Conditions of Approval.

- a. Site design and building design shall provide attractive and pedestrian-oriented features including accessways and pathways that will connect to existing and future residential development in the downtown area such as in the Tualatin Commons and specifically to the adjoining Heron's Landing Apartments property.

Goal 3 Industrial Development. *To promote new industrial development in the southwestern sub-area of the Urban Renewal Area which is compatible with existing development; and to encourage retention and expansion of existing industries in the northern and southwestern sub-areas of the Urban Renewal Area.*

Analysis. The Goal is not applicable to the proposed Nyberg Rivers Master Plan as the area is not designated for industrial use.

Goal 4 Civic Development. *To promote civic facilities, including community gathering spaces and other pedestrian amenities, a community center, library expansion and a City Hall in the Urban Renewal Area, which is supportive of other civic and private uses in the area.*

Analysis. The Master Plan includes the Tualatin River Greenway Trail as a shared use path to provide linkage between east side Tualatin residential, commercial, civic, and park uses, including the City Hall/Library Campus. The Master Plan also proposes a plaza and bicycle and pedestrian access. The Greenway Trail is addressed again under Goal 6

Pedestrian and Bikeways in 6.1 and under Goal 9 Park and Recreation System in 9.2.

Review of the Plans shows that there are conflicts and deficiencies associated with the proposed public plazas, outside sales areas, and public walkways and accessways and conditions are necessary to meet Goal 4. Proposed loading and delivery facilities and truck routes conflict with nearby public facilities.

With the improvements recommended under Goal 6 and Goal 9, the Tualatin River Greenway Trail elements of the Master Plan will meet Goal 4.

Proposed Conditions of Approval.

- a. Recreational equipment, apparel and sports outfitting sales are prohibited in areas identified as public gathering, multi-function open plaza and plaza seating with fire pit on Attachment 102D page 60, Building Frontage landscape plan.
- b. The proposed "outside sales areas" shall provide a minimum of 12 feet in clear, unobstructed width for public gathering spaces, accessways and walkways measured from the edge of an "outside sales area".
- c. A minimum of 12 feet in clear, unobstructed width for walkways or accessways through a plaza or along the building frontage between Building D1 on the west and southeast corner of Building 1040 on the east.
- d. Pedestrian linkages between the main Nyberg Rivers development and Tualatin civic and public spaces to the west across the Library plaza, the Tualatin Commons and downtown via the SW Seneca Street or other approaches.
- e. Remove the Truck Route designations from Street "A" and Seneca Street in order to eliminate impacts to the Library/City Hall Plaza, Shared Pathway, and other pedestrian crossings of these roads and drive aisles.

Goal 5 Traffic and Transportation: *To provide transportation access and circulation which is supportive of central area development.*

Analysis. Staff review and additional DKS & Associates review of the Traffic Impact Analysis (Attachment 105) determined that the development should be required to show the proposed Seneca Street extension and signal at Martinazzi Avenue are needed to serve the Nyberg Rivers Master Plan area.

ODOT reviewed the submitted information for their facilities (I-5 and Nyberg Street). Based on the analysis performed by ODOT, the proposed improvements mitigate the impact of the development on ODOT facilities. Final design may indicate the need for additional right-of-way. (Attachment 106)

Washington County also reviewed the information and they have provided a list of conditions and measures to mitigate impacts on Nyberg Street and Tualatin-Sherwood Road (please see attached comments from Washington County). Final design may indicate the need for additional right-of-way. (Attachment 106).

Allowing public access over the private drive aisles are supported by the submitted

Kittelson traffic study that shows public access will function adequately and the proposed cross-sections for the locations of the public access have "street-like" qualities. Public access over the "street-like" cross sections from the south end of Street "A" to the east end of SW Seneca Street to SW Nyberg Road and revised cross sections for private streets as detailed in the Attachment 104 Analysis and Findings are necessary to meet Goal 5. To achieve access and circulation supportive of the downtown area, recorded private access from all remaining lots to public right-of-way are necessary.

Proposed Conditions of Approval.

a. The proposed Seneca Street extension to the Nyberg Rivers site with a signal at SW Martinazzi Avenue are constructed to the standards of a Minor Collector Street.

b. The following improvements are necessary for this development:

- A westbound right turn lane on SW Nyberg Road.
- Two southbound left turn lanes and a shared through/right turn lane from the site's access onto SW Nyberg Road.
- Two inbound receiving lanes and
- The associated signal improvements at the main entrance.

c. Revised Plans for the

Attachment 102D Exhibit B: Cross-section A-A:

- A 4 to 7-foot planter strip on the east side with curb, streetlights, and trees
- A 4-foot planter on the west side with curb, streetlights adjacent to the travel lanes, and groundcover and shrubs with a 14-foot shared path with tree wells
- Three 12-foot southbound travel lanes
- Two northbound 12-foot travel lanes
- A center median consisting of an 18-inch concrete median, with striping on both sides for a total of 2.5-feet

Attachment 102D Exhibit C: Cross-section B-B:

- An 12-foot pedestrian walkway on the north side with tree wells
- Two 13-foot travel lanes; 12 foot travel lanes are acceptable.
- A 6-foot planter on the south side
- A 5-foot sidewalk on the south side

Attachment 102D Exhibit D: Cross-section C-C:

- A 10-foot wide pedestrian walkway on the east side with tree wells
- 17.5-foot angled parking on both sides
- Two 14-foot travel lanes
- A 4-foot sloped landscape area on the west side
- A 12-foot multi-use path on the west side

Attachment 102D Exhibit E: Street "A": Cross section D-D

- A 12-foot multi-use path on the west side
- A 4-foot planter strip with curb, streetlights, and trees
- Two 12-foot travel lanes
- A 6-foot bike lane on the east side
- A 5-foot sidewalk on the east side
- The pork chop at the intersection of Boones Ferry Road will be mountable for emergency vehicles

City Parking Lot/Heron's Landing/Access to Street "A" and intersection with the greenway:

- The driveway/access shown 40-feet wide

- The multi-use path crossing located south of the accessway. The crossing will include striping and bump-outs
- The Heron's Landing Apartment access easement opposite the City staff parking lot access.
- A crosswalk on Street "A" adjacent to SW Boones Ferry Road

Attachment 102D Exhibit G: Nyberg Street between the entrance of the site and Martinazzi Avenue: Cross section F-F

- A 4-6-foot planter strip with trees. This planter does not include curbs and streetlights, which are placed on the curb-tight sidewalk.
- A 5-6-foot curb-tight sidewalk on the north side of Nyberg Road
- A 6-foot bike lane
- Two 11-foot westbound travel lanes
- The north-south crosswalk across Nyberg Street will have a dedicated pedestrian/bicyclist-activated sequence

Attachment 102D Exhibit H: Nyberg Street between the entrance of the site and I-5: Cross section G-G

- A 12-foot sidewalk on the north side of Nyberg Road
- A 4-foot planter strip with curb, streetlights, and trees
- A 15-foot westbound right-turn lane
- A 5-foot bike lane
- No proposed changes to the existing west and east-bound turn lanes
- A two foot landscape strip prior to a hand rail on top of a retaining wall, then a water quality pond.

Seneca Street and the signal at SW Martinazzi Avenue

- Two 12-foot travel lanes
- One 14-foot center turn lane
- Two 6-foot bike lanes
- Two 8-foot parking strips
- Two 6-foot planter strips with curbs, streetlights, and street trees
- Two 6-foot sidewalks

Goal 6 Pedestrian and Bikeways: *To develop a pedestrian/bicycle system linking the Urban Renewal Area to residential areas, parks, natural areas, and to link the business district on the south side of SW Boones Ferry Road to the future business district on the north side of SW Boones Ferry Road.*

Analysis. The Master Plan Pedestrian and Bike Plans show the Tualatin River Greenway Trail and bicycle and pedestrian access connections and facilities (Attachment 102D, Exhibit L). The Greenway Trail is addressed again under Goal 4-Civic Development and under Goal 9-Park and Recreation System. Staff identifies conflicts and deficiencies with the proposed Greenway Trail, North/South Bikeway, Shared Pathways to the Tualatin Library/City Hall, to SW Boones Ferry Road, SW Nyberg Street and East Tualatin. The proposed Master Plan will meet Goal 6 with conditions requiring adequate facility dimensions, design features, public access, and connections to off-site facilities.

Proposed Conditions of Approval.

- All shared pathways shall be open to the public.
- The Master Plan shall provide a 12' sidewalk with a curbside planter on the north side of Nyberg Street between the Nyberg Rivers access and the SW Nyberg Street overpass at I-5.

c. New or relocated buildings on the Nyberg Rivers site shall have bicycle parking facilities.

Goal 7 Transit: *To support the development of the metropolitan transportation system (Tri-Met) in order to provide alternative transportation modes for the residential and employment population of the Urban Renewal Area.*

Analysis. TriMet service is located near to the Nyberg Rivers site on SW Martinazzi (a stop at the City Library) and on SW Boones Ferry Road extending from the WES Commuter Rail station further west to the Tualatin Park & Ride located at I-5 Exit 290 to the north. The proposed “Street A” extension from the Nyberg Rivers site to SW Boones Ferry Road will be near an existing TriMet bus stop on SW Boones Ferry Road near the Tualatin River Bridge. TriMet will have an opportunity to evaluate the impact of the Nyberg Rivers development on the transit system at the Architectural Review step of the redevelopment project. Goal 7 is not applicable to the Master Plan step of the Nyberg Rivers development.

Proposed Conditions of Approval. Does not apply to the Master Plan step. No conditions recommended.

Goal 8 Utilities: *To assist in providing public utilities in the Urban Renewal Area as needed to facilitate growth and aesthetic quality.*

Analysis. The proposal will direct access to public utility services after consolidation of lots and relocation of public lines. Public and private stormwater is proposed to be treated by mechanical filters which is acceptable. The proposal meets the intent of Goal 8.

Proposed Conditions of Approval. Goal 8 is met. No conditions recommended.

Goal 9 Parks: *To provide a high-quality park and recreation system to offset the environmental effect of large areas of commercial and industrial development.*

Analysis. The proposed Nyberg Rivers Master Plan preserves the natural value of the Tualatin River as a scenic, recreational, and open space asset to a greater extent than required for the Tualatin River Greenway. The designated Natural Area is protected by an easement with Clean Water Services that ensures the preservation and conservation goals of the Tualatin River Greenway.

The Master Plan shows proposed Tualatin River Greenway Trail, North/South Bikeway Trail, Other Pedestrian and Bikeway Facilities, Connectivity and Linkages. The analysis in Goal 6 determines the proposed facilities need to be designed to acceptable standards and open to the public.

Proposed Conditions of Approval. The proposal meets the intent of this Goal with conditions a-c listed in Goal 6, above.

Goal 10 Flood Protection: *To promote the public health, safety, and general welfare, and to minimize public and private losses due to flood conditions.*

Analysis. No proposed private structures or redeveloped structures are within areas of the

100-year floodplain or floodway. Nyberg Rivers Master Plan proposed street “A” and most of the existing Seneca Street are within the floodplain. New street “A” and any modification to Seneca Street should be elevated at least 1-foot above the 100-year floodplain. Cut of grade equivalent to any fill to elevate any public street should be performed in the immediate vicinity in order to not increase the 100-year floodplain.

Proposed Conditions of Approval The proposal meets the intent of this Goal with a condition requiring:

- a. No increase in the 100-Year Floodplain associated with improvements to public "Street A" and SW Seneca Street.

Goal 11 Design Considerations: *To create an atmosphere in the Urban Renewal Area which is aesthetically pleasing in order to promote the desirability of investment and occupancy in properties.*

Analysis. The design considerations associated with the Nyberg Rivers Master Plan and development on the site are identified as: Design the development with a relationship to the Tualatin River, to the downtown areas of Tualatin including the Tualatin Commons, and as a primary Gateway to Tualatin at the Interstate I-5/Nyberg Street interchange (See Attachment 101-Vicinity Map). Public open space and gathering space available to general public use are important. To achieve these considerations, the center's site and building design elements including building locations, building orientation of entrances and windows, building architecture, public gathering spaces, outside commercial activities, bicycle and pedestrian facilities, landscaping and parking areas must be revised or improved.

To meet Goal 11, the site and buildings must have entrances, windows and activities oriented to the Tualatin River. Adequately located and sized areas for public use must be provided. The building architecture must include additional features on each elevation of the buildings consistent with the character of a downtown and as a primary gateway to the city. Retaining existing trees on the site and designing the site's landscaping to include large conifer trees characteristic of Tualatin is necessary. Bicycle and pedestrian connections must be designed to be free of conflicts with on-site vehicle traffic and commercial activities. Parking areas must be designed with trees and landscape planters that will provide relief from the pavement areas. Staff is requesting Council direction on the adequacy of the proposed parking lot "diamonds" as parking lot landscaping.

The applicant proposes a “Conceptual Design Package” (Attachment 102D, Exhibit R) showing conceptual freestanding signage on the Nyberg Rivers site. It is unclear from the application materials if the proposed Nyberg Rivers sign concepts will meet the Sign Regulations and Non-conforming Sign requirements. If the Nyberg Rivers project seeks signage that is not allowed under the Sign Regulations in TDC Chapter 38, the applicant would need to obtain a sign variance or an amendment to the Tualatin Development Code changing the sign standards under a separate process such as an amendment or variance to the Sign Regulations and not in the Master Plan process.

Proposed Conditions of Approval. The proposal meets the intent of Goal 11 with conditions requiring:

- a. Building 1040 shall have a public entrance and windows on the north sides or at the northeast corner of the building.

- b. There shall be additional windows and architectural features that break up the building mass and add architectural interest on each of the four sides of Buildings 1040, G-100, H-100, J-100 and N-100.
- c. Building 1040 shall have variations in building height, additional gabled roof feature, canopy feature, entry feature, dimensional wall feature such as columns or pilaster and projected entries, show larger window and entry areas and show diversity in exterior wall design and material on all four sides of the building.
- d. The loading and service facilities for the existing Michaels (Building D2) and new Buildings 1005, 1010 and 1040 shall provide adequate visual and noise buffering for the benefit of nearby public areas and residential areas.
- e. If the Council determines that "diamond" style planters in the parking areas are not acceptable:
- then interior parking lot landscape islands that separate groups of parking stalls shall extend for the length of parking stalls separated by the required planters.
- Or, if the Council determines the "diamond" style planters in the parking areas are acceptable:
- the applicant may utilize the diamond planters as proposed in Attachment 102A and 102D to meet the parking lot landscaping island standards of TDC Chapter 73.360.
- f. When oversized vehicle parking stalls occupy or replace standard parking stalls proposed in the Master Plan, the total number of parking stalls and the dimensions shall be adjusted accordingly to reflect the revision.
- g. Provide an additional 15 Douglas Fir, Western Red Cedar, or other tall-maturing conifer tree plantings in the landscape plan for location on the site's eastern frontage along I-5.
- h. A tree maintenance plan for the Nyberg Rivers site and a tree preservation plan that establishes protection of trees on the former Nyberg House site (tax lot 2502). Where tree preservation is not possible, provide 3" caliper or 10-12 foot replacement tree plantings of a similar character in the vicinity of where trees were removed on Tax Lot 2502.
- i. The applicant's proposed Nyberg Rivers Sign Program is not in the purview of the Master Plan and is not approved.

Next Steps

1. A public hearing is also scheduled for July 22, 2013 to review a Conditional Use Permit to allow retail sales on the Commercial Office portion of the Nyberg Rivers site and to allow outdoor sales on the Central Commercial portion of the site.
2. If the Master Plan is approved, the applicant can submit an application for an Architectural Review that will be reviewed in a public hearing before the Architectural Review Board.

3. Simultaneously, the applicant can submit for a Public Facilities decision administered by the City Engineer.

4. The applicant intends to start construction this fall with a goal for grand opening in Fall of 2014.

OUTCOMES OF DECISION:

Approval of the Master Plan (MP-13-01) request will result in the following:

1. The Nyberg Rivers Master Plan meets the requirement of the Central Urban Renewal District Plan for Master Plan approval and allows the developer of the proposed Nyberg Rivers Shopping Center to submit applications for Architectural Review of the project.
2. The project will be subject to the Master Plan approvals and conditions of approval adopted by the Council. The approvals and requirements of the Master Plan decision will be addressed in the project's Architectural Review.

Denial of the Master Plan (MP-13-01) request will result in the following:

1. As required in the CURD Plan, the applicant will be unable to obtain Architectural Review approval of the proposed Nyberg Rivers project until a Master Plan is approved by the Council.

ALTERNATIVES TO RECOMMENDATION:

The alternatives to the staff recommendation for the Council are:

1. Approve the proposed Nyberg Rivers Master Plan (MP) with conditions that the Council deems necessary to satisfy the Goals and Objectives of the Central Urban Renewal District Plan (CURD Plan).
2. Deny the request for the proposed MP with findings that state which CURD Plan Goals and Objectives the applicant fails to meet.
3. Continue the discussion of the proposed MP and return to the matter at a later date.

FINANCIAL IMPLICATIONS:

The Fiscal Year 2013/14 budget allocated revenue to process current planning applications, and the applicant submitted payment of \$325.00 per the City of Tualatin Fee Schedule to process the application.

-
- Attachments:**
- 101 - Nyberg Rivers Vicinity Map
 - 102A - Nyberg Rivers Master Plan- Proposed Site Plan
 - 102B - Nyberg Rivers Master Plan-Application Binder
 - 102C - Nyberg Rivers Master Plan - Presentation Document
 - 102D - Nyberg Rivers Master Plan - Addendum 1
 - 103 - CURD Goals & Objectives-Master Plan
 - 104 -Analysis & Findings with Conditions of Approval
 - 105 - DKS Analysis-Combined Report

106 - Agency Comments

107 - Public Comments-ARB & TPARK Advisory Comments

108- Presentation



Nyberg Rivers Vicinity Map
Attachment 102

PROJECT SUMMARY

MASTER PLAN AREA:	44.15 ACRES
FUTURE DEVELOPMENT AREAS: (by others)	12.24 ACRES
PRIMARY DEVELOPMENT AREA:	
GROSS AREA:	31.91 ACRES
NATURAL AREA:	5.33 ACRES
NET AREA:	26.58 ACRES
REQUIRED LANDSCAPE AREA: ACRES	15% / 4.78
LANDSCAPE AREA PROPOSED:	10.34 ACRES
FLOOR AREA RATIO:	0.265
TOTAL PERMISSIBLE BUILDING AREA:	307,000 SF

BUILDING	AREA
BLDG 1005	33,562 SF
BLDG 1010	21,750 SF
BLDG 1030	2,900 SF
BLDG 1040	110,093 SF
BLDG A	12,500 SF
BLDG B	5,850 SF
BLDG C	3,950 SF
BLDG D	32,459 SF
BLDG E	3,285 SF
BLDG F	5,500 SF
BLDG G-100	6,500 SF
BLDG H-100	4,526 SF
BLDG J-100	5,797 SF
BLDG N-100	45,000 SF
TOTAL:	293,672 SF

ADDITIONAL POTENTIAL BUILDING AREA: 13,328 SF

TOTAL PROVIDED STALLS:	1,320 stalls
PARKING RATIO:	4.49/1,000 SF
PARKING STALL DIMENSIONS:	STANDARD 9-ft X 19-ft COMPACT 7.7-ft X 16-ft

- Notes:
- "Site Area" includes only the areas of Tualatin Urban Renewal Blocks that are subject of this development proposal. Other phases of the Master Plan may be developed by others.
 - Required Landscaping based on Gross Site Area
 - Building areas listed in table may differ from actual footprint size to allow for interior walls and architectural elements.
 - For design detail of the handscape and landscaping along shops of buildings D.2, 1005, 1010, 1030 and 1040, reference Exhibit Q-1 Building Frontage Landscape Plan.





City of Tualatin

www.ci.tualatin.or.us

**"NECESSARY PARTIES"
MARKED BELOW**

NOTICE OF APPLICATION SUBMITTAL

- ANNEXATION
- ARCHITECTURAL REVIEW
- CONDITIONAL USE PERMIT
- PLAN MAP AMENDMENT
- PLAN TEXT AMENDMENT
- OTHER: MASTER PLAN

CASE/FILE: MP-13-01

(Community Development Dept.: Planning Division)

PROPOSAL	To Master Plan the proposed Nyberg Rivers retail development on the former KMart site and associated properties. An approved Master Plan is required prior to redevelopment of this site. The proposed redevelopment Master Plan includes demolition of three existing buildings, construction of seven (7) buildings, access and public facilities improvements, parking, pedestrian, bicycle, and landscaping improvements. Following Master Plan review by the City Council, Architectural Review is required.
-----------------	---

<input type="checkbox"/> n/a	Street Address	7455-7925 SW Nyberg Ave
	Tax Map and Lot No(s)	2S1 24 A 1601,1602, 1900, 2502, 2506, 2507,2508, 2700, 2S1 24B 2000, 2001,2100
	Planning District	Central Commercial (CC) Office Commercial (CO)
	Related Applications	CUP-13-04 Conditional Use Permit for Retail use in CO and Outdoor Storage in CC Planning Districts

DATES	Receipt of application	4/23/2013	CONTACT	Name: Will Harper
	Notice of application submittal	4/25/2013		Title: Senior Planner
	Project Status / Development Review meeting	5/23/2013		E-mail: wharper@ci.tualatin.or.us
	Comments due for staff report	5/17/2013		Phone: 503-691-3027
	Public meeting: <input type="checkbox"/> ARB <input type="checkbox"/> TPC <input checked="" type="checkbox"/> n/a			Notes: Council Public Hearing Date to be determined
	City Council (CC) <input type="checkbox"/> n/a	TBD		

City Staff

- City Manager
- Building Official
- Chief of Police
- City Attorney
- City Engineer
- Community Dev. Director
- Community Services Director
- Economic Dev. Manager
- Engineering Associate
- Finance Director
- GIS technician(s)
- IS Manager
- Operations Director
- Parks and Recreation Coordinator
- Planning Manager
- Street/Sewer Supervisor
- Water Supervisor

Neighboring Cities

- Durham
- King City Planning Commission
- Lake Oswego
- Rivergrove PC
- Sherwood Planning Dept.

- Tigard Community Dev. Dept.
- Wilsonville Planning Div.

Counties

- Clackamas County Dept. of Transportation and Dev.
- Washington County Dept. of Land Use and Transportation

Regional Government

- Metro

School Districts

- Lake Oswego School Dist. 7J
- Sherwood SD 88J
- Tigard-Tualatin SD 23J (TTSD)
- West Linn-Wilsonville SD 3J

State Agencies

- Oregon Dept. of Aviation
- Oregon Dept. of Land Conservation and Development (DLCD) (via proprietary notice)
- Oregon Dept. of State Lands: Wetlands Program
- Oregon Dept. of Transportation (ODOT) Region 1
- ODOT Maintenance Dist. 2A
- ODOT Rail Div.

Utilities

- Allied Waste Services
- Clean Water Services (CWS)
- Comcast [cable]
- Frontier Communications[phone]
- Northwest Natural [gas]
- Portland General Electric (PGE)
- TriMet
- Tualatin Valley Fire & Rescue (TVF&R)
- United States Postal Service (USPS) (Washington; 18850 SW Teton Ave)
- USPS (Clackamas)
- Washington County Consolidated Communications Agency (WCCCA)

Additional Parties

- Tualatin Citizen Involvement Organization (CIO)
- DKS



Perkowitz + Ruth
ARCHITECTS



NYBERG RIVERS

Tualatin, Oregon

An Application For:
Master Plan Review
Conditional Use Permit
Submitted: April 8, 2013

Applicant:
Centercal Properties, LLC
7455 SW Bridgeport Road, Suite 205
Tigard, OR 97224
Phone: (503) 968-8940
Contact: Hank Murphy

Prepared by:
Cardno WRG
5415 SW Westgate Drive, Suite 100
Portland, Oregon 97221
Phone: 503-419-2500
Fax: 503-419-2600

21198310



An Application For:
Master Plan Review
Conditional Use Permit
Submitted April 8, 2013

NYBERG RIVERS
Tualatin, Oregon



Nyberg Rivers

Tualatin, Oregon

An Application For:
Master Plan Review
Conditional Use Permit

Submitted April 8, 2013
Re-submitted April 23, 2013

Applicant:
Centercal Properties, LLC
7455 SW Bridgeport Road, Suite 205
Tigard, OR 97224
Phone: (503) 968-8940
Contact: Hank Murphy

Prepared by:
Cardno WRG
5415 SW Westgate Drive, Suite 100
Portland, Oregon 97221
Phone: 503-419-2500
Fax: 503-419-2600

21198310

PAGE INTENTIONALLY LEFT BLANK

TABLE OF CONTENTS

I. INTRODUCTION..... 5

GENERAL INFORMATION 5

SUMMARY OF PROPOSAL 6

SURROUNDING USES..... 8

II. CITY OF TUALATIN CENTRAL URBAN RENEWAL PLAN (2009) 9

1. GOALS AND OBJECTIVES OF THE URBAN RENEWAL PLAN 9

2. RELATIONSHIP TO LOCAL OBJECTIVES17

III. TUALATIN MUNICIPAL CODE (TMC) 25

CHAPTER 03-05: SOIL EROSION, SURFACE WATER MANAGEMENT, WATER QUALITY FACILITIES,
AND BUILDING AND SEWERS.....25

IV. TUALATIN DEVELOPMENT CODE (TDC) 35

TDC 6: COMMERCIAL PLANNING DISTRICTS35

TDC 9: PLAN MAP39

TDC 11: TRANSPORTATION41

TDC 30: TUALATIN URBAN RENEWAL PLAN.....60

TDC 32: CONDITIONAL USES65

TDC 43: HIGH DENSITY RESIDENTIAL PLANNING DISTRICT (RH)72

TDC 50: OFFICE COMMERCIAL PLANNING DISTRICT (CO)72

TDC 53: CENTRAL COMMERCIAL PLANNING DISTRICT (CC).....75

TDC 73: COMMUNITY DESIGN STANDARDS80

TDC 74: PUBLIC IMPROVEMENT REQUIREMENTS..... 112

TDC CHAPTER 75: ACCESS MANAGEMENT ON ARTERIAL STREETS 130

V. CONCLUSION 136

EXHIBITS

- Exhibit A Master Plan Document
- Exhibit B City Applications
- Exhibit C Site Plan Set
- Exhibit D Zoning Map & City Plan Exhibits
- Exhibit E Tax Map
- Exhibit F Transportation Impact Analysis
- Exhibit G Clean Water Services Documentation
- Exhibit H Neighborhood/Developer's Meeting Material

I. INTRODUCTION

GENERAL INFORMATION

Applicant: Centercal Properties, LLC
7455 SW Bridgeport Road, Suite 205
Tigard, Oregon 97224
Phone: (503) 968-8940
Contact: Hank Murphy

Applicant's Representative Cardno WRG
5415 SW Westgate Drive; Suite 100
Portland, Oregon 97221
(503) 419-2500 phone
(503) 419-2600 fax
Contact: Michael Cerbone, AICP
michael.cerbone@cardno.com

Tax Lot Information:	Map	Tax Lots
	2S124A & 2S124B	1500, 1601, 1602, 1900, 2000, 2001, 2100, 2502, 2506, 2507, 2508, 2700

Location: City of Tualatin, Oregon
Generally bounded by SW Nyberg Rd to the south,
Martinazzi Ave to the west, Interstate 5 to the east,
and the Tualatin River to the north.

Current Zoning Districts: Office Commercial (CO)
Central Commercial (CC)
High-Density Residential (HR)

Project Site Area: +/- 31.91 acres

SUMMARY OF PROPOSAL

THE MASTER PLAN

The Nyberg Rivers Master Plan area requires approval of a master plan prior to development of the site. Specific guidance for what constitutes a “master plan” is provided for within the City of Tualatin *Central Urban Renewal Plan - October 2009*:

“Prior to approval of applications for development projects within Blocks 1, 2, 3, 4, 5, 13, 25, 26, 27, 31, 32, and 33, applicants will be required to submit and gain City approval of a master plan governing development within the Block(s). Such master plan shall contain sufficient information, as determined by the City, to ensure that development meets the objectives of the Plan. Master plans may include, but are not limited to, treatment of such issues as access, transportation, sewer, water, storm drainage, internal circulation, building location, building design and materials, parking, landscaping and pedestrian facilities.

Master plans for Blocks 1, 2, 3, 4, 5, 13, 25, 26, 27, 31, 32, 33, as well as subsequent modifications to those plans, must be approved by the City Council at a public hearing. The public hearing shall be called and conducted in the manner provided for in Section 1.031 of the Tualatin Development Code. In approving a master plan, the City Council may attach conditions that it finds necessary to achieve the objectives of the Urban Renewal Plan.”

The Central Urban Renewal Plan (heretofore listed as “The Plan”) was originally adopted on January 27, 1975 and has undergone several amendments to reflect the City of Tualatin’s current vision for the overall urban renewal area, as well as specific blocks designated within the subarea. An accompanying report to The Plan outlines the goals and objectives, as well as an outline of the project activities undertaken through The Plan. These project activities are public improvements under the following categories:

- Flood Control—minimizing flood risk within The Plan area
- Roads and Streets—identifying specific streets and interchanges needing infrastructure improvements and capital funding.
- Utilities—improvements needed in sanitary sewer, storm sewer, water supply, and electricity systems. Specific project activities are summarized.
- Parking Facilities—establishment of the Core Area Parking District (CAPD) in 1979, as well as impact fees on new construction to provide for parking lot development within the parking district.
- Pedestrian Facilities—improvement of pedestrian circulation within the URA through the construction of sidewalks, improvements to the triangular park site, and the development of design guidelines for private pedestrian walkways and street furniture.
- Civic Facilities—includes pedestrian oriented facilities, major features of Tualatin Commons (water feature and landmark), site acquisition for police facility, library expansion and participating in design discussion for a community building.

- Transit Facilities—assisting Tri-Met in locating park-and-ride facilities and encouraging private development to integrate transit provisions.

The Plan also outlines land uses within the renewal area, which are governed by the Planning District Standards outlined in the Tualatin Development Code. The Planning District Designations applicable to this master plan application include the Central Commercial (CC), Office Commercial (CO), and High Density Residential (HR) designations. A discussion of permitted uses as well as additional considerations for Blocks 1, 2, 3, 4, and 5 is addressed in Section II of this project narrative.

The Nyberg Rivers Master Plan represents a comprehensive and collaborative effort to create a vibrant center that provides a seamless extension of the Tualatin City Center. The primary commercial tenants will work to attract regional visitors to the City core in a mix of uses; creating vibrant and active City Center. In addition, this project will provide transportation, pedestrian and bicycle amenities and linkages to the regional framework serving residents and visitors to the site. The Nyberg Rivers Master Plan will play an important role in establishing the Tualatin City Center as a regional draw for residents, visitors, businesses, and critical public facilities.

The Nyberg Rivers Master Plan is a multi-tenant shopping center redevelopment project. The Site Plan, attached as Exhibit C, illustrates the build-out plan for the project. The master plan and the Development Plan, attached as Exhibit A, is focused on the areas designated as the Primary Development Area, whereas, the residual areas are designated as Future Development Area(s). The Primary Development Area is controlled by CenterCal Properties, LLC (the developer) and detailed project planning has occurred on these portions of the master plan. The Future Development Area(s) are anticipated to be pursued and completed by others. The Development Plan focuses project statistics and planning on the Primary Development Area. The shopping center has been carefully planned so that development within the Primary Development Area does not preclude and in fact facilitates later development in the Future Development Areas.

The balance of this project narrative addresses each of the applicable approval criteria for a master plan and demonstrates that the proposed development conforms with each criterion.

CONDITIONAL USE PERMIT

There is one conditional use approval requested under this application. As a supplement to the associated Master Plan sections, those uses identified as conditional use are addressed in this narrative. Based on conversation with the City of Tualatin and comments received during the Pre-Application conference held on March 7, 2013, a portion of the proposed retail store located in Building 1040 is subject to CUP review and approval, as the site straddles the CC and CO planning districts. The portion of building in the CC District is permitted outright and the portion of the building located in the CU District, as well as the outdoor storage and sales, is subject to the approval criteria of Chapter 32. Under 50.030(2), uses in the CC District are allowed as conditional uses in the CO District. Further, under 53.050 (5), outdoor storage and sales are permitted in the CC District as a conditional use. Accordingly, the conditional use narrative specifically addresses the [square feet of Building 1040 located in the CO zone and the outdoor storage and sales located in the CC zone. All other uses on the site are permitted uses and do not require a conditional use permit.

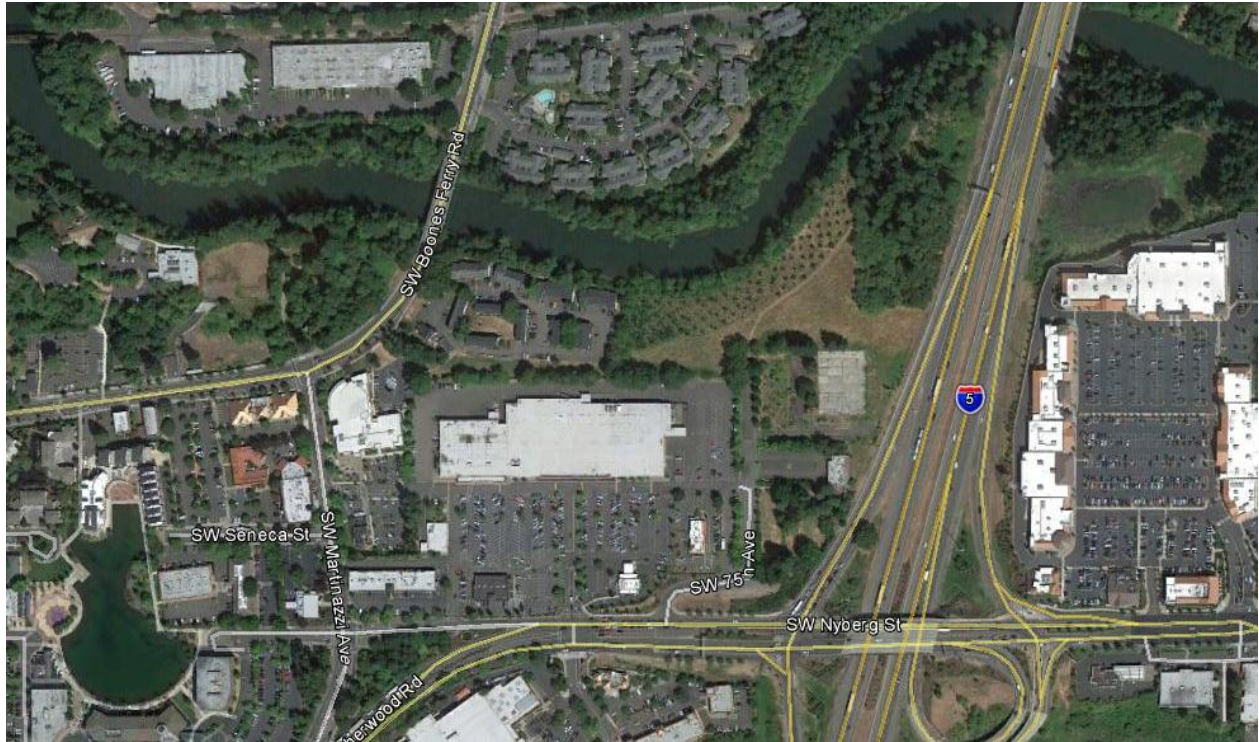

SURROUNDING USES

Table A: SURROUNDING LAND USE

<i>Location</i>	<i>Zoning Designation</i>	<i>Land Use</i>
North	High Density Residential (RH) General Commercial (CG)	Tualatin River & Heron's Landing Apartments
South	Central Commercial (CC)	SW Nyberg Street/ Fred Meyer
East	General Commercial (CG)	Interstate 5
West	General Commercial (CG)	SW Martinazzi Avenue/ Tualatin Central Downtown

II. CITY OF TUALATIN CENTRAL URBAN RENEWAL PLAN (2009)

1. GOALS AND OBJECTIVES OF THE URBAN RENEWAL PLAN

THE OVERALL GOAL OF THE PLAN IS:

To strengthen the social and economic development of central Tualatin by stabilizing and improving property values, eliminating existing blight, and preventing future blight; and to encourage and facilitate land uses, private and public, that result in activity during all business hours, evenings, nights, and weekends; and to encourage indoor and outdoor uses.

LAND USE

Objective: Implement the Tualatin Commons Redevelopment Project and Central Design District Enhancement Project to provide an appropriate environment which encourages private development within the Project area' and surrounding properties that support the overall goal. A major water feature may be included in the Tualatin Commons Redevelopment Project. Both projects will be oriented to pedestrians with connections to the Tualatin Community Park and to other public and private developments in the town center area.

The projects will be implemented as a series of public/private partnerships. The role of the Commission includes acquiring and packaging development sites; conveying, by sale or lease, portions of the sites to private developers; and contributing towards construction of public facilities and improvements. These public facilities may include but are not limited to a water feature, community facilities, pedestrian facilities, streetscape enhancements, art and parking facilities. Development of all commercial and residential space will be a private sector responsibility.

Response: The Nyberg Rivers Master Plan represents a private sector commercial redevelopment project that will transform an existing and underutilized shopping center into a vibrant economic asset for the City. The existing shopping center has been anchored by a now vacant K-Mart and includes an assortment of other supporting retail uses such as drive-thru banks, fast-food restaurants, and small to medium miscellaneous retailers.

In an effort to enhance and reinvigorate the existing shopping center, CenterCal is proposing to redevelop the center as shown on Exhibit C. The full redevelopment vision will include removal of the vacant but existing 96,799 square foot former K-Mart building and McBale property as well as the addition of a new mix of upgraded tenants including a large retailer and an assortment of small and medium-sized retail/restaurant uses. The redevelopment will bring a total of 245,456 SF of new leasable commercial space to the center, increasing the economic and social vibrancy of the center.

This proposal and the City's review and approval of this application will "encourage private development within the Project area and surrounding properties" as anticipated by the City under this objective. Certainly the redevelopment this center will result in increased business activities "during all business hours, evenings, nights and weekends" and will encourage indoor and

outdoor uses through a well-designed landscaped and plaza plan as well as active outdoor retail sales and storage uses.

Development of all commercial space under this proposal is a private sector responsibility. The development also proposes to improve and build several public facilities such as:

- A new roadway connection to SW Boones Ferry Road (shown as "Street A" in Figure 2) that includes sidewalks.
- An enhanced site-access driveway to SW Nyberg Road that will better accommodate vehicular queuing and demand.
- A potential future (assuming the City desires to move forward) new site-access connection to SW Martinazzi Avenue that aligns across from SW Seneca Street. This connection would be the Seneca Street extension envisioned in the Town Center Plan. Prior to the City making a decision on any new SW Street Seneca alignment, the redevelopment site plan preserves this connection opportunity in the present or future.
- The preservation of east-west and north-south travel ways that will provide vehicular and pedestrian access between Street A, the Seneca Street alignment/extension, and enhanced access to SW Nyberg Road.
- New sidewalks along the enhanced site-access driveway to SW Nyberg Road that provide pedestrian connections to the integrated site circulation network.
- New bikeway connections along the perimeter of the site.
- The existing SW 75th Avenue site-access driveway to SW Nyberg Road should be closed in order to minimize turning movement conflicts, allow for the construction of a westbound right-turn lane at the SW Nyberg Road/signalized site driveway, and improve the interchange access spacing conditions along SW Nyberg Road.

Together, the public infrastructure improvements and redevelopment of an underutilized commercial property with commercial uses are highly consistent with the overall goals and objectives of the Central Urban Renewal Plan.

GOAL 1: COMMERCIAL DEVELOPMENT

To encourage and facilitate commercial development in the Urban Renewal Area with an emphasis on establishing a visible and viable central business district that encourages community and business activity on weekdays, evenings and weekends.

Objectives (only applicable objectives listed):

- c. **Encourage the development of existing Central Commercial designated land before re-designating other land within the Urban Renewal Area as Central Commercial.**
- d. **Support Central Commercial designated land for development by assisting in the marketing and promotion of central Tualatin as a place to visit, shop, and conduct business.**

Response: The Nyberg Rivers Master Plan is located within an existing Central Commercial designated area. Objective C encourages the full utilization and development of this Central Commercial land before re-designating other land Central Commercial. Today, this center is underutilized. The Nyberg Rivers Master Plan will add over 245,000 square feet of net leasable space to a center that is currently underutilized in form and function and partially vacant. Objective D seems to be directed at the City and encourages the City to support Central Commercial land by promoting central Tualatin as a place to visit, shop and conduct business.

The City's assistance with and review of this application certainly supports the ultimate development of the site with Central Commercial uses and will further attract users to central Tualatin upon redevelopment of the center.

The redevelopment of this center will make better use of this existing land with a development that is more dense and connected to the existing City Center. The site plan and associated tenant mix allowed through this application will create a regional draw that will ultimately help the City with drawing visitors to the City Center.

IMPROVED TRAFFIC AND TRANSPORTATION

GOAL 5: TRANSPORTATION

To provide transportation access and circulation which is supportive of central area development.

Objectives (only applicable objectives listed):

- a. **Assist in and encourage opportunities to share parking between compatible developments. Such opportunities may include providing public parking for shared use for public and private entities in the Tualatin Commons Redevelopment Project Area and Central Design District Enhancement Project Area.**
- b. **Support the implementation of transportation improvements described in the Transportation Element of the Tualatin Community Plan and Transportation System Plan.**

Response: The Nyberg Rivers Master Plan will provide transportation access and circulation which is supportive of Central Area development. The off-street parking provided throughout the redevelopment site will operate as shared use parking and will

meet the needs of the tenants, while also conforming to the Tualatin Development Code parking minimums consistent with the subject land use districts.

The applicant has proposed a multi-modal site access and circulation plan. As shown on the Master Plan, Exhibit C, pedestrian and bicycle accessways are provided throughout the site that ties in to the existing regional framework. The Nyberg Rivers Master Plan—Pedestrian Bicycle Plan details this pedestrian and bicycle network. Connecting the on-site and off-site pedestrian and bicycle networks will allow safe, convenient and multi-modal access to the site for residents and visitors.

Vehicle access to the site is preserved and enhanced through several improvements identified in more detail within the TIA. In short, under the redevelopment plan, the existing 75th Avenue connection to SW Nyberg Road will be closed to allow for improved access management along SW Nyberg Road. The existing signalized access on SW Nyberg Road that currently serves the shopping center and the adjacent Fred Meyer site will remain. However, a few changes are proposed in order to better accommodate the redevelopment: (1) the westbound right-turn lane will be developed on SW Nyberg Road to enhance access to the site and minimize vehicle queuing on SW Nyberg Road; (2) the existing site driveway is proposed to be widened as shown in the proposed site plan to accommodate increased site traffic. This widening will include dual southbound left-turn lanes, a shared through/right-turn lane, and a single in-bound receiving lane. A raised median will be constructed in the driveway throat to control on-site turning maneuvers and manage vehicle queues within the driveway throat; (3) the north and south approach signal phasing is proposed to be modified from permissive left-turn phasing to split phasing.

With these improvements, all of the study intersections, site access points, and internal site intersections, except for the SW Martinazzi Avenue/SW Sagert Road and SW 65th Avenue/SW Sagert Road intersections (discussed below), are forecast to operate with acceptable operating standards during the weekday p.m. and Saturday midday peak hours.

The project will have an insignificant impact at either the SW Martinazzi Avenue/SW Sagert Road or the SW 65th Avenue/SW Sagert Road intersections (the project will result in a less than 1.5 percent increase in traffic at either intersection).

The TIA demonstrates that the project will have an insignificant impact on the other study intersections (generally resulting in less than a two percent increase in traffic relative to 2014 background conditions). At all signalized intersections beyond the site frontage (with the exception of the I-5 interchange), the project will add on average one vehicle or less per signal cycle to any movement. This level of impact is considered less than significant by traffic engineering standards and well below the level that would be perceived by motorists. The TIA concludes that anticipated vehicle queues can be accommodated at the I-5 ramp terminals and the SW Nyberg Road/Signalized site driveway.

Lastly, the Nyberg Rivers redevelopment project has proposed an on-site roadway network that will meet the intent of the City's loop road connection. The proposal includes the following:

- A new roadway connection to SW Boones Ferry Road (shown as "Street A" on Exhibit C that includes sidewalks.
- An enhanced site-access driveway to SW Nyberg Road that will better accommodate vehicular queuing and demand.
- A potential future (assuming the City desires to move forward) new site-access connection to SW Martinazzi Avenue that aligns across from SW Seneca Street. This connection would be the Seneca Street extension envisioned in the Town Center Plan. Prior to the City making a decision on any new SW Street Seneca alignment, the redevelopment site plan preserves this connection opportunity in the present or future.
- The preservation of east-west and north-south travel ways that will provide vehicular and pedestrian access between Street A, the Seneca Street alignment/extension, and enhanced access to SW Nyberg Road.
- New sidewalks along the enhanced site-access driveway to SW Nyberg Road that provide pedestrian connections to the integrated site circulation network.
- New bikeway connections along the perimeter of the site.

These findings aptly demonstrate that the proposed development provides "transportation access and circulation which is supportive of central area development" and is consistent with Objectives A and B above to support shared parking and the implementation of transportation improvements in the Community Plan and TSP.

GOAL 6: PEDESTRIAN AND BIKEWAYS

To develop a pedestrian/bicycle system linking the Urban Renewal Area to residential areas, parks, natural areas, and to link the business district on the south side of SW Boones Ferry Road to the future business district on the north side of SW Boones Ferry Road.

Objectives:

- a. Create pedestrian ways and bikeways to link the downtown area to the Community Park and to connect development on the north and south sides of SW Boones Ferry Road.**
- b. Provide sidewalks and lighting in the Urban Renewal Area where appropriate to encourage and support pedestrian-**

oriented activities in the downtown area. Provide rain protection where feasible.

- c. Create attractive pedestrian streetscapes in the downtown area (central sub-area).**

Response: As shown on the Nyberg Rivers Master Plan—Pedestrian and Bicycle Plan enclosed as Exhibit A with this project narrative, the master plan provides a pedestrian/bicycle system with an internal connectivity network for both east-west and north-south access, as well as linkage to the larger regional bicycle and pedestrian framework. These regional bicycle and pedestrian elements include the Ice Age Tonquin Trail, located west of the City Center and the Tualatin Commons area, as well as the Tualatin River Trail, located along the southern banks of the Tualatin River. Sidewalks and adequate lighting are provided throughout the Nyberg Rivers redevelopment site. Although this site is not within the central downtown sub-area, Nyberg Rivers does create attractive pedestrian streetscapes. Representative cross-sections are included with the master plan to demonstrate the theming and amenities that will be provided to create an attractive pedestrian streetscape.

GOAL 7: TRANSIT

To support the development of the metropolitan transportation system (Tri-Met) in order to provide alternative transportation modes for the residential and employment population of the Urban Renewal Area.

Objectives:

- a. Assist Tri-Met in locating park-and-ride facilities in outlying areas in the community, and assist in locating other transit-related facilities in the Urban Renewal Area.**
- b. Encourage design of private and public developments which integrate transit provisions.**
- c. Assist in locating commuter rail transit near the downtown area and mitigating impacts of train horn noise.**

Response: There is an existing Tri-Met bus route located just west of Nyberg Rivers, along SW Martinazzi Avenue and adjacent to the Tualatin Library and City Offices. The bus line is #76, with service between Tualatin and the Beaverton Transit Center along SW Boones and Lower Boones Ferry Road. The transit stop includes a covered waiting area with well-marked signage. This transit stop will be preserved with the redevelopment and pedestrian and bicycle linkages to this stop will also be improved to the transit stop as shown on the Master Plan.

PUBLIC UTILITIES

GOAL 8: UTILITIES

To assist in providing public utilities in the Urban Renewal Area as needed to facilitate growth and aesthetic quality.

Objectives:

- a. **Assist in improving, developing and relocating water, sewer, storm drainage and road systems within the Urban Renewal Area.**
- b. **Underground overhead electric, cable, and telephone lines in the downtown area and in all new development in the Urban Renewal Area. The Tualatin Commons Project Area and Central Design District Enhancement Project Area are the highest priority for undergrounding of utilities, to enhance the aesthetic value of the downtown.**

Response: The Nyberg Rivers Master Plan includes preliminary utility designs for on-site water, sewer, storm drainage and road infrastructure. Those preliminary plans are included with this project narrative. Generally, all electric, cable, and telephone lines will be underground.

RECREATIONAL AND COMMUNITY FACILITIES

GOAL 9: PARKS

To provide a high-quality park and recreation system to offset the environmental effect of large areas of commercial and industrial development.

Objectives (only relevant objectives listed):

- a. **Create green and open spaces centered around the Tualatin River, Nyberg Creek, Hedges Creek, and significant stands of trees.**
- c. **Link the downtown area to the Community Park with a system of pedestrian ways and bikeways.**
- d. **Preserve the natural value of the Tualatin River as a scenic, recreational and open space asset. Seek limitation of river use in this area to non-motorized boats.**

Response: As shown on the Nyberg Rivers Master Plan—Pedestrian and Bicycle Plan enclosed as Exhibit A with this project narrative, the master plan provides a pedestrian and bicycle linkage to the larger regional park and recreational system within and adjacent the community. The pedestrian and bicycle network helps link the site to the downtown core area and other park amenities such as These the Ice Age Tonquin Trail, located west of the City Center and the Tualatin Commons area, as well as linkage to the Tualatin River, located along the northern border of the Nyberg Rivers Master Plan area. The Master Plan includes a shared pathway easement is provided with this Master Plan for future development of a path along the Tualatin River. For those using that future path, the Master Plan links that path to the new pedestrian and bicycle network on-site, facilitating a greater overall connectivity as intended under the Goal 9 objectives.

FLOOD CONTROL AND OTHER PUBLIC IMPROVEMENTS

GOAL 10: FLOOD PROTECTION

To promote the public health, safety, and general welfare and to minimize public and private losses due to flood conditions.

Objectives (only relevant objectives listed):

- a. Provide flood protection for the Urban Renewal Area by participating in federal, state, and local flood control projects.
- b. Provide for the sound use and development of special flood hazard areas by utilizing special construction standards in the floodplain within the Urban Renewal Area. The Tualatin Development Code establishes standards for floodplain construction whereby structures must either be elevated above the floodplain or be made flood-proof.

Response: The northern portion of the Nyberg Rivers area is located within the 100-year Floodplain as mapped by FEMA and Metro. The majority of the area within the 100-year Floodplain is located outside of the area of impact for proposed development as shown on Exhibit C Site Plan. Site grading will ensure that all structures are located 2 feet above the 100-year floodplain, consistent with the Tualatin City Code. The proposed Master Plan has been designed consistent with the City, State and Federal government regulations that govern development within the floodplain.

GOAL 11: DESIGN CONSIDERATIONS

To create an atmosphere in the Urban Renewal Area which is aesthetically pleasing in order to promote the desirability of investment and occupancy in properties.

Objectives (only relevant objectives listed):

- c. Provide attractive and functional street and walkway lighting for public safety and convenience in the Urban Renewal Area.

Response: The applicant will be submitting for Architectural Review pending Master Plan review and approval. Despite this subsequent review, the Applicant seeks approval of its design proposal under this Master Plan process. The Master Plan includes a design submittal in Exhibit A. Design concepts for each elevation are provided demonstrating the high quality of the intended finishes as well as the architectural massing and articulation of each façade. Cross-sections are also provided to demonstrate the attractive and functional streetscape and walkway lighting. Together with the architectural massing, streetscape and walkway

lighting, the integrated landscape plan evokes the vegetation types of each major region of the state creating a sense of place and importance where the horizontal design elements are integrated with the vertical structures. Each of these design elements will not only greatly enhance the overall appearance of the site; they will also enhance public safety and convenience within the URA.

2. RELATIONSHIP TO LOCAL OBJECTIVES

The Tualatin Central Urban Renewal Plan exists to implement local objectives for central Tualatin, as they are expressed in the Tualatin Community Plan. The Urban Renewal Plan is a part of the Community Plan. The Community Plan and Planning District Standards together comprise the Tualatin Development Code.

The goals and objectives of the Urban Renewal Plan are based upon those in the Community Plan, as they relate to the Urban Renewal Area. The Urban Renewal Plan serves to further define local objectives as follows:

a. Land Use

The Plan calls for the promotion and support of Commercial (Goal 1), Residential (Goal 2), Industrial (Goal 3), and Civic (Goal 4) Development within the Urban Renewal Area. In particular, the Tualatin Commons Redevelopment Project and Central Design District Enhancement Project serve to further the local objective of establishing a socially and economically viable center in the community.

Response: The Tualatin Community Plan is comprised of Chapters 1-30 within the Development Code. The portion of the Community Plan pertaining to Commercial development within the Urban Renewal area is within Chapter 6: Commercial Planning Districts and Chapter 30: Tualatin Urban Renewal Plan. A response to the pertinent standards within Chapter 6 and Chapter 30 is provided below under those applicable headings. The site is outside the Tualatin Commons Redevelopment Project and Central Design District Enhancement areas, although the proposed design elements consider the context of these two areas.

b. Improved Traffic and Transportation

Goals 5 (Transportation), 6 (Pedestrian and Bikeways) and 7 (Transit) directly address objectives of the Transportation Element of the Community Plan and the Transportation System Plan. In particular, the plan calls for funding and construction of street improvements, pedestrian and bicycle facilities; for cooperation with Tri-Met in the placement of park-and-ride lots in outlying areas of the community, to encourage other facilities within the Urban Renewal Area; and to ensure adequate parking is provided within the redevelopment area.

Response: The findings above under Goals 5-7 are incorporated by reference herein in response to this criterion. The TIA aptly demonstrates that this proposal includes the construction of street improvements, pedestrian and bicycle improvements

and adequate parking in a manner that meets all of the City, County and state standards for transportation facilities.

c. Public Utilities

Goal 8 (Public Utilities) calls for Urban Renewal participation in design and construction of public utilities within the Urban Renewal Area. Such improvements are done in conformance with the Water and Sewer Service elements of the Community Plan and other applicable standards.

Response: The Nyberg Rivers Master Plan includes preliminary utility designs for on-site water, sewer, storm drainage and road infrastructure. Those preliminary plans are included with this project narrative in Exhibit A.

d. Recreational and Community Facilities

Goal 4 (Civic Development) includes an objective to participate in developing a community center and expansion of the public library. Goal 4 also includes an objective to develop a water feature in the Tualatin Commons Redevelopment Project as a way to encourage community-related private and public uses within the area. Goal 9 (Parks) includes objectives regarding linking the central area to the Community Park and preserving the scenic value of the Tualatin River, Hedges Creek and Nyberg Creek.

Response: As addressed under the Goal 9 above, incorporated herein by reference, and as shown on the Bicycle and Pedestrian Plan enclosed as Exhibit A, the Nyberg Rivers Master Plan provides a pedestrian and bicycle linkage to the larger regional park and recreational system. These regional elements include the Ice Age Tonquin Trail, located west of the City Center and the Tualatin Commons area, as well as linkage to the Tualatin River, located due north of Nyberg Rivers. A shared pathway easement is provided with this proposal to provide for future development of a trail network along the Tualatin River.

e. Flood Control and Other Public Improvements

The Plan has as a major activity implementation of flood control projects (Goal 10). The Plan anticipates Urban Renewal participation in additional projects which will serve to supplement the city's regulatory efforts described in the Tualatin Development Code, Flood Plain District Standards.

Response: As addressed under Goal 10, the northern portion of the Nyberg Rivers area is located within the 100-year Floodplain. The majority of this area is located outside of the area of impact for proposed development activity at Nyberg Rivers. Site grading will ensure that all structures are located above the floodplain. The site has been designed in conformance with all local, regional and federal floodplain regulations.

D. OUTLINE OF PROJECT ACTIVITIES

1. **PUBLIC IMPROVEMENTS**

b. **Roads and Streets**

The Transportation Study included in the 1977 plan amendments and the additional work included in the Review and Update of the Urban Renewal Plan and the City's Transportation System Plan 2001 have recommended revisions to the street and road system within the Urban Renewal Area. Transportation planning in Tualatin occurs within the context of the Transportation Element of the Community Plan. As a result of these studies, revisions were made to the Transportation Element.

The Transportation Element currently calls for the following improvements (displayed on Map 3, "Transportation") to be implemented within the Urban Renewal Area:

- **SW Nyberg Street**

This street will function as a major arterial between SW Tualatin-Sherwood Road on the west and SW 65th Avenue on the east. West of SW Tualatin-Sherwood Road bypass, SW Nyberg Street will function as a minor collector primarily as a main access point into the downtown area.

At the east end of the bridge, a loop ramp to accommodate the eastbound to northbound traffic was completed in the fall of 1991. This loop ramp was necessary because of the heavy left turn demand which required a double left turn lane. The existing bridge is not wide enough to accommodate two travel lanes in each direction and a double left turn lane, making the loop necessary. A free right turn onto westbound SW Nyberg Road from southbound I-5 is necessary to more effectively accommodate heavy travel movements to the employment centers.

Additional improvements are identified to the interchange due to significant congestion levels in the Urban Renewal Area. These include widening the southbound off ramp, widening the roadway from the K-Mart/Fred Meyer signal east which includes the overcrossing to accommodate two west bound lanes, west bound to south bound turn lane and four east bound lanes, turn lanes and pedestrian improvements.

Improvement of SW Nyberg Street from the K-Mart driveway to SW Martinazzi Avenue including road widening and pedestrian improvements may be necessary to serve the land use of the Tualatin Commons Redevelopment Area, Central Design District Project Area and other developments in the central and east sub-areas of the Urban Renewal area.

SW Nyberg Street, from SW Martinazzi to SW Boones Ferry Road will function as a local downtown street and should be developed with two travel lanes and on-street parking. Portions may be closed, realigned, or rebuilt depending on the location of the major water feature in the Tualatin Commons Redevelopment Project or the Central Design District Enhancement Project. Closure will require specific authorization from the City Council. The status of this segment will be addressed during site planning efforts related to the Tualatin Commons Redevelopment Project.

- **SW Martinazzi Avenue**
This roadway will function as a minor arterial from SW Tualatin-Sherwood Road to SW Nyberg and should be widened to accommodate two lanes of traffic, center left turn lanes, bike lanes and a signal at SW Seneca Street. From SW Nyberg Street to the southern edge of the District the roadway will function as a major arterial and should be widened to accommodate four lanes of traffic, a center turn lane or medians and pedestrian amenities.

Response: Some of these listed projects are included in this application request to be constructed by a private developer. For instance, a new roadway connection to SW Boones Ferry Road (shown as "Street A" in Figure 2) that includes sidewalks.

- An enhanced site-access driveway to SW Nyberg Road that will better accommodate vehicular queuing and demand.
- A potential future (assuming the City desires to move forward) new site-access connection to SW Martinazzi Avenue that aligns across from SW Seneca Street. This connection would be the Seneca Street extension envisioned in the Town Center Plan. Prior to the City making a decision on any new SW Street Seneca alignment, the redevelopment site plan preserves this connection opportunity in the present or future.
- The preservation of east-west and north-south travel ways that will provide vehicular and pedestrian access between Street A, the Seneca Street alignment/extension, and enhanced access to SW Nyberg Road.
- New sidewalks along the enhanced site-access driveway to SW Nyberg Road that provide pedestrian connections to the integrated site circulation network.
- New bikeway connections along the perimeter of the site.

In particular, the Nyberg Street improvements and the new Loop Road through the site directly implement this desired project list.

Specific Project Activities, Road and Street Improvements: The Plan proposes to participate in the following improvements to the road and street system within the Urban Renewal Area:

Road Improvements:

- **SW Nyberg Street west of K-Mart to SW Martinazzi Avenue. Improvements may be constructed in conjunction with the Tualatin Commons Redevelopment Project or Central Design District Enhancement Project, including rebuilding and widening of road and pedestrian improvements.**

Response: The proposed road improvements along SW Nyberg Street are not being constructed in conjunction with the Commons Redevelopment or Central Design District Enhancement Project. However, the Applicant is proposing to add a new 350-foot westbound right-turn lane at the SW Nyberg Road/signalized site driveway at the K-Mart entrance.

c. Utilities

Improvements in sanitary sewer, storm sewer, water supply, and electricity systems have been Plan activities since the establishment of the Urban Renewal Area. The Report (Section B.1.) describes the original and current conditions of these systems. The Water Service and Sewer Service Elements of the Community Plan state the city's policies and procedures regarding system improvements. The improvements within the Urban Renewal Area are shown on Maps 13-18 of the Report.

Response: Based on the Maps 13-18 provided in the Urban Renewal Report, there are existing utilities that currently serve the site. Map 14 shows an existing 8-inch sanitary sewer line that extends into the site from near the Library, heading east to serve the existing retail pads. Map 16 shows existing storm lines providing service to the site, a 12-inch storm lines lies within Nyberg Street and 18-inch and 21-inch lines within Martinazzi Road. Map 18 shows an existing 10-inch water line within SW Nyberg Street and 8-inch lines extended into the site from Nyberg and Martinazzi Road. All proposed improvements and updates to the existing utilities are shown on the Site Utility Plan, provided with this submittal. The proposed Master Plan is consistent with maps 13-18.

F. LAND USE

Land use within the Urban Renewal Area is governed by the Planning District Standards contained in the Tualatin Development Code. The Urban Renewal Area contains the following Planning District Designations:

- **Central Commercial**
- **Office Commercial**
- **General Commercial**
- **General Manufacturing**
- **Light Manufacturing**
- **High Density Residential/High Rise**
- **High Density Residential**

The regulations governing development within these districts are summarized in Table 2 and Map 7, "Planning Districts and Blocks," displays the Planning District designations within the Urban Renewal Area.

In some cases, the Plan calls for additional considerations to be applied to land uses within the Urban Renewal Area. These apply to specific "blocks" as shown on the Planning Districts Map (Map 7). These considerations pertain to permitted land uses, minimum lot sizes, and requirements for "Master Planning" of entire blocks or groups of blocks.

Response: Map 2 of the 2009 Urban Renewal Report displays the land use designations throughout the Urban Renewal Area. The Nyberg Rivers Master Plan site contains areas designated Central Commercial (CC), Office Commercial (CO), and High Density Residential (RH). All of the proposed uses on the site are permitted where they are located in each zoning district.

SUMMARY OF PLANNING DISTRICTS USES

1. PERMITTED USES

In addition to the uses normally permitted within the relevant Planning District, the Planning District Standards allow the following additional permitted and conditional uses in the areas listed (only sections relevant to the subject property, Blocks 1-5 are cited below):

Permitted uses:

- c. Uses permitted in the Residential High Density District on Block 1.
- d. Multi-family uses and single-family common-wall residential units are allowed on Blocks 2, 3, 15, 16, 17, 18, 19, 20, 22 and 23.

Conditional Uses:

- b. Uses permitted in the Central Commercial Planning District on Block 1.

Response: The Nyberg Rivers Master Plan includes Urban Renewal Area Blocks 1, 2, 3, and 5. Both the Urban Renewal Plan and the underlying CO, CC and RH zoning district regulations apply to the site. In addition to the uses permitted by the underlying zoning districts, the Urban Renewal Plan allows additional uses on Block 1 as cited above. Block 1 is zoned CO. The Urban Renewal Plan expands the allowed uses on Block 1 to all of those uses permitted under the CO zone (as the underlying zoning district) as well as the "uses permitted in the Residential High Density District" and "uses permitted in the Central Commercial Planning District..." (See subsections (c) and (b) above). The Applicant is proposing a sporting goods store as one use on the site. The sporting goods store is located within a portion of Block 1 zoned CO and a portion of Block 2 zoned CC. Sporting goods stores are permitted uses in the CC District and are therefore, under the Urban Renewal Plan, permitted uses in the CC district and conditional uses in the CO district within Block 1. Outdoor storage and sales is permitted under Chapter 32 within the CC district. Thus, the conditional use permit narrative below seeks approval of the outdoor storage and sales as a conditional use in the CC district and seeks approval for the portion of the sporting goods

store that is located in the CC District. The conditional use narrative is provided below.

2. STRUCTURE HEIGHT

The following structure heights are permitted within the relevant Planning Districts and Blocks:

- b. Buildings constructed on Blocks 1, 2, 3, 5, 14, 15, 16, 17, 18, 19, and 22 can be a maximum of 60 feet in height.
- c. 35 feet between the Tualatin Commons central water feature and the primary pedestrian corridor, except for architectural focal elements.
- d. 75 feet for Architectural Focal Elements for Blocks 14, 17, 18 and 20.

Response: The Master Plan comprises only Blocks 1, 2, 3 and 5. The Applicant is aware of the maximum structure heights within the relevant Planning Districts. The maximum height allowed for the applicable blocks is 60-feet. The Applicant is not proposing any structures or design elements that will exceed 60 feet in height. The building elevations provided in the Master Plan document and included as a part of Exhibit C show that the proposed development is well below the 60-foot maximum height allowance.

3. MINIMUM LOT SIZES

Within the Urban Renewal Area, the Planning District Standards allow for minimum lot sizes that are generally in excess of the normal Planning District requirements. This is to allow for development which can incorporate a greater number of design features, e.g. landscaping, to achieve the design objectives of the Plan. The following minimum lot sizes shall apply to the creation of new lots by partition, subdivision or lot line adjustment in the Planning Districts and Blocks listed:

- a. Unless otherwise noted, minimum lot sizes within the Urban Renewal Area are 25,000 square feet.
- b. Minimum lot sizes within the Core Area Parking District are 5,000 square feet.

Response: A lot consolidation is proposed with the Nyberg Rivers Master Plan that would result in Tax Lots 2507 and 2700 being consolidated into one (1) legal lot. The resulting lot size is approximately 13.07 acres, well in excess of the 25,000 square foot URA minimum.

4. REQUIREMENTS FOR MASTER PLANNING

Prior to approval of applications for development projects within Blocks 1, 2, 3, 4, 5, 13, 25, 26, 27, 31, 32, and 33, applicants will be required to submit and gain City approval of a master plan governing development within the Block(s). Such

master plan shall contain sufficient information, as determined by the City, to ensure that development meets the objectives of the Plan. Master plans may include, but are not limited to, treatment of such issues as access, transportation, sewer, water storm drainage, internal circulation, building location, building design and materials, parking, landscaping and pedestrian facilities.

Master plans for Blocks 1, 2, 3, 4, 5, 13, 25, 26, 27, 31, 32, 33, as well as subsequent modifications to those plans, must be approved by the City Council at a public hearing. The public hearing shall be called and conducted in the manner provided for in Section 1.031 of the Tualatin Development Code. In approving a master plan, the City Council may attach conditions that it finds necessary to achieve the objectives of the Urban Renewal Plan.

For blocks within which land is under multiple ownerships, and where special conditions exist, the Commission may initiate master plans to govern development. Block 23, because of its unusual platting pattern and the difficulty of providing street access may require such master planning.

Plans developed by the Commission for those purposes will be referenced within the Development Code.

Response: The Applicant is aware of the requirements applicable for master planning. As the site is located within Blocks 1, 2, 3 and 5, the Applicant is submitting for master plan approval, consistent with this requirement. This master plan and the development plan shown on the Site Plan address the Primary Development Area. The remaining areas are designated as Future Development Area(s). The Primary Development Area is controlled by the Applicant. The Future Development Area(s) are anticipated to be pursued and completed by third parties.

This project narrative together with the attached exhibits, addresses all applicable master plan elements, as well as Tualatin Municipal and Development Code provisions. The Applicant is also aware that this proposal is subject to a public hearing before the City Council.

III. TUALATIN MUNICIPAL CODE (TMC)

CHAPTER 03-05: SOIL EROSION, SURFACE WATER MANAGEMENT, WATER QUALITY FACILITIES, AND BUILDING AND SEWERS

EROSION CONTROL

3-5-010 POLICY.

It is the policy of the City to require temporary and permanent measures for all construction projects to lessen the adverse effects of construction on the environment. The contractor shall properly install, operate and maintain both temporary and permanent works as provided in this chapter or in an approved plan, to protect the environment during the term of the project. In addition, these erosion control rules apply to all properties within the City, regardless of whether that property is involved in a construction or development activity. Nothing in this chapter shall relieve any person from the obligation to comply with the regulations or permits of any federal, state, or local authority. [Ord. 846-91 §1, 10/28/1991]

Response: The applicant is aware of the erosion control requirements for all construction projects. At the time of construction staging, the contractor will properly install, operate and maintain erosion control measures consistent with City requirements. The applicant's representative will be submitting for an Erosion Control Permit pending Master Plan approval.

3-5-050 EROSION CONTROL PERMITS.

- (1) Except as noted in subsection (3) of this section, no person shall cause any change to improved or unimproved real property that causes, will cause, or is likely to cause a temporary or permanent increase in the rate of soil erosion from the site without first obtaining a permit from the City and paying prescribed fees. Such changes to land shall include, but are not limited to, grading, excavating, filling, working of land, or stripping of soil or vegetation from land.
- (2) No construction, land development, grading, excavation, fill, or the clearing of land is allowed until the City has issued an Erosion Control Permit covering such work, or the City has determined that no such permit is required. No public agency or body shall undertake any public works project without first obtaining from the City an Erosion Control Permit covering such work, or receiving a determination from the City that none is required.

Response: The Applicant will seek and obtain approval of an Erosion Control Permit prior to any ground disturbing activities that require an Erosion Control Permit under this section.

ADDITIONAL SURFACE WATER MANAGEMENT STANDARDS

3-5-200 DOWNSTREAM PROTECTION REQUIREMENT.

Each new development is responsible for mitigating the impacts of that development upon the public storm water quantity system. The development may satisfy this

requirement through the use of any of the following techniques, subject to the limitations and requirements in [TMC 3-5-210](#):

- (1) Construction of permanent on-site stormwater quantity detention facilities designed in accordance with this title;
- (2) Enlargement of the downstream conveyance system in accordance with this title and the Public Works Construction Code;
- (3) The payment of a Storm and Surface Water Management System Development Charge, which includes a water quantity component designated to meet these requirements. [Ord. 846-91 §20, 10/28/1991]

Response: The proposed project includes the construction of public and private storm sewer lines. All on-site surface water will be captured, conveyed and treated through an on-site stormwater system before discharged into the public system. Public storm lines have been designed for Street "A" and SW Seneca Street extension with treatment from Contech stormfilter structures. Additionally, a public storm line with a 15-foot easement has been proposed behind the proposed retail buildings (1005, 1010, and 1040). The public line then runs south to serve the property in the southeast corner of the site and the acquired ODOT land (proposed buildings F-100 and G-100). A private storm line will be extended to the north for connections to proposed buildings J-100, M-100, and N-100. The storm service for existing buildings "A", "B", and "C" will remain in place, but will be retrofit with Contech stormfilter structures to treat the existing impervious area.

The remainder of the site will be captured in sumped catch basins and conveyed to Contech stormfilter structures. Sumped catch basins and Contech stormfilter structures are an approved pretreatment and treatment device per the City of Tualatin and Clean Water Services. A detailed Storm Drainage Plan and Drainage Report is submitted as a separate exhibit demonstrating compliance with this criterion.

3-5-210 REVIEW OF DOWNSTREAM SYSTEM.

For new development other than the construction of a single family house or duplex, plans shall document review by the design engineer of the downstream capacity of any existing storm drainage facilities impacted by the proposed development. That review shall extend downstream to a point where the impacts to the water surface elevation from the development will be insignificant, or to a point where the conveyance system has adequate capacity, as determined by the City Engineer.

To determine the point at which the downstream impacts are insignificant or the drainage system has adequate capacity, the design engineer shall submit an analysis using the following guidelines:

- (1) evaluate the downstream drainage system for at least ¼ mile;
- (2) evaluate the downstream drainage system to a point at which the runoff from the development in a build out condition is less than 10 percent of the total runoff of

the basin in its current development status. Developments in the basin that have been approved may be considered in place and their conditions of approval to exist if the work has started on those projects;

- (3) evaluate the downstream drainage system throughout the following range of storms: 2, 5, 10, 25 year;
- (4) The City Engineer may modify items 1, 2, 3 to require additional information to determine the impacts of the development or to delete the provision of unnecessary information.

If the increase in surface waters leaving a development will cause or contribute to damage from flooding, then the identified capacity deficiency shall be corrected prior to development or the development must construct onsite detention. To determine if the runoff from the development will cause or contribute to damage from flooding the City Engineer will consider the following factors:

- (1) The potential for or extent of flooding or other adverse impacts from the run-off of the development on downstream properties;
- (2) The potential for or extent of possibility of inverse condemnation claims;
- (3) Incremental impacts of runoff from the subject and other developments in the basin; and
- (4) Other factors that may be relevant to the particular situation.

The purpose of the City Engineer's review is to protect the City and its inhabitants from the impacts or damage caused by runoff from development while recognizing all appropriate limitations on exactions from the development. [Ord. 846-91 §21, 10/28/1991; Ord. 972-97 §1, 2/24/1997]

Response: According to the Drainage Report provided with this Master Plan application, the proposed private stormwater conveyance systems were modeled using xpswmm modeling software and were designed to convey the 25-year storm event with a maximum 82% full capacity. A downstream analysis is not required for this project as the site discharges directly into the Tualatin River. The final design of the stormwater treatment and conveyance system will be reviewed by City staff to ensure conformance with all applicable local, regional (CWS), State and Federal requirements.

3-5-220 CRITERIA FOR REQUIRING ON-SITE DETENTION TO BE CONSTRUCTED.

The City shall determine whether the onsite facility shall be constructed. If the onsite facility is constructed, the development shall be eligible for a credit against Storm and Surface Water System Development Charges, as provided in City ordinance.

On-site facilities shall be constructed when any of the following conditions exist:

- (1) There is an identified downstream deficiency, as defined in [TMC 3-5-210](#), and detention rather than conveyance system enlargement is determined to be the more effective solution.

- (2) There is an identified regional detention site within the boundary of the development.
- (3) There is a site within the boundary of the development which would qualify as a regional detention site under criteria or capital plan adopted by the Unified Sewerage Agency.
- (4) The site is located in the Hedges Creek Subbasin as identified in the Tualatin Drainage Plan and surface water runoff from the site flows directly or indirectly into the Wetland Protected Area (WPA) as defined in [TDC 71.020](#). Properties located within the Wetland Protection District as described in [TDC 71.010](#), or within the portion of the subbasin east of SW Tualatin Road are excepted from the on-site detention facility requirement. [Ord. 846-91 §22, 10/28/1991; Ord. 952-95 § 4, 10/23/1995]

Response: The proposed project includes the construction of public and private storm sewer lines. All on-site surface water will be captured, conveyed and treated through an on-site stormwater system before discharged into the public system. Public storm lines have been designed for Street "A" and SW Seneca Street extension with treatment from Contech stormfilter structures. Additionally, a public storm line with a 15-foot easement has been proposed behind the proposed retail buildings (1005, 1010, and 1040). The public line then runs south to serve the property in the southeast corner of the site and the acquired ODOT land (proposed buildings F-100 and G-100). A private storm line will be extended to the north for connections to proposed buildings J-100, M-100, and N-100. The storm service for existing buildings "A", "B", and "C" will remain in place, but will be retrofit with Contech stormfilter structures to treat the existing impervious area.

The remainder of the site will be captured in sumped catch basins and conveyed to Contech stormfilter structures. Sumped catch basins and Contech stormfilter structures are an approved pretreatment and treatment device per the City of Tualatin and Clean Water Services. A Storm Drainage Plan and Drainage Report are enclosed with this application for proposed layouts and more information. The proposed stormwater system for the master plan does not propose to connect into a facility that has an existing downstream deficiency as described by TMC 3-5-210. There currently are no existing regional detention facilities located within the master plan area nor are there any existing detention facilities within the master plan area that would qualify as a regional facility. The site is not located within the Hedges Creek Subbasin, all stormwater runoff will be treated and released into the Tualatin River or Nyberg Creek. Therefore no on-site detention is required to be constructed.

3-5-230 ON-SITE DETENTION DESIGN CRITERIA.

- (1) Unless designed to meet the requirements of an identified downstream deficiency as defined in [TMC 3-5.210](#), stormwater quantity onsite detention facilities shall be designed to capture run-off so the run-off rates from the site after development do not exceed predevelopment conditions, based upon a 25-year, 24-hour return storm.

- (2) When designed to meet the requirements of an identified downstream deficiency as defined in [TMC 3-5.210](#), stormwater quantity on-site detention facilities shall be designed such that the peak runoff rates will not exceed predevelopment rates for the 2 through 100 year storms, as required by the determined downstream deficiency.
- (3) Construction of on-site detention shall not be allowed as an option if such a detention facility would have an adverse effect upon receiving waters in the basin or subbasin in the event of flooding, or would increase the likelihood or severity of flooding problems downstream of the site. [Ord. 846-91 §23, 10/28/1991]

Response: The applicant is not proposing to construct any on-site detention facilities nor are any required pursuant to 3-5-220. Therefore, these criterion are not applicable to this review.

3-5-240 ON-SITE DETENTION DESIGN METHOD.

- (1) The procedure for determining the detention quantities is set forth in Section 4.4 Retention/Detention Facility Analysis and Design, King County, Washington, Surface Water Design Manual, January, 1990, except subchapters 4.4.5 Tanks, 4.4.6 Vaults and Figure 4.4.4G Permanent Surface Water Control Pond Sign. This reference shall be used for procedure only. The design criteria shall be as noted herein. Engineers desiring to utilize a procedure other than that set forth herein shall obtain City approval prior to submitting calculations utilizing the proposed procedure.
- (2) For single family and duplex residential subdivisions, stormwater quantity detention facilities shall be sized for the impervious areas to be created by the subdivision, including all residences on individual lots at a rate of 2640 square feet of impervious surface area per dwelling unit, plus all roads which are assessed a surface water management monthly fee under Unified Sewerage Agency rules. Such facilities shall be constructed as a part of the subdivision public improvements. Construction of a single family or duplex residence on an existing lot of record is not required to construct stormwater quantity detention facilities.
- (3) All developments other than single family and duplex, whether residential, multi-family, commercial, industrial, or other uses, the sizing of stormwater quantity detention facilities shall be based on the impervious area to be created by the development, including structures and all roads and impervious areas which are assessed a surface water management monthly fee under Unified Sewerage Agency rules. Impervious surfaces shall be determined based upon building permits, construction plans, site visits or other appropriate methods deemed reliable by City. [Ord. 846-91 §24, 10/28/1991]

Response: The applicant is not proposing to construct any on-site detention facilities nor are any required pursuant to 3-5-220. Therefore, these criterion are not applicable to this review.

3-5-250 FLOODPLAIN DESIGN STANDARDS.

(1) Balanced Cut and Fill Standard.

All fill placed in a floodplain shall be balanced with an equal amount of removal of soil material. No net fill in any floodplain is allowed with two exceptions:

- (a) When an engineering study has been conducted and approved by the City showing that the increase in water surface elevation resulting from the fill will not cause or contribute to significant damage from flooding to existing buildings or dwellings on properties upstream and downstream;
- (b) When an area has received special protection from floodplain improvement projects which either lower the floodplain, or otherwise protect affected properties, are approved by the City, where the exceptions comply with adopted master plans, if any, and where all required permits and approvals have been obtained in compliance with other local, state, and federal laws regarding fill in floodplains, including FEMA rules.

(2) Excavation Restricted.

Large areas may not be excavated in order to gain a small amount of fill in a floodplain. Excavation areas shall not exceed the fill areas by more than 50 percent of the square footage, unless approved by the City.

(3) Excavation and Fill Volume Calculation.

Any excavation dug below the winter "low water" elevation shall not count towards compensating for fill, since these areas would be full of water in the winter, and not available to hold storm water following a rain. Winter "low water" elevation is defined as the water surface elevation during the winter when it has not rained for at least three days, and the flows resulting from storms have receded. This elevation may be determined from records, studies or field observation. Any fill placed above the 100 year floodplain will not count towards the fill volume.

(4) Excavation Grade Design Standard.

The excavated area must be designed to drain if it is an area identified to be dry in the summer; for example, if it is to be used for a park, or if it is to be mowed in the summer. Excavated areas identified as to remain wet in the summer, such as a constructed wetland, shall be designed not to drain. For areas that are to drain, the lowest elevation should be at least six inches above the winter "low water" elevation, and sloped at a minimum of two percent towards the drainage way. One percent slopes will be allowed in small areas.

(5) Excavation Location.

Excavation to balance a fill does not need to be on the same property as the fill, but shall be in the same drainage basin, within points of constriction on the conveyance system, if any, as near as practical to the fill site, and shall be constructed as a part of the same development project which placed the fill. [Ord. 846-91 §25, 10/28/1991]

Response: There is no proposed cut or fill that will occur within the 100-year floodplain. This approval criteria is therefore not applicable.

3-5-260 FLOODWAY DESIGN STANDARDS.

(1) Obstruction Prohibited.

Nothing may be constructed or placed in a floodway that will impede or constrict the flow of storm water. This includes, but is not limited to earth works, street and bike path crossings, and trees. If an object is placed in the floodway, the floodway must be widened or modified to accommodate the storm flows with no measurable increase in water surface elevation upstream or downstream, or unless the property owners of property where the water surface increase occurs grant written permission by agreement or easement.

The floodway may not be modified such that water velocities are increased such that stream bank erosion will be increased, unless the stream banks are protected to prevent an increase in erosion.

(2) Floodway Modifications.

Any proposed work within or modification to a floodway must be certified by an Oregon Registered Professional Engineer as meeting the requirements of [TMC 3-5.250\(1\)](#).

(3) Floodway Identification.

For streams, creeks, rivers and other watercourses where the City has not identified the floodway, the entire floodplain shall be treated as a floodway, or a study prepared by an Oregon Registered Professional Engineer and approved by the City may be used to define the floodway limits for a stream section. [Ord. 846-91 §26, 10/28/1991]

Response: There is no proposed work proposed within the Floodway. This approval criteria is therefore not applicable.

3-5-280 PLACEMENT OF WATER QUALITY FACILITIES.

Title III specifies that certain properties shall install water quality facilities for the purpose of removing phosphorous. No such water quality facilities shall be constructed within the defined area of existing or created wetlands unless a mitigation action, approved by the City, is constructed to replace the area used for the water quality facility. [Ord. 846-91 §28, 10/28/1991; Ord. 972-97 § 3, 2/24/1997; Ord. 1068-01 §2, 3/26/2001; Ord. 1068-01, 03/26/2001]

Response: The Applicant is not proposing to construct water quality facilities within existing or proposed wetlands. The Applicant has provided a Preliminary Drainage report

submitted with this application that provides detailed stormwater design and demonstrates that this criteria is not applicable.

PERMANENT ON-SITE WATER QUALITY FACILITIES

3-5-290 PURPOSE OF TITLE.

The purpose of this title is to require new development and other activities which create impervious surfaces to construct or fund on-site or off-site permanent water quality facilities to reduce the amount of phosphorous entering the storm and surface water system. [Ord. 846-91 §29, 10/28/1991]

Response: This project represents redevelopment and new development that will result in additional impervious surfaces. The treatment of stormwater within the redevelopment project will be conveyed to Contech StormFilters facilities. StormFilters are an approved treatment device per the City of Tualatin and Clean Water Services (CWS). A Storm Drainage Plan and Drainage Report enclosed with this application provide the detailed design and function of the proposed system that reduces the amount of phosphorous entering the storm and surface water system.

3-5-330 PERMIT REQUIRED.

Except as provided in [TMC 3-5-310](#), no person shall cause any change to improved or unimproved real property that will, or is likely to, increase the rate or quantity of run-off or pollution from the site without first obtaining a permit from the City and following the conditions of the permit. [Ord. 846-91 §33, 10/28/1991]

Response: The Applicant is aware of this requirement and has designed a stormwater system in compliance with this criteria. The Applicant will obtain all necessary permits prior to development activity commencing within the plan area.

3-5-340 FACILITIES REQUIRED.

For new development, subject to the exemptions of [TMC 3-5-310](#), no permit for construction, or land development, or plat or site plan shall be approved unless the conditions of the plat, plan or permit approval require permanent stormwater quality control facilities in accordance with this Title III. [Ord. 846-91 §34, 10/28/1991; Ord. 1323-11 §1, 6/13/2011]

Response: This project provides on-site permanent water quality control facilities. The treatment of stormwater on the redevelopment project will be conveyed to Contech StormFilters facilities. StormFilters are an approved treatment device per the City of Tualatin and Clean Water Services. A Storm Drainage Plan and Drainage Report are enclosed with this application. The Applicant is aware of this requirement and will obtain all necessary permits prior to development activity commencing within the plan area.

3-5-345 INSPECTION REPORTS.

The property owner or person in control of the property shall submit inspection reports annually to the City for the purpose of ensuring maintenance activities occur according to the operation and maintenance plan submitted for an approved permit or architectural review. [Ord. 1319-11§6, 3/28/2011]

Response: The Applicant is aware of this requirement and will submit inspection reports annually according to an operation and maintenance plan submitted to and approved by the City.

3-5-350 PHOSPHOROUS REMOVAL STANDARD.

The stormwater quality control facilities shall be designed to remove 65 percent of the phosphorous from the runoff from 100 percent of the newly constructed impervious surfaces. Impervious surfaces shall include pavement, buildings, public and private roadways, and all other surfaces with similar runoff characteristics. [Ord. 846-91 §35, 10/28/1991]

Response: The Applicant is aware of the phosphorous removal standard. The treatment of stormwater on the redevelopment project will be conveyed to Contech StormFilters facilities. StormFilters are an approved treatment device per the City of Tualatin and Clean Water Services. The StormFilters are designed to remove at least 65 percent of the phosphorous from 100 percent of the newly constructed impervious surface. A Storm Drainage Plan and Drainage Report are enclosed with this application that provides detailed design drawings demonstrating compliance with this criteria. .

3-5-360 DESIGN STORM.

The stormwater quality control facilities shall be designed to meet the removal efficiency of [TMC 3-5-350](#) for a mean summertime storm event totaling 0.36 inches of precipitation falling in four hours with an average return period of 96 hours. [Ord. 846-91 §36, 10/28/1991]

Response: The treatment of stormwater on the redevelopment project will be conveyed to Contech StormFilters facilities. StormFilters are an approved treatment device per the City of Tualatin and Clean Water Services. The Storm Drainage Plan and Drainage Report submitted with this application demonstrate that these facilities are designed to meet the removal efficiency standard for a mean summertime storm event totaling .36 inches of precipitation falling in four hours with an average return period of 96 hours.

3-5-380 CRITERIA FOR GRANTING EXEMPTIONS TO CONSTRUCTION OF ON-SITE WATER QUALITY FACILITIES.

On-site facilities shall be constructed as required by [OAR 340-41-455](#), unless otherwise approved by the City on a case by case basis due to the size of the development, topography, or other factors causing the City to determine that the construction of onsite permanent stormwater treatment systems is impracticable or undesirable.

Determinations by the City may be based upon, but not limited to, consideration of the following factors:

Response: No exemption is requested with this Master Plan application. Therefore, this criterion does not apply.

3-5-390 FACILITY PERMIT APPROVAL.

A stormwater quality control facility permit shall be approved only if the following are met:

- (1) The plat, site plan, or permit application includes plans and a certification prepared by an Oregon registered, professional engineer that the proposed stormwater quality control facilities have been designed in accordance with criteria expected to achieve removal efficiencies for total phosphorous required by this Title III. Clean Water Services Design and Construction Standards shall be used in preparing the plan for the water quality facility; and
- (2) The plat, site plan, or permit application shall be consistent with the areas used to determine the removal required in [TMC 3-5-350](#); and
- (3) A financial assurance, or equivalent security acceptable to the City, is provided by the applicant which assures that the stormwater quality control facilities are constructed according to the plans established in the plat, site plan, or permit approval. The financial assurance may be combined with our financial assurance requirements imposed by the City; and
- (4) A stormwater facility agreement identifies who will be responsible for assuring the long term compliance with the operation and maintenance plan. [Ord. 846-91 §39, 10/28/1991; Ord. 1323-11 §3, 06/13/2011]

Response: The Applicant is aware of the requirements needed to achieve stormwater quality control permit approval. This project will achieve the needed requirements.

3-5-400 SYSTEM DEVELOPMENT CHARGE.

If under [TMC 3-5-380](#), an on-site facility will not be constructed, the Storm and Surface Water System Development Charge shall be paid. [Ord. 846-91 §40, 10/28/1991]

Response: On-site facilities are feasible based on the existing site topography and type of development being proposed. Therefore, the applicant is not seeking an exemption as outlined in TMC 3-5-380. An on-site facility will be constructed for Nyberg Rivers, so storm and surface water SDCs will not be paid.

3-5-410 PERMIT FEE.

The City shall collect a reasonable fee established by the Council by resolution for the review of plans, administration, enforcement and field inspection to carry out the provisions of this title. [Ord. 846-91 §41, 10/28/1991]

Response: The Applicant is aware that permit fees will apply in order to conduct proper review of plans, administration, enforcement, and field inspection for water quality facility permitting.

3-5-420 RESIDENTIAL DEVELOPMENTS.

The permanent stormwater quality control facilities for the construction of any single family and duplex subdivision shall be adequately sized for the public improvements of the subdivision and for the future construction of single family and duplex houses on the individual lots at a rate of 2,640 square feet of impervious surface per dwelling unit. [Ord. 846-91 §42, 10/28/1991]

Response: This criterion does not apply.

3-5-430 PLACEMENT OF WATER QUALITY FACILITIES.

No water quality facilities shall be constructed within the defined area of existing or created wetlands unless a mitigation action is approved by the City, and is constructed to replace the area used for water quality. [Ord. 846-91 §43, 10/28/1991]

Response: No water quality facilities will be constructed within the defined area of existing or created wetlands.

IV. TUALATIN DEVELOPMENT CODE (TDC)

TDC 6: COMMERCIAL PLANNING DISTRICTS

SECTION 6.010 BACKGROUND.

- (1) Commercial development in Tualatin has occurred primarily in the downtown area and near the City's two Interstate 5 Freeway interchanges at Lower Boones Ferry Road and Nyberg Street. Downtown development consists mostly of retail, service, and office uses ranging in size from small, locally owned firms to large national chain stores such as K-Mart. Development near the interchanges is predominantly automobile-oriented and includes motels, automobile service stations, and restaurants. [Ord. 849-91, §3, 11/25/91]
- (2) At present, there are approximately 165 acres of land zoned for commercial use, but only a little over 1/3 of this land is developed. Two factors account for the bulk of the undeveloped commercial land. First, much of this land is in large parcels (10 or more acres) owned by a few major developers such as Schnitzer Investment Corporation. These firms have held their land in anticipation of economic conditions favorable to large-scale commercial development. Second, much of the undeveloped commercial land is in the 100-year flood plain of the Tualatin River

and is thus subject to additional development costs necessary to comply with applicable flood plain regulations.

- (3) Despite the large amount of undeveloped commercial land, a number of factors suggest that this land will be needed for commercial use during the planning period. First, the demand for additional goods and services will increase as Tualatin's population increases. Greater concentrations of population and the relatively high incomes of the area's residents will support increasingly specialized types of retail and service establishments. It should be noted that the adjoining communities of Durham, Rivergrove and Lake Grove are predominantly residential in character, with relatively little commercial development. Consequently, growth of these cities will increase the demand for available commercial land in Tualatin, particularly near the Lower Boones Ferry Road interchange with I-5. Second, the Lower Boones Ferry Road interchange area is subject to continued development pressure because of its accessibility for freeway travelers looking for gasoline, food, or lodging on their way to and from Portland. And finally, the City is located adjacent to three of the region's major transportation routes, the Interstate 5 and 205 Freeways and the State Highway 217 Expressway. This access to the remainder of the region and to the Willamette Valley provides an opportunity for larger-scale commercial and freeway-oriented developments.
- (4) It should be noted that while most of Tualatin's residents work elsewhere, they will more likely work in the City if diversified job opportunities are available. Tualatin's supply of commercial land will thus eventually create additional diverse job opportunities and hopefully decrease Tualatin residents' needs to travel out of the community to find jobs.
- (6) As much of the City's commercial land area is visible from the Interstate 5 Freeway and because all residents of Tualatin must pass through a commercial area before reaching their homes, it is important that aesthetic design in commercial areas be sensitively handled. Generally, the design of a community's commercial area defines much of the community's character. Fortunately, the City has an Architectural Review process and an Urban Renewal Agency to help prevent inappropriate, unattractive development, but much more could be done to increase the quality of architectural and landscape design in commercial areas. Because much of Tualatin's commercial land is forested, is visible from the freeway, or is adjacent to residential uses, land-extensive commercial uses, such as automobile, truck and machinery sales and rental, would be more appropriately located in the City's Western Industrial District where there are relatively large, flat and un-forested parcels of land. This area will have good access to freeways, and land-extensive commercial uses would not affect the industrial uses planned for this area.

Response: Nyberg Rivers represents a commercial development that will include anchor tenants and supporting smaller retail tenants to provide a mix of retail, service, and office uses within the approximate 26 acre site. This site is directly adjacent to the Tualatin City Center, due east from the City Center and Tualatin Commons area, and is bounded to the east by Interstate 5. As this development is near the interchange, the proposed master plan does include parking to suit regional visitors, as well as pedestrian and bicycle networks to accommodate people

seeking to access the site via the Tualatin River Trail, local bike/pedestrian networks, or the Ice Age Tonquin trail located west of the downtown. Nyberg Rivers represents a commercial development that will serve local Tualatin consumers and a larger, regional consumer base, all in an intimate and aesthetically pleasing environment created at an appropriate pedestrian scale. Building elevations and plan views are provided with this application to demonstrate the general aesthetic that will be created on-site.

SECTION 6.020 ASSUMPTIONS.

The following are general assumptions used to formulate this Plan:

- (1) Demand for the City's commercial land will increase.
- (2) Large-scale commercial enterprises will find Tualatin an increasingly attractive location.
- (3) The City will become a commercial center serving a population much larger than its own.
- (4) Retail commercial enterprises will locate primarily in the City's downtown area.
- (5) Freeway service establishments and offices will locate adjacent to the City's freeway interchanges or will be visible from the Interstate 5 Freeway.
- (6) Demand for hospital-related commercial development will occur near Meridian Park Hospital.
- (7) The creation of residential and employment concentrations away from the downtown core will create the need for neighborhood commercial centers. These centers are intended to provide for day-to-day shopping and service needs and are not intended to be serious competition with businesses in the downtown area. [Ord. 592-83, § 26, 6/13/83]

Response: The Applicant is aware of the assumptions used to formulate the Plan. As demand for the City's commercial land increases and Tualatin's presence as a regional attractor of large-scale commercial enterprises grows, the uses and intensities proposed at Nyberg Rivers will be a perfect complement to the vision of the Plan. The increased investment and level of development proposed is consistent with the intent of the assumptions outline above.

SECTION 6.030 OBJECTIVES

The following are general objectives used to guide the development of this Plan:

- (1) Encourage commercial development.
- (2) Provide increased employment opportunities.
- (3) Provide shopping opportunities for surrounding communities.

- (4) Locate and design commercial areas to minimize traffic congestion and maximize access.
- (5) Continue to utilize specific and enforceable architectural and landscape design standards for commercial development.
- (6) Encourage developers to consider solar access when designing commercial development projects.
- (7) Provide for limited and carefully designed neighborhood commercial centers.
- (8) Provide for the continued development of major medical services facilities in the City of Tualatin, especially at the Meridian Park Hospital site. The Medical Center Planning District shall be applied only to a property, or a group of contiguous properties, of no less than 25 acres and shall have frontage on an arterial as designated in TDC Chapter 11, Tualatin Community Plan.
- (9) To work with the applicable jurisdictions and agencies to develop the Durham Quarry Site and Durham Quarry Area with high quality development. It is appropriate to apply an overlay district on the Durham Quarry Site and Durham Quarry Area to allow mixed commercial/residential uses. It is appropriate to enter into an intergovernmental agreement with the City of Tigard and Washington County to allow the City of Tualatin to review and decide land use applications and building permit applications for the portion of the Durham Quarry Site in the City of Tigard. [Ord. 592-83, §27, 6/13/83; Ord. 827-91, §2, 3/25/91; Ord. 1062.00, §2, 12/11/00; Ord. 1133-03, 3/24/03; Ord. 1062-00, 1/03/01]

Response: The Applicant is aware of the purpose of each commercial planning district outlined above. Nyberg Rivers represents a commercial redevelopment that provides increased employment opportunities, enhanced transportation networks, and architectural and landscape designs that create a sense of place and are designed to a pedestrian appropriate scale. These elements will work to integrate with the existing City Center and Tualatin Commons fabric in order to create a more comprehensive and vibrant vision for Tualatin.

SECTION 6.040 COMMERCIAL PLANNING DISTRICT OBJECTIVES.

This section describes the purpose of each commercial planning district.

- (1) **Office Commercial Planning District (CO).** To provide areas suitable for professional office uses adjacent to or across from residential areas. Restaurants may be allowed by conditional use permit when designed as an integral part of a major office complex. It is the intent of this district to provide for office development ranging in size from small buildings with one or two tenants to large complexes housing business headquarters offices. In the design of development in this district, care shall be taken to preserve significant natural resources and to provide extensive perimeter landscaping, especially adjacent to residential areas and streets.
- (4) **Central Commercial Planning District (CC).** To provide areas for a full range of retail, professional and service uses of the kinds usually found in downtown areas patronized by pedestrians. Civic, social and cultural functions that serve the

general community are also appropriate. The Central Commercial Planning District is almost entirely within the downtown portion of the urban renewal area. The Urban Renewal Plan contains extensive development policies and design standards that apply to this district. These policies and standards are intended to help create a village atmosphere in the down-town area. Multiple-family housing is appropriate in certain areas of this district, as specified in the Urban Renewal Plan.

Response: Nyberg Rivers is located within the Office Commercial (CO), Central Commercial (CC) and High Density Residential (RH) planning districts. The northeast portion of the site is within the CO district, while the property fronting SW Nyberg Street has the CC designation. Based on the proposed Site Plan, the CO district will include commercial uses permitted in the CO District. The CC district is focused on commercial retail users, with a full range of retail, professional and service uses. The uses will work well to complement the existing retail uses located within the City Center and the Tualatin Commons. As demonstrated in this narrative, the proposed Master Plan does address all applicable Urban Renewal Plan development policies and design standards that apply to each commercial district.

TDC 9: PLAN MAP

SECTION 9.010 BACKGROUND.

This Plan section includes the Plan Map, ([Map 9-1](#)) classification of planning district boundaries, and brief descriptions of the land uses in each Plan area. The Plan Map is a synthesis of the objectives contained in each Plan element that can be portrayed graphically in map form. The Map is based on an analysis of data contained in the Phase I - Technical Memoranda, Northwest Tualatin Concept Plan 2005 and an analysis of Plan objectives and the Statewide Planning Goals of the Land Conservation and Development Commission. [Ord. 635-84, §4, 6/11/84; Ord. 1191-05, 6/27/05]

Response: The Applicant does have a copy of the Community Plan Map—Planning Districts (Map 9-1) and is aware of the planning district boundaries for each area. Nyberg Rivers is located within the Office Commercial (CO), Central Commercial (CC) and High Density Residential (RH) planning districts. The northeast portion of the site is within the CO district, while the property fronting SW Nyberg Street has a CC designation. The RH designation applies to the existing residential area located in the northwest corner of the site.

SECTION 9.020 PLANNING DISTRICT BOUNDARIES.

The boundaries between planning districts, as portrayed on the Plan Map, are intended to follow property lines (or extensions thereof), roadways, or natural features such as creeks. Where such definition was not possible, the Map is drawn to scale and district boundaries can be determined by using this scale. It should be noted that property lines shown on the Plan Map were derived from County Assessor's Maps and are therefore relatively accurate. Consequently, the planning districts shown on the Plan shall be considered zoning districts, as normally termed. This eliminates the need for two sets of

maps and simplifies the understanding of what land uses may be allowed on an individual property.

Response: The Applicant is aware of the planning district boundaries and where each district boundary does occur. This project does occur across several property lines and proposed uses will occur across both CO and CC districts.

SECTION 9.025 TUALATIN DESIGN TYPE BOUNDARIES.

- (1) [Map 9-4](#), Tualatin Design Type Boundaries, shows the City's final location of the Metropolitan Service District's Growth Concept Design Types. Metro adopted the general location of the Design Types as part of adopting the Urban Growth Management Functional Plan (UGMFP) ([Metro Code, Chapter 3](#)). The UGMFP, Title 1, says, "For each of the following 2040 Growth Concept design types, city and county comprehensive plans shall be amended to include the boundaries of each area, determined by the city or county consistent with the general locations shown on the 2040 Growth Concept Map: " [Map 9-4](#) shows the location of the applicable Design Types consistent with the general locations shown on the 2040 Growth Concept Map. The boundaries are intended to follow the Planning District Boundaries, property lines, rights-of-way centerlines and water features.

Response: The Applicant is aware of the design type boundaries outlined on Map 9-4 of the Community Plan. The entire site is within the Town Center (TC) design area. The City has not yet adopted any Town Center zoning regulations. Metro's Town Center designation is contained within Title 6. Title 6 was recently amended by Metro and has not yet been acknowledged. In turn, Metro Code Section 3.07.810 states that Title 6 requirements are not directly applicable to the City until one year after acknowledgment. Therefore, while the site is within a Town Center design area, there are no specific Town Center regulations yet applicable to the site.

SECTION 9.030 AREA DESCRIPTIONS.

To clarify the Plan Map, the Map has been divided into 14 plan areas, and the following describes, in narrative form, the permitted uses for each plan area. All Plan Areas with the exception of those comprising commercial and industrial lands, provide the framework for neighborhood organizations. It was with this in mind that the plan areas were drawn. Each area, with the exception stated above, was viewed as a potential neighborhood unit, having its own area of interest, comprising a population of 3,000 to 5,000 persons and served, as much as possible, by common facilities such as schools or parks. [Ord. 635-84, §5, 6/11/84]

Response: Nyberg Rivers is within Area 1, which is the area generally described as the City's central area and the City's Central Urban Renewal area. A description of that area is provided below under Section 9.031—Area 1.

SECTION 9.031 AREA 1.

This portion of the Plan comprises the City's central area and is described in the City's adopted Central Urban Renewal Plan. The Central Urban Renewal Plan is a separate plan, but considered an element of this Plan. This Plan has been drafted to minimize any land use conflicts between uses on the periphery of the Central Urban Renewal Area. [Map 9-3](#), "Central Tualatin Urban Renewal Area Planning Districts," shows the Central Urban Renewal boundary, the Core Area Parking District boundary, land use blocks within the Central Urban Renewal Area, minimum lot sizes for blocks within the Central Urban Renewal Area, and the designation of which blocks require a Master Plan to be submitted for development. [Ord. 694-86, §1, 5/27/86; Ord. 1109-02, 4/22/02]

Response: Nyberg Rivers is within Area 1 and is included as a part of the Central Urban Renewal Area, although it is outside the Core Area Parking District shown on Map 9-3. This map also shows the land use blocks within the Central Urban Renewal Area. Nyberg Rivers encompasses land within Blocks 1, 2, 3 and 5. These blocks require Master Plan review and approval prior to redevelopment.

TDC 11: TRANSPORTATION

SECTION 11.610 TRANSPORTATION GOALS AND OBJECTIVES.

- (1) Established at the outset of the TSP planning process, the transportation goals and objectives provide guidance and direction for the development of the City of Tualatin's transportation system over the next twenty years. A total of eleven goals have been developed in the categories of mobility, livability, coordination, public transportation, pedestrian and bicycle facilities, accessibility, environment, system preservation, capacity, transportation funding, and safety. Under each of these goals are sets of objectives that help define how each specific goal will be accomplished.

Response: The Applicant is aware of the transportation goals and objectives established under the recently adopted February 2013 TSP update. The eleven goals are addressed below, with responses provided for each goal.

- (2) **Goal 1: Mobility**
Provide a transportation system that serves the travel needs of Tualatin residents, businesses, and visitors.

Objectives

- (a) Provide an interconnected system of streets, pedestrian and bicycle facilities, and other forms of transportation which will link the community; minimize travel distances and vehicle-miles traveled; and safely, efficiently, and economically move motor vehicles, pedestrians, bicyclists, transit vehicles, trucks, and trains to and through the area when it is fully urbanized.
- (b) Act within the police power of the City as the City Road Authority and in conjunction with the State and Washington and Clackamas County road

authorities to protect the safety of the general public by regulating the flow, access and movement of traffic within the City.

- (c) Encourage and support programs that help the City meet Metro's 2040 mode share targets, including, but not limited to, ride-sharing, flexible work hours and the Transportation Management Association.
- (d) Discourage residential development patterns, such as single-entrance subdivisions and gated communities, which reduce connectivity and mobility options for all members of the community.
- (e) For Plan Map and Text Amendments adopt a Level of Service standard F for the p.m. peak hour and E for the one-half hour before and after the p.m. peak hour for the Town Center 2040 Design Type ([Map 9-4](#)), and E/E for the rest of the 2040 Design Types. For development applications, including, but not limited to subdivisions and architectural reviews, a LOS of at least D and E are encouraged for signalized and un-signalized intersections, respectively.

Response: As discussed previously within this narrative, the streets and pedestrian and bicycle facilities proposed at Nyberg Rivers provide an interconnected system that allows access both to and through the site, with linkages to the existing regional transportation system. The enclosed Pedestrian & Bicycle Plan included with the Master Plan document does show the street and pedestrian and bicycle network for the area. Also, as supporting evidence for the proposed transportation improvements, a TIA prepared by Kittelson and Associates is included with this application. The TIA identifies several significant transportation improvements that are proposed as part of the development of this project and demonstrates that the applicable City, Washington County and ODOT operating standards are met. The transportation findings provided previously in this application are incorporated herein by reference.

- (3) **Goal 2: Livability**
Provide a transportation system that balances user needs with the community's desire to remain a pleasant, economically vital city.

Objectives

- (a) Provide a transportation system that is adequate to handle the truck, transit, and automobile traffic in such a way to encourage industrial development, the preservation of existing residential neighborhoods, the minimization of industrial traffic and congestion in the Town Center area, and the successful implementation of the City's economic development goals.
- (b) Minimize the adverse social, economic and environmental impacts created by the transportation system, including balancing the need for street connectivity with the need to minimize neighborhood cut-through traffic.

- (c) Work with surrounding local governments, Washington and Clackamas Counties, Metro, Oregon Department of Transportation, and Tri-Met to develop alternate transportation facilities that will allow development without major disruption of existing neighborhoods or downtown.
- (d) Incorporate a landscape element into the development plans of arterials, collectors and local streets.
- (e) Preserve and protect Tualatin's historic sites, where practicable, when developing new transportation facilities.
- (f) Ensure safe and efficient access to the Tualatin Town Center.

Response: The streets and pedestrian and bicycle facilities proposed at Nyberg Rivers do contribute to a transportation system that balances user needs with the Tualatin community's desire to remain a pleasant, economically vital city. The internal street system is proposed to provide adequate vehicle access and flow through the site while encouraging safe pedestrian and bicycle interaction with those vehicles. The Nyberg Rivers Master Plan—Transportation Plan, included under Exhibit A with this application, displays the proposed network as well as sample cross-sections of those transportation elements. Heavier freight and delivery traffic is focused to the back portion of the site, with greater access to the back of the larger retail buildings. The proposed transportation improvements noted in a TIA prepared by Kittelson and Associates will work to improve the transportation network and ensure safe and efficient access both to the Nyberg Rivers site and the adjacent Tualatin Town Center. The transportation findings provided previously in this application are incorporated herein by reference.

- (4) **Goal 3: Coordination**
 Maintain a transportation system plan that is consistent with the goals and objectives of the community, the region, and the state.

Objectives

- (a) Provide a City transportation system that is consistent with other elements and objectives of the Tualatin Community Plan.
- (b) Coordinate planning of the City transportation system with the Regional Transportation Plan prepared by the Metro, working toward a plan that is consistent with the RTP.
- (c) Work with Metro, ODOT, Tri-Met, Washington County, Clackamas County, and other surrounding organizations/jurisdictions to resolve regional and statewide transportation issues that impact Tualatin, including developing one or more arterial routes connecting I-5 and Highway 99W south of Highway 217, ensuring adequate capacity on the freeway system, and improving access to and the capacity of I-5 interchanges between Highway 217 and the North Wilsonville Interchange.

Response: The proposed updates to the transportation system in and around Nyberg Rivers represent changes that are more in line with the goals and objectives of a

coordinated transportation plan. Specifically, the streets and pedestrian and bicycle facilities proposed at Nyberg Rivers provide an interconnected system that allows access both to and through the site, with linkages to the existing regional transportation system. Also, as supporting evidence for the proposed transportation improvements, a TIA prepared by Kittelson and Associates is included with this application. The TIA defines the proposed transportation improvements along with the levels of service to provide safe and efficient transportation options. Those improvements include:

- An on-site roadway network that will meet the intent of the City's loop road connection. The proposal includes the following:
 - A new roadway connection to SW Boones Ferry Road (shown as "Street A" in Figure 2 of the TIA) that includes sidewalks.
 - An enhanced site-access driveway to SW Nyberg Road that will better accommodate vehicular queuing and demand.
 - A potential future (assuming the City desires to move forward) new site-access connection to SW Martinazzi Avenue that aligns across from SW Seneca Street. This connection would be the Seneca Street extension envisioned in the Town Center Plan. Prior to the City making a decision on any new SW Street Seneca alignment, the redevelopment site plan preserves this connection opportunity in the present or future.
 - The preservation of east-west and north-south travel ways that will provide vehicular and pedestrian access between Street A, the Seneca Street alignment/extension, and enhanced access to SW Nyberg Road.
 - New sidewalks along the enhanced site-access driveway to SW Nyberg Road that provide pedestrian connections to the integrated site circulation network.
 - New bikeway connections along the perimeter of the site.
 - Closure of the existing SW 75th Avenue site-access driveway to SW Nyberg Road to minimize turning movement conflicts, allow for construction of a westbound right-turn lane at SW Nyberg Road/signalized site driveway, and to improve the interchange access spacing conditions along SW Nyberg Road.
 - A new 350-foot westbound right-turn lane constructed on SW Nyberg Road

These elements will work to create a more efficient and coordinated transportation system within Nyberg Rivers and the City Center.

- (5) **Goal 4: Public Transportation**
Improve public transportation service both within Tualatin and to the surrounding

area, to reduce reliance on the private automobile.

Objectives

- (a) Support and assist whenever practicable, the development of the metropolitan public transportation system through cooperation with the Tri-County Metropolitan Transportation District (Tri-Met).
- (b) Working through Tri-Met, develop transit systems and stations, park and ride systems, and related facilities in convenient and appropriate locations that adequately and efficiently serve the residential and employment populations.
- (c) Work to create or improve local transit service within Tualatin either through Tri-Met or other local agencies; quick, direct transit service to adjacent communities; and high capacity inter-city transit service, where appropriate.

Response: There is an existing Tri-Met bus route located just west of Nyberg Rivers, along SW Martinazzi Avenue and adjacent to the Tualatin Library and City Offices. The bus line is #76, with service between Tualatin and the Beaverton Transit Center along SW Boones and Lower Boones Ferry Road. The transit stop includes a covered waiting area with well-marked signage. This bus line should work to provide public transportation service for users of the Nyberg Rivers commercial center.

- (6) **Goal 5: Pedestrian and Bicycle Facilities**
Provide for an interconnected system of pedestrian and bicycle facilities throughout Tualatin to serve short-distance and recreational trips.

Objectives

- (a) Provide sidewalks on both sides of all fully developed streets within the City, except where it would be unsafe to do so.
- (b) Develop safe and convenient pedestrian and bicycle systems that link all land uses, provide connections to transit facilities, and provide access to publicly-owned land intended for general public use.
- (c) Maintain and update official map showing existing and future street rights-of-way with bicycle lanes and bikeways.
- (d) Develop a continuous multi-use pathway along the Tualatin River, and provide opportunities for pedestrian and bicycle movement across the river.
- (e) Adopt development standards that support pedestrian and bicycle access to commercial, industrial, and institutional development. These include, but are not limited to direct pathway connections, bicycle racks and lockers, and shower facilities.
- (f) Allow curb extensions and pedestrian crossing refuges where appropriate.

Response: The pedestrian and bicycle facilities proposed at Nyberg Rivers contribute to an interconnected system that ties into the existing City network. The proposed internal street system provides sidewalks on both sides of the street, while pedestrian and bicycle accessways are provided into and through the site in both a north-south and east-west direction. The Nyberg Rivers Master Plan—Pedestrian & Bicycle Plan, included under Exhibit A with this application, displays the proposed network as well as sample cross-sections of those transportation elements. The internal accessways do provide access to the Tualatin River Trail, as well as the regional Ice Age Tonquin Trail located west of the City Center.

- (7) **Goal 6: Accessibility**
Provide a transportation system that serves the needs of all members of the community.

Objectives

- (a) Provide for the transportation disadvantaged by complying with state and federal regulations concerning this matter and cooperating with local, county and regional agencies providing transportation services for the disadvantaged.
- (b) Upgrade existing transportation facilities and work with public transportation providers to ensure services that improve access for all users.

Response: The proposed transportation system upgrades provide accessibility from ADA compliant parking stalls to the primary entrances to each building and access to the Tri-Met bus station located west of the site along SW Martinazzi Avenue in compliance with this criteria.

- (8) **Goal 7: Environment**
Provide a transportation system that protects the environment of the community and region.

Objectives

- (a) Provide a transportation system which encourages energy conservation, in terms of efficiency of the road network and in the standards developed for street improvements.
- (b) Cooperate with the Department of Environmental Quality, Clean Water Services, and Metro to meet applicable air and water quality and traffic noise standards.
- (c) Encourage use of the existing transportation facilities by increasing use of alternative modes of transportation and encourage development that decreases reliance on the automobile.
- (d) Balance transportation improvements with the need to protect natural resources.

- (e) **Provide authority for the City Engineer to modify right-of-way widths and street improvement widths to address unusual conditions.**

Response: The proposed updates to the transportation infrastructure at Nyberg Woods does promote greater pedestrian and bicycle access, which will put less stress on the transportation system. Also, with the proposed system upgrades proposed under the TIA performed by Kittelson, greater vehicle efficiency and movement will be achieved. The site is also designed for shared parking amongst uses and with the mix of uses will promote internal pedestrian site trips to lessen overall vehicle trips. These elements combine to provide a transportation system that better protects the environment of the community and region.

- (9) **Goal 8: System Preservation**
Ensure that development does not preclude the construction of identified future transportation improvements, and ensure that development mitigates the transportation impacts it generates.

Objectives

- (c) **Require developers to aid in the development of the transportation system by dedicating or reserving needed rights-of-way, and by constructing half or full street improvements needed to serve new development and to mitigate the impacts of new development.**
- (d) **Require developers to mitigate the impacts of development on the transportation system by constructing off-street pedestrian, bicycle and transit facilities.**
- (e) **Establish local street plans for contiguous vacant and re-developable areas of five acres or more planned or zoned for development that identify local street access points to the collector and arterial street system, and local street connections to adjacent development.**

Response: The proposed Nyberg Rivers development does include several updates to the transportation infrastructure. Those updates include:

- The Nyberg Rivers redevelopment project has proposed an on-site roadway network that will meet the intent of the City's loop road connection. The proposal includes the following:
 - A new roadway connection to SW Boones Ferry Road (shown as "Street A" in Figure 2 of the TIA) that includes sidewalks.
 - An enhanced site-access driveway to SW Nyberg Road that will better accommodate vehicular queuing and demand.
 - A potential future (assuming the City desires to move forward) new site-access connection to SW Martinazzi Avenue that aligns across from SW Seneca Street. This connection would be the Seneca Street extension envisioned in the Town Center Plan. Prior to the City making a decision on any new SW Street Seneca alignment, the redevelopment site plan preserves this connection opportunity in the present or future.

- The preservation of east-west and north-south travel ways that will provide vehicular and pedestrian access between Street A, the Seneca Street alignment/extension, and enhanced access to SW Nyberg Road.
- New sidewalks along the enhanced site-access driveway to SW Nyberg Road that provide pedestrian connections to the integrated site circulation network.
- New bikeway connections along the perimeter of the site.
- Closure of the existing SW 75th Avenue site-access driveway to SW Nyberg Road to minimize turning movement conflicts, allow for construction of a westbound right-turn lane at SW Nyberg Road/signalized site driveway, and to improve the interchange access spacing conditions along SW Nyberg Road.
- A new 350-foot westbound right-turn lane constructed on SW Nyberg Road

The site design also facilitates connections to surrounding properties and does not preclude the development of other transportation facilities consistent with the TSP. These commitments by the applicant will work to create a more efficient and coordinated transportation system within Nyberg Rivers and the City Center.

(10) Goal 9: Capacity

Provide a transportation system that has sufficient capacity to serve user needs.

Objectives

- (a) Establish an arterial street system which will attract and effectively accommodate all “through” trips to relieve residential collectors and local streets from heavy and hazardous traffic burdens.**
- (b) Locate proposed rail spur lines to minimize conflicts with adjoining land uses and streets.**
- (c) Minimize new railroad grade crossings to reduce time losses due to traffic delays and accidents, and to produce in-creased efficiency of railroad operation and increased public convenience.**
- (d) Maintain and update the City’s access management standards in the Tualatin Development Code to preserve the safe and efficient operation of the City’s roadways, consistent with their functional classification.**

Response: All of the study intersections, site access points, and internal site intersections, except for the previously identified SW Martinazzi Avenue/SW Sagert Road and SW 65th Avenue/SW Sagert Road intersections, are forecast to operate with acceptable operating standards during the weekday p.m. and Saturday midday peak hours.

The project will have an insignificant impact at either the SW Martinazzi Avenue/SW Sagert Road or the SW 65th Avenue/SW Sagert Road intersections (the project will result in a less than 1.5 percent increase in traffic at either intersection).

Beyond the site's frontage along SW Tualatin Sherwood Road and SW Martinazzi, where significant transportation improvements are proposed (including implementing the intent of the City's Loop Road), the project will have an insignificant impact on the other study intersections (generally resulting in less than a two percent increase in traffic relative to 2014 background conditions).

At all signalized intersections beyond the site frontage (with the exception of the I-5 interchange), the project will add on average one vehicle or less per signal cycle to any movement. This level of impact is considered less than significant by traffic engineering standards and well below the level that would be perceived by motorists.

Anticipated vehicle queues can be accommodated at the I-5 ramp terminals and the SW Nyberg Road/Signalized site driveway.

The Nyberg Rivers redevelopment project has proposed an on-site roadway network that will meet the intent of the City's loop road connection. The proposal includes the following:

- A new roadway connection to SW Boones Ferry Road (shown as "Street A" in Figure 2) that includes sidewalks.
- An enhanced site-access driveway to SW Nyberg Road that will better accommodate vehicular queuing and demand.
- A potential future (assuming the City desires to move forward) new site-access connection to SW Martinazzi Avenue that aligns across from SW Seneca Street. This connection would be the Seneca Street extension envisioned in the Town Center Plan. Prior to the City making a decision on any new SW Street Seneca alignment, the redevelopment site plan preserves this connection opportunity in the present or future.
- The preservation of east-west and north-south travel ways that will provide vehicular and pedestrian access between Street A, the Seneca Street alignment/extension, and enhanced access to SW Nyberg Road.
- New sidewalks along the enhanced site-access driveway to SW Nyberg Road that provide pedestrian connections to the integrated site circulation network.
- New bikeway connections along the perimeter of the site.

With these improvements, the development will maintain sufficient capacity to serve users' needs in compliance with this goal.

- (11) **Goal 10: Transportation Funding**
Provide reasonable and effective funding mechanisms for citywide transportation

improvements identified in the transportation system plan.

Objectives

- (a) **Develop a Capital Improvements Program and funding mechanisms for all transportation facilities that complies with the requirements of Statewide Planning Goal 12, Transportation, and the Transportation Planning Rule, including making provisions for alternative modes of transportation that will reduce reliance on the automobile, and reduce air pollution and traffic congestion.**

Response: This goal pertains to City identified funding mechanisms for citywide transportation improvements than private sector funding mechanisms. The applicant is aware of the Washington County transportation development tax (TDT) applicable to development projects in Washington County.

(12) Goal 11: Safety

Provide a transportation system that maintains adequate levels of safety for all users.

Objectives

- (a) **Undertake, as needed, special traffic studies in problem areas, especially around schools, to determine appropriate traffic controls to effectively and safely manage automobile and pedestrian traffic.**
- (b) **Work to improve the safety of rail, bicycle, and pedestrian routes and crossings. [Ord. 1103-02, 3/25/02; Ord. 1224-06 §2, 11/13/06]**

Response: The proposed Nyberg Rivers development does include several updates to the transportation system that provides greater levels of safety for all users. The proposed updates create greater efficiency by limiting access to SW 75th Avenue and creating more turn lanes for both ingress and egress to the site. A shared-facility driveway is provided through the site, with pedestrian sidewalks providing both an east-west and north-south network for pedestrian access to and through the site. The Nyberg Rivers Master Plan—Transportation Plan, included under Exhibit A with this application, displays the proposed networks as well as sample cross-sections of those transportation elements.

SECTION 11.620 STREET SYSTEM PLAN.

(2) Tualatin Functional Classification Plan

The purpose of classifying roadways is to create a mechanism through which a balanced transportation system can be developed that facilitates mobility for all modes of transportation. A roadway’s functional classification determines its intended purpose, the amount and character of traffic it is expected to carry, the degree to which non-auto travel is emphasized, and the roadway’s design standards. It is imperative that a roadway’s classification considers the adjacent land uses and the transportation modes that should be accommodated. The public right-of-way must also provide sufficient space for utilities to serve adjacent land uses.

The functional classification system for the City of Tualatin establishes fifteen functional categories to address the City's needs for mobility and accessibility. These categories include: freeways, expressways, major arterials, minor arterials, major collectors, minor collectors, residential collectors, local commercial industrial streets, and local streets. Table 11-1 provides a detailed description of each category.

Figure 11-1 presents the functional classifications for all existing and future roadways within the Tualatin planning area. The alignment for future streets should be considered conceptual: the end points of the streets are fixed, but the alignments between intersections may vary depending on design requirements at the time the street is constructed. Table 11-2 presents a summary of the streets assigned to each functional classification (except local).

Response: Based on the designations shown on Figure 11-1, SW Nyberg Street and SW Martinazzi Avenue are classified as a Major Arterials (Eb & T) across the Nyberg Rivers frontage. The internal roadways are classified as Minor Collectors (Cb), with access from Seneca Street and Boones Ferry Rd and Nyberg St.

The applicant has designed a transportation system that provides the same form and function as articulated within the TSP. The applicant is proposing to provide access for a new connection from the site to Boones Ferry Road. The Master Plan anticipates the future realignment of Seneca Street within the City of Tualatin property. The Applicant has provided for efficient vehicular connections through the site providing direct connections to the surrounding transportation system.

The Applicant has provided for an enhanced pedestrian connection between the Nyberg Street, Boones Ferry Road, and Martinazzi Avenue through the redevelopment of the site. The streetscape along the proposed and existing buildings will be improved. New landscaping will separate the east-west pedestrian corridor and will be coupled with plaza space, outdoor eating and seating areas to create an inviting experience for pedestrians. The Master Plan provides an easement so the City can continue to develop the Tualatin River Trail and provide a connection to the Ice Age Trail.

(3) Street Design Standards

Street design standards are based on the functional and operational characteristics of streets such as travel volume, capacity, operating speed, and safety. They are necessary to ensure that the system of streets, as it develops, will be capable of safely and efficiently serving the traveling public while also accommodating the orderly development of adjacent lands.

The proposed street design standards are implemented by the standards in TDC Chapter 75 and shown in Figures 75-2A through 75-2G. The typical roadway cross sections comprise the following elements: right-of-way, number of travel lanes, bicycle and pedestrian facilities, and other amenities such as landscape strips. The B-skinny typical street section shows a 46-foot right-of-way with a 4-foot plant strip, but it also could be a 50-foot right-of-way with a 6-foot plant strip. These figures are intended for planning purposes for new road construction, as well as for those locations where it is physically and economically feasible to improve

existing streets. TDC Chapter 75, Table 75-1 presents the standards in tabular form. As more than one standard may exist for a given functional class, Figure 11-1 indicates the standard assigned to each roadway segment.

Where a variable sidewalk width is shown for a particular facility, the greater width is used for sidewalks within the pedestrian district shown on the Tualatin Pedestrian Plan (Figure 11-4), and for side-walks along streets with potential transit service shown on the Tualatin Transit Plan (Figure 11-6). The greater width may also be appropriate for sidewalks adjacent to significant pedestrian generators including but not limited to parks and schools.

Response: Figure 75-2B provides the recommended arterial street design standards for a Major Arterial (Eb & T), while Figure 75-2D addresses Minor Collector design, although classification Cb is not shown. The Major Arterial Eb & T design standards show a ROW width of 98 to 102-feet, with four (4) travel lanes, a central turn lane or landscape median, 6-foot bikelanes on each side, a 6-foot planting strip, and a 6 to 8-foot sidewalk. The applicant is proposing a 350-foot right-turn lane on SW Nyberg Street that provides access into the central signalized driveway at Nyberg Rivers, as well as a 6-foot bikelane that will run along the SW Nyberg portion of the roadway frontage the project site.

The internal transportation system is shown on the Nyberg Rivers Master Plan—Transportation Plan, included under Exhibit A with this application. The graphic included with the transportation plan displays the proposed networks as well as sample cross-sections of those transportation elements in compliance with the street design standards. Street A includes the design elements found in a Collector roadway, which incorporates 2-travel lanes, a bicycle lane, detached sidewalks, and a landscape strip planter.

(4) Access Management

Managing access to the City's road system is necessary to preserve the capacity of the City's arterial street system, by minimizing the number of points where traffic flow may be disrupted by traffic entering and exiting the roadway, and to enhance safety along all City roadways by minimizing the number of potential conflict points. The City of Tualatin has developed specific descriptions of where access will occur on the City's arterial street system, which can be found in TDC Chapter 75.

Where a facility is maintained by Washington County, Clackamas County, and/or ODOT, or is within the influence area of an interchange, as defined by ODOT, the City should coordinate with the appropriate agencies about whether or how access will be provided.

Response: As proposed in the TIA, Kittelson recommends limiting access to SW 75th Ave from Nyberg Street. The access management will work to preserve the capacity of the City's arterial street system by minimizing the number of points where traffic flow may be disrupted. This proposed access management is even more critical considering the short distance to the I-5 interchange. Proposed Street "A" would be a right-in and right-out a connection to Boones Ferry, with no new access points proposed for Nyberg Street.

(6) **Traffic Operations Considerations**

Metro has adopted lowered traffic operations standards in the RTP, in recognition that insufficient funding is available to improve all of the region's roadways to provide desirable peak hour levels of service. Metro uses a two-hour standard, allowing higher levels of congestion during the peak hour in key areas such as the Tualatin Town Center, as long as better operations can be achieved during the hour-hour periods on either side of the peak hour. The Metro peak hour standard for the Tualatin Town Center is a peak hour volume-to-capacity (v/c) ratio of 1.10 or less, with a v/c ratio of 1.00 allowed during the second hour. Appendix G (Transportation System Plan, Resolution 3878-01) describes current standards in more detail.

The RTP identifies the Tualatin Town Center area as an "area of special concern", as key roadways within the Town Center area will not meet even Metro's lowered operations standards in the long term. The RTP calls for the TSP to develop a traffic management plan addressing the ability of local streets in the area to absorb some of the traffic demand, and to establish specific plans and benchmarks for facilities determined to exceed the LOS policy. Because the RTP was adopted after the TSP project was scoped and funded, this plan was not developed through the TSP and will need to be developed separately at a later date. The TSP's implementation plan calls for a Transportation Growth Management Program project to address this need. The City's long-term LOS standards for the Town Center area will be determined through this project.

The City of Tualatin has decided to use the Regional Transportation Plan's Level of Service (LOS) for the area of Town Center 2040 Design Type of F for the p.m. peak hour and E for the one-half hour before and after the p.m. peak hour, and E/E for the rest of the area in the rest of the 2040 Design Types in the City's planning area. The LOS E/F and E/E will be used for transportation system planning and plan text and plan map amendments, but not for development applications. Development applications, including but not limited to subdivisions and architectural reviews, are encouraged to meet at least a LOS D and E for signalized and unsignalized intersections, respectively.

The City of Tualatin has decided to maintain its current practice of using LOS "D" as its minimum standard for signalized intersections and LOS "E" as its minimum standard for unsignalized intersections, as defined by the Highway Capacity Manual, for areas outside the Tualatin Town Center. The intent of the higher standard is to maintain reasonable operations for all transportation modes operating on public roadways, and to allow development to continue to pay its share of traffic impacts. A volume-to-capacity ratio greater than 1.00 should also be considered to be below the minimum standard, regardless of level of service. Where a facility is maintained by Washington County, Clackamas County, or ODOT, the more restrictive of the City's or the other agency's standards should apply.

The projects included in the TSP's Implementation Plan (TDC 11.730) collectively achieve this LOS standard. However, the financially constrained plan does not achieve the standard. [Ord. 1151-03, 11/10/03; Ord. 1103-02, 3/25/02; Ord. 1191-05; 6/27/05]

Response: The TIA demonstrates that with the proposed transportation improvements all of the study intersections will continue to operate at acceptable levels of service during the weekday p.m. and Saturday midday peak hours. SW Martinazzi Avenue/SW Sagert Street and SW 65th Avenue/SW Sagert Street intersections currently operate at LOS F. The proposal will have an insignificant effect on either of these intersections. The project will result in a less than 1.5 percent increase in traffic at either intersection.

SECTION 11.640 PEDESTRIAN PLAN.

- (1) Providing a connected network of pedestrian facilities is important for:
- (a) serving shorter pedestrian trips from neighborhoods to area activity centers, such as schools, churches, and neighborhood commercial uses;
 - (b) providing access to public transit;
 - (c) meeting residents' recreational needs; and
 - (d) providing circulation within the Tualatin Town Center.

Response: The proposed pedestrian plan at Nyberg Rivers provides connectivity to and through the site to the Tualatin Town Center and other regional trail networks along the Tualatin River Trail and the Ice Age Tonquin Trail located west of the Tualatin Town Center. The pedestrian paths on-site also connect to the existing Tri-Met bus stop located along Martinazzi Avenue. A series of sidewalks and pathways will provide direct connections throughout the site and integrate into the City's existing and planned pedestrian network. The Master Plan document included with this narrative (Exhibit A) does include Cross Sections "A-A, B-B, and C-C" to provide an elevation level graphic of the proposed street sections and shared path accessways across the main drive aisles of the site.

- (2) The City's street standards call for sidewalks to be provided along all new streets. As development and redevelopment occurs, and as City funding permits, gaps in the existing sidewalk system will be filled. The Tualatin Pedestrian Plan, depicted in Figure 11-4, identifies the sections of the City's arterial and collector system where gaps currently exist.

Response: The proposed shared facility drive-aisles shown through Nyberg Rivers feature sidewalks on both sides of the street. Figure 11-4 does show a multi-use path on the west side of I-5, as well as the Tualatin River path. Based on the legend shown on Figure 11-4, the portion of Nyberg Street that fronts Nyberg Rivers does provide sidewalks to meet the standard. The proposed internal "Loop Road" driveway does provide a shared path network. As shown in the Master Plan document, included as Exhibit A with this application, drive aisle cross-sections (A-A, B-B, and C-C) shown on the Transportation Plan demonstrate the proposed improvements for the site.

- (3) The need to develop a recreational pathway and trail system carries forward into this TSP. Although transportation funding constraints do not allow the

development of this system through TSP projects, the City may wish to consider alternative funding sources, such as parks and recreation bonds or SDCs. Of particular interest are a multi-use path along the south bank of the Tualatin River, and future pedestrian and bicycle bridges across the Tualatin River along the SW 65th, SW 108th, and the Hall Boulevard connection alignments. The future locations of these facilities are shown in Figure 11-4.

Response: Figure 11-4 shows multi-use paths on both the eastern portion of the Nyberg Rivers property, as well as a trail along the south side of the Tualatin River. The Applicant is providing a shared pathway easement within the proposed conservation area in order to create a future path along the Tualatin River. The approximate location of the shared pathway easement is shown on the Site Plan enclosed with this application.

SECTION 11.650 BICYCLE PLAN.

The bicycle plan establishes a network of bicycle lanes and routes that connect the City's bicycle trip generators to provide a safe, interconnected bicycle system. Bicycle lanes are designated on arterial and collector street segments with anticipated future volumes of over 3,000 daily vehicles. Bicycle routes, where bicyclists share a lane with other vehicles, are designated on other lower-volume collector streets, and certain local streets that provide connectivity within neighborhoods or to future multi-use recreation paths.

Figure 11-5 shows the City's bicycle plan. As portions of the City's streets are widened, either through adjacent development or a public works projects, bicycle lanes will be provided where indicated on the plan. [Ord. 1103-02, 3/25/2002]

Response: Figure 11-5 shows multi-use paths on both the eastern portion of the Nyberg Rivers property, as well as a trail along the south side of the Tualatin River. The Applicant is providing a shared pathway easement within the proposed natural area in order to create a future path along the Tualatin River. The shared pathway easement is shown on the Site Plan enclosed with this application. Also, Figure 11-5 does show the Loop Road as a road with bike lanes. The applicant is proposing a shared-facility driveway to accommodate vehicles and bicycles, as well as a curb tight sidewalk to accompany the sidewalk. The Nyberg Rivers Master Plan—Pedestrian & Bicycle Plan, included under Exhibit A with this application, displays the proposed networks as well as sample cross-sections of those transportation elements.

SECTION 11.660 TRANSIT PLAN.

- (1) Although the City of Tualatin does not provide public transportation services, it can provide policies and facilities that support the provision and usage of transit service. This section outlines the steps Tualatin plans to take to support increased transit usage, as part of its efforts to work towards Metro's 2040 mode split targets. It must be recognized that in order for these targets to be met, the

region must provide greater support for increased local transit service than provided for in the financially con-strained RTP.

(a) Transit Streets

Figure 11-6 depicts the streets that are designated as transit streets: streets that are expected to have fixed-route transit service operating along them at some point prior to 2020. Transit streets generally provide a wider-than-normal sidewalk width, as shown in Tualatin's recommended Street Design Standards (TDC Chapter 75). The City should provide notice to Tri-Met of development applications adjacent to existing Tri-Met stops or at intersections located along future transit streets. The City's development standards may allow the conditioning of the following transit-related improvements of such developments, upon request by Tri-Met:

Response: The Tualatin transit plan reflected on Figure 11-6 shows a transit street and major transit stop located along SW Martinazzi Blvd. Public transit users accessing Master Plan area can catch the bus at this bus stop and proceed to the commercial center via a the planned pedestrian and bicycle connections proposed throughout the site.

SECTION 11.730 IMPLEMENTATION PLAN.

(1) TSP Implementation Steps

This chapter outlines specific transportation system improvement policies and recommendations that are required to address the City of Tualatin's long-term transportation needs and to comply with applicable state and regional plans, laws, and rules. This section lists the specific projects that form the TSP's financially constrained capital project plan, and also lists un-funded projects that are required to fully address all of the transportation needs identified through the TSP planning process. New sources of funding, and/or increasing the revenue available from existing funding sources, will be required to meet all of the City's transportation needs.

This TSP will be implemented in two ways. First, the policies set forth in this document will be developed into code language that will be adopted into Tualatin's Community Development Code, and the TSP itself will be adopted as the transportation element of the City's comprehensive plan. Second, the projects contained in the TSP's list will be used to guide the City's annual capital improvement planning efforts.

The sequencing plan presented in the TSP is not detailed to the point of a schedule identifying specific years when infra-structure should be constructed, but rather ranks projects to be developed within near-term (0-5 years) and longer-term (6-10 and 11-20 years) horizon periods and by dollar value. In this manner, the implementation of identified system improvements has been staged to spread investment in the City's transportation infrastructure over the 20-year life of the plan. The City will need to periodically update its TSP, and will review the need and timing for longer-term improvements at those times. Prioritizing specific near-term projects will occur annually when the City updates its five-year financial plan and prepares its capital improvement plan for the following year. Future road improvements or related transportation projects listed or not listed in this chapter are not required to be reviewed and approved through a land use process.

The construction of roads, storm drainage, water, sewer, and electrical facilities in conjunction with local development activity should be coordinated if the City of Tualatin is to continue to develop in an orderly and efficient way. Consequently, the plans proposed in the TSP should be considered in light of developing infrastructure sequencing plans, and may need to be modified accordingly.

Response: The Applicant is aware of the TSP implementation steps. There is several financially constrained capital projects located within the vicinity of the Nyberg Rivers Master Plan. The proposed improvements to the transportation system result in a net benefit overall to the transportation system that serves the Master Plan area. More detail concerning the proposed improvements and the transportation system are contained within the Traffic Impact Analysis provided by Kittelson and associates attached hereto.

(2) Financially Constrained Capital Project Summary

The projects listed in Table 11-3 reflect the trade-offs made by the City between addressing transportation needs identified through the TSP process and the financial constraints faced by the City. These projects do not address all of the City's needs, but represent the most important projects that the City can reasonably expect to fund over the next 20 years, under the assumption of no new transportation revenue during that time.

The table is organized into four groups: short-term (0-5 years), mid-term (6-10 years), and long-term (11-20 years) projects, with an additional group of projects that will likely be funded when development occurs that triggers the need for that project. Each project is listed with a location, a short project description, the transportation modes served by the project, the project purpose, the project's estimated cost, and the anticipated funding source. Cost estimates reflect 2001 dollars, are un-adjusted for inflation, and generally were developed by the RTP or City staff through prior transportation planning efforts.

Figure 11-8a, b, c, d illustrates the project locations. Each project is described briefly afterwards. The projects that could affect rivers, streams and wetlands have not been analyzed in terms of Statewide Planning Goal 5 (natural resources) as required by Oregon Administrative Rule 660-12-0025(2) and (3)(b). Thus, prior to construction a Goal 5 analysis will be completed.

- (d) **Boones Ferry Road Widening (Table 11-3, No. 4)**
Boones Ferry Road should be widened to three lanes with turn lanes from Martinazzi Avenue to Tualatin-Sherwood Road. Pedestrian facilities should be completed and bicycle lanes widened or constructed. Turn lanes at the Martinazzi Avenue intersection should be lengthened to provide more storage, and the Tualatin Road signal should be upgraded.
- (e) **Nyberg/I-5 Interchange (#289) Improvements (Table 11-3, No. 5)**
As one of only two major access points from I-5 to Tualatin, the Nyberg Road/I-5 interchange is forced to accommodate the majority of traffic traveling in and out of Tualatin. Consequently, the interchange experiences periods of major congestion, both on the I-5 southbound off-ramp and the Nyberg Road approaches. This project increases the interchange's capacity by adding a second left-turn lane to the southbound off-ramp, and

widens the over-crossing to accommodate an additional lane in each direction.

- (o) **Boones Ferry Road, Martinazzi Avenue Access Management (Table 11-3, No. 15)**
To reduce delay, and improve roadway capacity and safety, driveways along Boones Ferry Road and Martinazzi Avenue previously identified by the City Engineer should be restricted to right-in, right-out movements.
- (p) **Town Center Refinement Plan (Table 11-3, No. 16)**
Addresses transportation system needs associated with development in the Town Center Design Type, or portions thereof.

Response: There are four (4) financially constrained capital projects located within the vicinity of the Nyberg Rivers Master Plan. The Boones Ferry Road Widening (#4), the Nyberg/I-5 Interchange Improvements(#5), the Boones Ferry Road/Martinazzi Avenue Access Management (#15) and the Town Center Refinement Plan (#16) are all slated for completion in the next 0-5 years. The Nyberg Street right-turn lane and bicycle lane addition, as well as the Seneca Street and Street 'A' public improvements will be weighted as a proportionate share to the capital projects budget. The applicant requests credit for these potential public improvements that may be offset as credits against TDT charges.

- (3) **Priority Project Summary**
Table 11-4 identifies additional projects required to fully address the City's long-term transportation needs, but for which no current funding sources have been identified. In some cases, potential alternative funding sources have been identified. Should future transportation funding increase above the levels assumed in this TSP, this list can be used as a starting point to prioritize additional projects. Some projects on this list may also be appropriate for development-based funding, depending on the relationship of the development's transportation impacts to the project. Figure 11-9 presents the Priority System TSP Projects. Table 11-4 does not specifically list a project for every segment of every street. It is the intent of this subsection and Table 11-4 to indicate that all segments of streets designated E, D, C and B-CI on Figure 11-1 are on a project for future construction and are permitted outright in each Planning District. The projects that could affect rivers, streams and wetlands have not been analyzed in terms of Statewide Planning Goal 5 (Natural Resources) as required by Oregon Administrative Rule 660-12-0025(2) and (3)(b). Thus, prior to construction a Goal 5 analysis will be completed.

Response: The priority project summary summarized in Table 11-4 does include several unfunded projects within the general Nyberg Rivers area. The list includes the following projects:

- Tualatin River pathway-- \$2.5 million
- Nyberg Street: bike lanes from Tualatin-Sherwood to SW 65th Ave-- \$850,000

- Central design district pedestrian street enhancements-- \$2.6 million
- Nyberg Road: widen to 7 lanes, Martinazzi to I-5-- \$700,000
- Loop Road: extend Seneca St east of Martinazzi then north between City offices, then east behind K-Mart. A connection to Boones Ferry Rd may be appropriate on the north side of City offices. \$2.5 million

The proposed internal Loop Road is identified as a priority project with a concept for its location on the site. The applicant is constructing the Loop Road connection through the site that will provide connectivity to Seneca Street as well as Street 'A' to provide access onto Boones Ferry Road. These two privately-funded public improvements will work to improve the City's long-term transportation needs. .

(4) Traffic Signal Plan

Figure 11-10 shows Tualatin's proposed future traffic signals. This list represents those traffic signals that have been identified as part of the Tualatin TSP. Due to the potential for shifting or unanticipated development, other traffic signal locations may be added based on the findings from a detailed traffic operations and safety analysis. [Ord. 1103-02, 3/25/02; Ord. 1321-11 §16, 4/25/11]

Response: Figure 11-10 shows a proposed traffic signal located at the Seneca Street and Martinazzi Blvd intersection. Based on the TIA provided by Kittelson, a traffic signal at the Seneca/Martinazzi intersection is a proposed transportation improvement associated with the Nyberg Rivers Master Plan.

TDC 30: TUALATIN URBAN RENEWAL PLAN

SECTION 30.010 URBAN RENEWAL PLAN.

The Tualatin Urban Renewal Plan, 1975, as amended by the Tualatin Central Urban Renewal Plan, 1984, 1987, 1992, 2002, 2006, and 2009 and thereafter referred to as the "Tualatin Central Urban Renewal Plan," is hereby adopted as part of the Tualatin Community Plan and is incorporated by reference into the Tualatin Development Code. [Ord. 730-87, §3, 9/14/87; Ord. 881-92, §3, 11/9/92; Ord. 882-92, §3, 12/14/92; Ord. 1108-02, 4/22/02; Ord. 1213-06, 7/10/06; Ord. 1290-09 §1, 10/12/09]

Response: Nyberg Rivers is included as a part of the Central Urban Renewal Area, although it is outside the Core Area Parking District shown on Map 9-3. This map also shows the land use blocks within the Central Urban Renewal Area. Nyberg Rivers encompasses land within Blocks 1 through 5.

SECTION 31.063 NEIGHBORHOOD/ DEVELOPER MEETINGS.

- (1) This section applies to the following types of Land Use applications: Annexations; Architectural Reviews, except Level I (Clear and Objective) Single-family Architectural Review; Conditional Uses; Historic Landmark actions, including designation, removal of designation, demolition, relocation, or alteration or new construction: Industrial Master Plans; Partitions; Plan Map Amendments for a specific property; Plan Text Amendments for a specific property; Subdivisions; Tree Removal Permit; Transitional Use Permit; and Variances, except for variances to existing single family residences.
- (2) Prior to the submittal of an application listed in [TDC 31.063\(1\)](#) and following a pre-application meeting held with the City, the developer shall host a meeting for the surrounding property owners located within the mailing area designated in TDC 31.064(1)(c). Notice of the meeting shall be provided to Recognized Neighborhood Associations within the Notice Area of [TDC 31.064\(1\)\(c\)](#) and to designated representatives of recognized Citizen Involvement Organizations. The purpose of this meeting is to provide a means for the applicant and surrounding property owners to meet to review a development proposal and identify issues regarding the proposal so they can be considered prior to the application submittal. The meeting is intended to allow the developer and neighbors to share information and concerns regarding the project. The applicant may consider whether to incorporate solutions to these issues prior to application submittal.
- (3) The Neighborhood/Developer Meeting shall be held on a weekday evening, or weekend no earlier than 10:00 a.m. and no later than 6:00 p.m., at a location within the City of Tualatin.
- (4) The applicant shall at least 14 calendar days and no more than 28 calendar days prior to the meeting mail notice of the meeting pursuant to [TDC 31.064\(1\)](#) stating the date, time and location of the meeting and briefly discussing the nature and location of the proposal:
- (5) Failure of a property owner to receive notice shall not invalidate the Neighborhood/Developer Meeting proceedings.

- (6) The applicant shall, at least 14 calendar days before the meeting, post a sign pursuant to [TDC 31.064\(2\)](#). If the sign disappears prior to the meeting date, the applicant shall replace it within forty-eight (48) hours. The applicant shall remove the sign no later than fourteen (14) days after the meeting date.
- (7) The applicant shall prepare meeting notes identifying the persons attending and the major points that were discussed and expressed.
- (8) The applicant is required to hold one meeting prior to submitting an application for a specific site, but may hold additional meetings if desired.
- (9) If an applicant fails to hold a neighborhood meeting, the application shall be deemed incomplete.
- (10) The application shall include the following materials related to the Neighborhood/Developer meeting:
 - (a) the mailing list for the notice;
 - (b) a copy of the notice;
 - (c) an affidavit of the mailing and posting;
 - (d) the original sign-in sheet of participants;
 - (e) the meeting notes described in [TDC 31.063\(7\)](#).
- (11) Applications shall be submitted to the City within 180 days of the Neighborhood/Developer meeting. If an application is not submitted in this time frame, the Developer shall be required to hold a new Neighborhood/Developer meeting. [Ord. 1149-03, 10/13/03; Ord. 1260-08 §1, 05/12/08; Ord. 1304-10 §2, 05/14/10; Ord. 1338-12 §2, 01/23/12]

Response: The proposed Master Plan and Conditional Use submittal is subject to a Neighborhood/Developer Meeting. A Neighborhood/Developer Meeting was held on March 20, 2013 at the Umpqua Bank branch in Tualatin, adjacent to the project site. The meeting was held from 5-7 p.m. and all property owners located within the mailing area were invited, as well as all CIO representatives. The Applicant and the applicant's representatives were present at the meeting to field any questions and solicit public comment for the proposed redevelopment at Nyberg Rivers. A letter with notice of the meeting was mailed to property owners at least 14 calendar days prior to the meeting and four (4) public notice signs were posted on site at least 14 calendar days before the meeting. Affidavits of posting and signed acknowledgements are included with this application. Also, the mailing list, a copy of the notice, the original sign-in sheet for the Neighborhood Meeting, as well as meeting notes are included with this application.

SECTION 31.064 LAND USE APPLICATIONS.

This section applies to the following types of Land Use applications: Annexations; Architectural Reviews, except Level I (Clear and Objective) Single-family Architectural

Review; Conditional Uses; Historic Landmark actions, including designation, removal of designation, demolition, relocation, or alteration or new construction; Industrial Master Plans; Partitions; Plan Map Amendments for a specific property; Plan Text Amendments for a specific property; Subdivisions; Tree Removal Permit; Transitional Use Permit; and Variances, except for variances to existing single family residences.

- (1) **Mail:** An applicant shall mail notice of a Neighborhood/Developer Meeting and the City shall mail notice of application submittal as follows:
 - (a) **Recipients:** The mailing recipients shall be the applicant, the owners of the subject property, owners of property within the Mailing Area of [TDC 31.064\(1\)\(c\)](#) recognized neighborhood associations as defined in [TDC 31.060](#) recognized through [TDC 31.065](#) and within the Mailing Area of [TDC 31.064\(1\)\(c\)](#), and designated representatives of recognized Citizen Involvement Organizations as established in [TMC Chapter 11-9](#).
 - (b) **Recipient Identification:** The City shall use the names and addresses of the owner or owners of record as shown in the current, or within thirty (30) days of a completed application, computer roll of the County Assessor. The applicant shall be responsible for having one of the following prepare the list: a land title company; a land use planning consultant authorized by the State of Oregon to conduct business in the state; a registered architect, landscape architect, engineer, surveyor, or attorney; or where the City is the applicant, the Community Development Director or when applicable the City Engineer. The applicant shall update the list of property owners no less than every ninety (90) days until a final land use decision is rendered. The applicant shall provide a copy of the list of recipients and their current mailing addresses as part of the land use application.
 - (c) **Mailing Area, Buffer, or Distance:** The mailing area shall extend 1,000 feet from the boundaries of the subject property. If the 1,000-foot area includes lots within a platted residential subdivision, the notice area shall extend to include the entire subdivision of which the lots are part, and the applicant shall identify these subdivisions for staff as part of the mailing notification list. If the residential subdivision is one of two or more individually platted phases sharing a single subdivision name, the notice area need not include the additional phases.
 - (d) **ARB:** The notice of application submittal for an Architectural Review application subject to review by the Architectural Review Board (ARB) shall have the minimum information pursuant to [TDC 31.074\(3\)](#).
- (2) **Sign Posting:** The applicant shall as follows both provide and post on the subject property a sign that conforms to the standard design established by the City for signs notifying the public of land use actions:
 - (a) **Minimum Design Requirements:** The sign shall be waterproof, and the face size shall be eighteen (18) by twenty-four (24) inches (18 x 24) with text being at least two (2) inches tall.

- (b) **On-site Placement:** Prior to land use application submittal, the applicant shall place a sign along the public street frontage of the subject property or, if there is no public street frontage, along the public right-of-way (ROW) of the street nearest the subject property. A subject property having more than one public street frontage shall have at least one posted sign per frontage with each frontage having one sign.

For a subject property that has a single frontage that is along a dead-end street, the applicant shall post an additional sign along the public ROW of the nearest through street. The applicant shall not place the sign within public ROW pursuant to TDC 38.100(1); however, for a subject property that has no public street frontage or that has a single frontage that is along a dead-end street, the applicant may place the sign within public ROW of the nearest street.

- (c) **Proof of Posting:** The applicant shall submit as part of the land use application submittal an affidavit of posting to the Community Development Director or when applicable the City Engineer.
- (d) **Removal:** If the sign disappears prior to the final decision date of the subject land use application, the applicant shall replace it within forty-eight (48) hours. The applicant shall remove the sign no later than fourteen (14) days after the City makes a final decision on the subject land use application. [Ord. 1304-10 §29, 05/14/10; Ord. 1338-12 §4, 01/23/12]

Response: The proposed Master Plan submittal is subject to the mailing and posting requirements prior to a Neighborhood/Developer Meeting. A Neighborhood/Developer Meeting was held on March 20, 2013 at the Umpqua Bank branch in Tualatin, adjacent to the project site. A letter and site plan was mailed to owners within 1,000 feet from the boundaries of the subject property. That letter was mailed on March 4th, 2013 to a list of property owners provided by the City of Tualatin Community Development Department. That list is included as an exhibit with this submittal.

Four (4) public notice signs were posted on-site on March 6, 2013. A signed affidavit of public notice posting is included with this application, along with a photo sheet showing the posting locations of the four (4) signs. These signs were designed according to the sign template provided by the City and the sign was printed on an 18 x 24" board with colors as provided on the City template.

SECTION 31.077 QUASI-JUDICIAL EVIDENTIARY HEARING PROCEDURES.

- (1) A hearing under these procedures provides a forum to apply standards to a specific set of facts to determine whether the facts conform to the applicable criteria and the resulting determination will directly affect only a small number of identifiable persons. Except as otherwise provided, the procedures set out in this section shall be followed when the subject matter of the evidentiary hearing would result in a quasi-judicial decision, including, but not limited to an annexation to the City Limits pursuant to [TDC 31.067](#), an interpretation of a Code provision pursuant to [TDC 31.070](#), a conditional use application ([TDC Chapter 32](#)), a variance or minor variance application ([TDC Chapter 33](#)), a transitional use application ([TDC 34.180-34.186](#)), a conditional use permit for a small lot

subdivision application ([TDC 40.030\(3\)](#), [41.030\(2\)](#)), a nonconforming use, or reinstatement of a nonconforming use application ([TDC Chapter 35](#)), a quasi-judicial amendment to the Tualatin Community Plan or Map, a decision by staff whether or not to extend approval of an Architectural Review decision, a request for review of a final decision by the City staff on a partition, subdivision, property line adjustment with a minor variance, arterial access decision or the Utility Facility portion of an Architectural Review, or a re-request for review of a decision of the Architectural Review Board on an Architectural Review Plan.

Response: The Nyberg Woods Master Plan and Conditional Use application is subject to a Quasi-Judicial decision, based on the fact that this proposed redevelopment includes a master plan application and conditional use review. The applicant is aware of the procedures applicable to a quasi-judicial decision and will work with the City to address the noticing requirements. The applicant is also aware of the public hearing procedures and the process for the hearing body to render a decision.

TDC 32: CONDITIONAL USES

PROPOSED USES REQUIRING CONDITIONAL USE REVIEW AND APPROVAL

A conditional use permit application is filed with this master plan application as a request to allow specific uses within the CC and CO planning districts. Based on the permitted and conditional uses summarized in both the Central Urban Renewal Plan and the Tualatin Development Code (Chapters 50 and 53, specifically) the following uses are subject to conditional uses as determined by use type and location within the planning districts:

TDC 50.030 CENTRAL URBAN RENEWAL PLAN – ADDITIONAL PERMITTED USES AND CONDITIONAL USES.

In the Central Urban Renewal District, additional uses are permitted only on the blocks listed below, as shown on [Map 9-3](#).

- (1) Uses permitted in the RH District on Block 1.
- (2) Uses permitted in the CC District as a Conditional Use on Block 1.

SECTION 53.050 CONDITIONAL USES.

The following uses are permitted when authorized in accordance with [TDC Chapter 32](#), and provided retail uses on land designated Employment Area, Corridor or Industrial Area on [Map 9-4](#) shall not be greater than 60,000 square feet of gross floor area per building or business.

- (5) Outside storage or sales.

As detailed above, the following uses would be subject to conditional use review and permitting.

- **Portion of Building 1040**— This building is a sporting goods store with outdoor storage and sales. The portion of the building that is located in the CC district is a permitted use. The portion of the building that is located in the CO district is also permitted but subject to the conditional use criteria of Chapter 32. (See Urban Renewal Plan, Permitted and Conditional Uses for Block1 at page 34-35 and TDC 50.030(2)).
- **Building 1040—Outside Sales:** the proposed sporting goods store requires outdoor sales and storage area. Under TDC 53.050(5), outside storage or sales is subject to CUP review in the CC District. The outdoor storage and sales is located in the CC District.

The following code sections outline the specific provision, followed by a narrative response demonstrating how the applicant proposes to address the specific conditional use criteria.

SECTION 32.010 PURPOSE AND INTENT.

It is the intent of this chapter to provide a set of procedures and standards for conditional uses of land or structures which, because of their unique characteristics

relative to locational features, design, size, operation, circulation and public interest or service, require special consideration in relation to the welfare of adjacent properties and the community as a whole. It is the purpose of the regulations and standards set forth below to:

- (1) Allow, on one hand, practical latitude for utilization of land and structures, but at the same time maintain adequate provision for the protection of the health, safety, convenience and general welfare of the community and adjacent properties; and
- (2) Provide machinery for periodic re-view of conditional use permits to provide for further conditions to more adequately assure conformity of such uses to the public welfare. [Ord. 743-88, 3/28/88]

Response: Portions of the Nyberg Rivers redevelopment proposal are subject to a conditional use review and decision. The proposed sporting goods store located in Building 1040 is subject to a conditional use for two facets—1) the building overlaps into a portion of the CO district, where permitted CC uses are subject to CUP review and 2) the store requires an option for permanent outdoor sales along the building frontage.

SECTION 32.020 SITING CRITERIA.

The provisions of this chapter are signed to provide siting criteria for the conditional uses specified herein and guidelines for the imposition of additional conditions not specifically provided for herein, to the end that such uses will:

- (1) Be consistent with the intent and purpose of the planning district in which it is proposed to locate such use, meet the requirements of the Tualatin Community Plan with regard to providing benefit to the general welfare of the public, and fill a probable need of the public which can best be met by a conditional use at this time and in this place.
- (2) Comply with the requirements of the planning district within which the conditional use is proposed and in accordance with conditions attached to such use under the authority of this chapter. [Ord. 743-88, 3/28/88]

Response: The proposed sporting goods store located in Building 1040 is an outright permitted use in the CC zone and also a permitted use subject to Chapter 32 in the CO zone within Block 1 of the Urban Renewal Plan. The conditional use elements of this building represents only 21- percent of the overall building mass yet are required to meet the needs of the retailer. Because the majority of the use is permitted outright and a smaller element of the use is specifically contemplated by the Urban Renewal Plan, the intent and purpose of both the CC and CO planning districts will be achieved, while also meeting the requirements of the Tualatin Community Plan. This narrative includes responses to those applicable sections to show compliance with those standards.

SECTION 32.030 CRITERIA FOR REVIEW OF CONDITIONAL USES.

The City Council may allow a conditional use, after a hearing conducted pursuant to [TDC 32.070](#), provided that the applicant provides evidence substantiating that all the requirements of this Code relative to the proposed use are satisfied, and further provided

that the applicant demonstrates that the proposed use also satisfies the following criteria:

(1) The use is listed as a conditional use in the underlying planning district.

Response: The 23,513 SF portion of the 110,000 square foot retail store is located in the CO District. Under 50.030(2), all uses permitted in the CC District are allowed as conditional uses in the CO District. Thus, the portion of the store in the CO District is listed as a conditional use in the underlying zoning district. The outdoor storage and sales are listed as a conditional uses in the CC District under 53.050 (5) in compliance with this criteria.

(2) The characteristics of the site are suitable for the proposed use, considering size, shape, location, topography, existence of improvements and natural features.

Response: The conditional use is proposed to be developed within an existing retail center. The site is already committed to large format retail with a mix of smaller and medium sized complementary commercial uses. The site is zoned CC and CO and allows and encourages the kinds of uses contemplated here. The Urban Renewal Plan further encourages redevelopment of this site with a denser mix of commercial uses to meet the redevelopment and economic development objectives of that Plan as discussed earlier in this application. The site size and shape allow an efficient layout of the uses with adequate parking and a well-designed landscape plan. Site topography is relatively flat with no steep grades. The location of the site is adjacent to the City's downtown and adjacent the I-5 corridor along Nyberg Street, a corridor already committed to large format retail development and designed to accommodate commercial uses. As detailed above and incorporated herein by reference, the transportation system can safely accommodate the use and the development of the site will include several improvements to public facilities that will improve bicycle, pedestrian and vehicle movements in the area. The Tualatin River runs to the north of the site and will not be negatively impacted. In fact, the site development includes a dedication of a trail easement along the river for future development. Therefore, the characteristics of the site are suitable for the proposed use.

(3) The proposed development is timely, considering the adequacy of transportation systems, public facilities, and services existing or planned for the area affected by the use.

Response: The findings above under the Master Plan and Urban Renewal Plan address the transportation facilities in the area and cite to the TIA completed for the proposed project. The scope of the TIA was first approved by Washington County and the City. The Applicant then conducted the analysis consistent with this scoping agreement. The analysis demonstrates that all study intersections will continue to operate at acceptable levels of service and that the development is timely considering the adequacy of transportation services. This conditional use request pertains to only [square 23,513 SF of the sporting goods store and the outdoor storage and sales. These uses represent a small fraction of the uses identified in the TIA. Because the entire site and its associated density are consistent with the timely delivery of transportation facilities, so too is a small portion of that square footage subject to this conditional use request.

As discussed above, and incorporated herein by reference, the Applicant has proposed to complete the required infrastructure improvements to the water, sanitary sewer and stormwater systems that service the site. The proposed large format retail store is consistent with this requirement.

- (4) **The proposed use will not alter the character of the surrounding area in any manner that substantially limits, impairs, or precludes the use of surrounding properties for the primary uses listed in the underlying planning district.**

Response: The character of the area is defined by its existing and surrounding uses. The site itself is currently developed with a retail center. This application will permit the redevelopment of that center with a well-designed site plan, landscape plan and architectural elevations. New commercial uses will replace old commercial uses. Vacant and undesirable uses will be removed and replaced with a more family-friendly and active center. The Site Plan as proposed reflects the uses allowed in the underlying zoning district and contemplated in the Urban Renewal Plan. The transportation, pedestrian and bicycle network will be improved with this development, not only serving the subject site but contributing to greater circulation options for surrounding properties. In particular, the new loop road through the site will make the new connection between Boones Ferry, Seneca and Nyberg streets and the improvements along Nyberg will facilitate better traffic movements along the perimeter. The surrounding properties are also zoned for like uses. The redevelopment of this site will complement and perhaps encourage future redevelopment on other surrounding parcels as more people are drawn to the downtown core by these economic redevelopment projects. The proposed use will not therefore alter the character of the surrounding area in a way that impairs, precludes or limits. Rather, redevelopment of this underutilized site in the Central Urban Renewal Area will more likely encourage similar redevelopment opportunities consistent with the underlying planning districts.

- (5) **The proposal satisfies those objectives and policies of the Tualatin Community Plan that are applicable to the proposed use. [Ord. 743-88, 3/28/88]**

Response: All of the objectives and policies of the Tualatin Community Plan are addressed above. The application has demonstrated that the Tualatin Community Plan calls for the development of this site with Central Commercial and Office Commercial uses in the manner proposed here. The Plan calls for redevelopment of this site consistent with the Central Urban Renewal Plan which includes policies for the redevelopment of this site with commercial uses. The transportation elements of the Plan are satisfied by the TIA completed for this site demonstrating that the transportation facilities are adequate to serve the development and the site has been sensitively designed to accommodate future uses on neighboring parcels.

SECTION 32.040 AUTHORITY AND CITY COUNCIL ACTION.

The City Council may approve, approve with conditions, or deny the application for a conditional use permit. In permitting a conditional use, the City Council may impose, in addition to the regulations and standards expressly specified in this chapter, other conditions found necessary to protect the best interests of the surrounding property or neighborhood or the City as a whole. The conditions may include requirements increasing the required lot size or yard dimensions, controlling the location and number

of vehicular access points to the property, increasing street width, requiring dedication and improvement of additional right-of-way, increasing the number of off-street parking or loading spaces required, limiting the coverage or height of buildings because of obstruction of view or reduction of light or air to adjacent property, limiting the hours of operation, requiring sight obscuring fencing and landscaping, requiring construction of sound barriers such as earth berms or masonry walls, allowing co-location of antenna systems or platforms on a wireless communication support structure, requiring monopole design for wireless communication support structures, specifying the type of architectural treatment for wireless communication support structures to be compatible with its surrounding, requiring that obsolete or unused wireless communication support structures and associated equipment and antennas be re-moved within 12 months of cessation of operations at a site, and requiring any future enlargement or alteration of the use to be reviewed by the City Council. The City Council may also require a review of the conditional use by the City Council on or before a specified date and may upon such review impose further conditions consistent with this Chapter. In no event shall this Chapter be used as a means to exclude multi-family housing from the City. [Ord. 812-90, §2, 9/24/90; Ord. 864-92, §4, 4/13/92; Ord. 965-96, §5, 12/9/96]

Response: The Applicant is aware of the authority and decision making methodology employed by the City Council. The applicant's representative will work with the City to provide timely and sufficient information for the Council to make an informed decision.

SECTION 32.050 AUTHORITY OF ARCHITECTURAL REVIEW BOARD TO IMPOSE CONDITIONS.

In those cases where the proposed conditional use must be approved by the Architectural Review Board under applicable provisions of the Community Development Code, the Architectural Review Board may attach conditions to such conditional uses of land in addition to those conditions imposed by the City Council. Such additional conditions may include, but shall not be limited to, setback requirements, screening, off-street parking and loading, construction standards and maintenance. All such additional conditions may be imposed if it is found by the Architectural Review Board that they are necessary to provide for or protect public health, safety or general welfare, and that such conditions are consistent with the purpose and intent of this chapter. [Ord. 743-88, 3/28/88]

Response: Pending approval of this master plan and conditional use permit, Nyberg Rivers is subject to Architectural Review. This application requests approval of all elements of the site plan subject to conditional use and master plan review.

SECTION 32.060 APPLICATION FOR CONDITIONAL USE.

A request for a conditional use, modification of an existing conditional use permit, or a review of an existing conditional use permit shall be initiated by a property owner or the owner's authorized agent by filing an application with the Community Development Department. The applicant shall discuss the proposed use and site plans with the Community Development Director and City Engineer in a pre-application conference prior to submitting an application. An applicant for a Conditional Use shall conduct a Neighborhood/Developer Meeting subject to [TDC 31.063](#). Following the pre-application conference and Neighborhood/Developer Meeting, the applicant shall submit an

application including, but not limited to, the following: project title; the names, addresses, and telephone numbers of the property owners and applicants, and when applicable, the architect, landscape architect and engineer; the signatures of the property owners and applicants; the site address and the assessor's tax map and tax lot numbers; a site plan, drawn to scale, showing the dimensions and arrangement of the proposed development, the information on the Neighborhood/Developer Meeting specified in [TDC 31.063\(10\)](#), a Service Provider Letter from Clean Water Services (CWS) indicating that a "Stormwater Connection Permit Authorization Letter" will likely be issued; and a list of mailing recipients pursuant to [TDC 31.064\(1\)](#). The application shall be accompanied by a fee as established by City Council resolution. If a railroad-highway grade crossing provides or will provide the only access to the subject property, the applicant must indicate that fact in the application and the City must notify the ODOT Rail Division and the railroad company that the application has been received. The applicant shall post a sign pursuant to [TDC 31.064\(2\)](#) [Ord. 715-87, §7, 2/23/87; Ord. 933-94, §10, 11/28/94; Ord. 1070-01 §4, 04/9/01; Ord. 1157-04, 3/8/04; Ord. 1149-03; 10/13/03; Ord. 1304-10 §9, 6/14/10]

Response: The request was initiated by the property owner and the owner's representative. A signed application with the required signatures is proof that the conditional use application is requested by the property owner. A pre-application and Neighborhood/Developer Meeting have been held and this narrative is a part of the formal request for conditional use review and approval.

SECTION 32.070 PUBLIC HEARING FOR A CONDITIONAL USE.

Before acting on a request for a conditional use permit, a proposed conditional use shall be considered by the City Council at a public hearing conducted in the manner provided for in [TDC 31.077](#). The City Council may recess a hearing on a request for a conditional use permit in order to obtain additional information or serve further notices upon property owners or persons who it decides may be interested in or affected by the proposed conditional use. Upon recessing for this purpose, the Council shall announce the time, place and date when the hearing will be resumed. [Ord. 743-88, § 21, 3/28/88]

Response: The Applicant is aware that the requested conditional use is subject to a public hearing before a decision is rendered.

SECTION 32.080 REVOCATION OF CONDITIONAL USE PERMIT.

- (1) Any previously granted conditional use permit may be revoked by the City Council, after a hearing conducted in the manner required for approval of a conditional use permit initially, upon the following grounds:
 - (a) Failure to comply with the conditions of approval.
 - (b) Discontinuance of the use for a period in excess of two years.
 - (c) Failure to comply with other applicable provisions of the Tualatin Community Plan regarding design, dimensional or use requirements.

- (d) A change in the Tualatin Community Plan or Planning District Standards of the planning district within which the use is located that have the effect of no longer allowing a new conditional use permit application to be considered in such planning district.
- (2) Revocations initiated under TDC 32.080(1)(a) or (b) above shall not be initiated for at least 6 months after approval of the conditional use permit. Revocations initiated under TDC 32.080(1)(a), (b) and (c) above shall have the effect of making the previously granted conditional use permit void until a new application is submitted and granted. Revocations initiated under TDC 32.080(d) above shall have the effect of making the previously granted conditional use a nonconforming use. [Ord. 743-88, 3/28/88; Ord. 1333-11 §1, 9/12/11]

Response: The Applicant is aware of the revocation of a conditional use permit provision. There are no existing conditional uses permitted on-site at Nyberg Rivers.

SECTION 32.090 AUTOMATIC TERMINATION OF CONDITIONAL USE.

- (1) Unless otherwise provided by the Council in the resolution granting approval of the conditional use permit, a conditional use permit shall automatically become null and void two years after the effective date upon which it was granted unless one of the following events occur:
 - (a) The applicant or his successor in interest has secured a building permit within said two-year period, if a building permit is required, and has actually commenced construction of the building or structure authorized by the permit within said two-year period.
 - (b) The applicant or his successor in interest has commenced the activity or installation of the facility or structure authorized by the conditional use permit within said two-year period.
- (2) The applicant may submit a written request to the City Council for an extension of time on the conditional use permit to avoid the permit's becoming null and void. The request for extension must be submitted prior to the expiration of the times established by Subsection (1) above. The City Council may, in the resolution granting such conditional use permit, provide for an extension of time beyond 1 year. [Ord. 743-88, 3/28/88; Ord. 1333-11 §2, 9/12/11]

Response: The Applicant is aware of the provision allowing for the automatic termination of a conditional use. Pending conditional use approval, the applicant's representative will be submitting for Architectural Review. Pending ARB approval, the applicant will be submitting for a building permit. Therefore, both a building permit and construction activity will ensue within the two-year window before a conditional use permit is terminated.

TDC 43: HIGH DENSITY RESIDENTIAL PLANNING DISTRICT (RH)

SECTION 43.010 PURPOSE.

To provide areas of the City suitable for townhouses, high density garden apartment and condominium developments. Within the Central Urban Renewal area, the uses permitted by this district may be mixed with uses permitted in the Central Commercial Planning District. [Ord. 661-85, § 8, 3/25/85; Ord. 868-92, § 8, 5/11/92; Ord. 933-94, § 22, 11/28/94; Ord. 956-96, § 28, 1/8/96; Ord 1025-99, §17, 7/26/99; Ord. 1109-02, 04/22/02]

Response: A small portion of the site is located in the RH zone and is co-terminus with Block 4 of the Urban Renewal Area. There is no development proposed in this area. The area instead is dedicated to circulation to the back of the retail stores and will be finished with paving only. Thus, there is no development proposed in the RH. Pursuant to 43.010, within the Central Urban Renewal Area, uses permitted by the district may be mixed with uses permitted in the Central Commercial Planning District. Vehicle circulation is permitted in both districts and therefore is an allowed use in the RH area of the site consistent with Chapter 43.

TDC 50: OFFICE COMMERCIAL PLANNING DISTRICT (CO)

SECTION 50.010 PURPOSE.

The purpose of this district is to provide areas for professional offices in locations adjacent to or across the street from residential areas. The district is intended to provide for office development ranging in size from small buildings with one or two tenants to large complexes housing business headquarters. Development design in this district shall be sensitive to the preservation of significant natural resources and shall provide extensive perimeter landscaping, especially adjacent to residential areas and streets.

Response: The proposed structures shown on the Site Plan in the CO district include building J-100, and the portion of Building 1040 discussed above. The Applicant understands the purpose of the Office Commercial planning district and has provided, as shown in the Site Plan, and discussed below, design-sensitive elements that incorporate the natural elements along the Tualatin River to the north and landscape screening to provide a buffer between the HR district to the west of the CO district.

SECTION 50.020 PERMITTED USES.

No building, structure or land shall be used in this district except for the following uses when conducted wholly within a completely enclosed building, except for utility facilities and wireless communication facilities, and provided retail uses on land designated Employment Area, Corridor or Industrial Area on [Map 9-4](#) shall not be greater than 60,000 square feet of gross floor area per building or business:

- (1) Offices, studios or clinics of accountants, architects, artists, attorneys, authors, dentists, designers, investment counselors, landscape architects, management consultants, and physicians or other practitioners of the healing arts.
- (2) Offices of administrative, editorial, educational, financial, governmental, insurance, real estate, religious, research, scientific or statistical organizations.

- (3) Health or fitness facility as defined in [TDC 31.060](#), with indoor operation only.
- (4) Greenways, including but not limited to bike and pedestrian paths and interpretive stations.
- (6) Parking lot, parking structure or underground parking.
- (11) Other uses of similar character, found by the Planning Director to meet the purpose of this district, as provided by [TDC 31.070](#).
- (12) Transportation facilities and improvements. [Ord. 635-84 §16, 6/11/84; Ord. 668-85 §2, 6/10/85; Ord. 771-89 §2, 4/10/89; Ord. 824-91 §6, 2/11/91; Ord. 849-91 §16, 11/25/91; Ord. 920-94 §13, 4/11/94; Ord. 965-96 §38, 12/9/96; Ord. 991-98 §1, 2/23/98; Ord. 992-98 §1, 2/23/98; Ord. 1006-98 §1;7/13/98; Ord. 1026-99 §42, 8/9/99; Ord. 1103-02, 03/25/02]

Response: The buildings within the CO zone contain uses that are permitted in the CO zone. Proposed uses for these buildings include office or health/fitness facility use and a portion of a sporting goods store. As this area of the site is within Block 1 of the Central Urban Renewal Plan, as discussed above, uses permitted in the CC District are allowed, subject to Chapter 32, in the CO District. All of the proposed uses proposed for the CO district are therefore allowed in the CO district.

SECTION 50.050 LOT SIZE.

Except for lots for public utility facilities, natural gas pumping stations and a wireless communication facility which shall be established through the Subdivision, Partition or Lot Line Adjustment process, the following requirements shall apply:

- (1) The minimum lot size shall be 10,000 square feet.
- (2) The minimum average lot width shall be 80 feet.
- (3) The minimum lot width at the street shall be 40 feet.
- (4) For flag lots, the minimum lot width at the street shall be sufficient to comply with at least the minimum access requirements contained in [TDC 73.400\(8\) to \(12\)](#).
- (5) The minimum lot width at the street shall be 40 feet on a cul-de-sac street. [Ord. 866-92, §13, 4/27/92; Ord. 965-96, §40, 12/9/96.; §50.055 Repealed by Ord. 862-92, §17, 3/23/92]

Response: A lot consolidation is included as a part of this application package in order to reduce the number of tax lots within Nyberg Rivers. The consolidated lot is greater than 10,000 SF, with an average lot width greater than 80 feet and a minimum lot width greater than 40 feet.

SECTION 50.060 SETBACK REQUIREMENTS.

- (1) Front yard. Except for townhouses whose set backs shall conform to the setback standards in the RH District, the minimum front yard setback shall be 20 feet, except where a fish and wildlife habitat area on the subject property is placed in a Tract and dedicated to the City at the City's option, dedicated in a manner approved by the City to a nonprofit conservation organization or is retained in private ownership by the developer, the decision authority may allow a reduction of up to 35% of the required front yard setback, as determined in the Architectural Review process, if as a result the buildings are farther away from fish and wildlife habitat areas.
- (2) Side yard. Except for townhouses whose setbacks and separation between buildings shall conform to the setback and separation standards in the RH District, and except for structures greater than 35 feet in height which shall have a setback of 30 feet when the subject side yard abuts a lot in the RL District and a setback of 20 to 30 feet as determined through the Architectural Review process when the subject side yard abuts a lot in a multifamily district, the side yard setback shall be zero to 15 feet, as determined through the Architectural Review process.
- (3) Rear yard. Except for townhouses whose setbacks and separation between buildings shall conform to the setback and separation standards in the RH District, and except for structures greater than 35 feet in height which shall have a setback of 30 feet when the subject rear yard abuts a lot in the RL District and a setback of 20 to 30 feet as determined through the Architectural Review process when the subject side yard abuts a lot in a multifamily district, the rear yard setback shall be zero to 15 feet, as determined through the Architectural Review process.
- (4) Corner lot yards. Except for town-houses whose setbacks shall conform to the setback standards in the RH District, zero to 20 feet along each street frontage for a sufficient distance to provide adequate sight distance for vehicular and pedestrian traffic at an intersection, as determined through the Architectural Review process.
- (5) Except for townhouses whose set-backs shall conform to the setback standards in the RH District, off-street parking and vehicular circulation areas shall be set back a minimum of 5 feet from any public right-of-way or property line, except as approved through the Architectural Review process.
- (6) Except for townhouses which may construct a fence on the property line, no fence shall be constructed within 5 feet of a public right-of-way.

Response: There are four buildings in the CO district: buildings J-100, M-100, N-100 and Building 1040. All buildings are oriented towards the interior of the site facing the central parking area. Therefore, the area between the building and the central drive aisles and parking stalls would be considered the front yard setback. All buildings feature a pedestrian accessway along the building frontage of at least

8-feet. And all off-street parking and vehicle circulation areas are set back at least 5-feet from any public right-of-way or property line.

SECTION 50.065 CENTRAL URBAN RENEWAL AREA--LOT SIZES.

Except for townhouses whose lot sizes shall conform to the lot size standards in the RH District, the minimum lot sizes in the Central Urban Renewal District are as described on [Map 9-3](#). [Ord. 694-86 §8, 5/27/86; Ord. 1025-99 §29, 7/26/99; Ord. 1026-99 §45, 8/9/99; Ord. 1046-00 §6, 2/14/00]

Response: As shown on Map 9-3 within the Central Urban Renewal Report, the minimum lot size for Blocks 1, 2, 3 and 5 is 25,000 SF. The site will undergo a lot consolidation to create a central lot that is 25.91 acres, well above the minimum lot requirement.

SECTION 50.070 STRUCTURE HEIGHT.

- (1) Except for flagpoles displaying the flag of the United States of America, either alone or with the State of Oregon flag which shall not exceed 100 feet in height above grade, and except as provided by subsection (2) of this section, the maximum height of any structure in this district is 45 feet.
- (2) Maximum structure height for a wireless communication support structure and antennas located within 300 feet of the centerline of I-5 is 120 feet. [Ord. 792-90, §1, 1/8/90; Ord. 965-96, S§42, 12/9/96; Ord 974-97, §2, 5/12/97; Ord. 978-97, §1, 6/23/97; Ord. 1116-02, 08/26/2002]

Response: The Applicant is aware of the maximum structure heights within the CO district. The proposed buildings are proposed within these height requirements.

SECTION 50.080 ACCESS.

All lots created after September 1, 1979, shall abut a public street, except secondary condominium lots, which shall conform to the access provisions in [TDC 73.400](#) and [TDC Chapter 75](#). Lots and tracts created to preserve wetlands, greenways, Natural Areas and Stormwater Quality Control Facilities identified by [TDC Chapters 71, 72, Figure 3-4](#) of the Parks and Recreation Master Plan and the Surface Water Management Ordinance, [TMC Chapter 3-5](#), as amended, respectively, or for the purpose of preserving park lands in accordance with the Parks and Recreation Master Plan, may not be required to abut a public street. [Ord. 872-92 §8, 6/29/92; Ord. 1025-99 §30, 7/26/99; Ord. 1026-99 §46, 8/9/99]

Response: The proposed single, consolidated lot abuts SW Nyberg Street, a public street. The proposed conservation area located at the northern end of Nyberg Rivers, adjacent to the Tualatin River and including the shared pathway easement, may be established as a lot or tract to preserve the natural area.

TDC 53: CENTRAL COMMERCIAL PLANNING DISTRICT (CC)

SECTION 53.010 PURPOSE.

The purpose of this district is to provide areas of the City that are suitable for a full range of retail, professional and service uses of the kind usually found in downtown areas patronized by pedestrians. The district also provides areas suitable for civic, social and cultural functions serving the general community. The district serves to implement the City's Central Urban Renewal Plan and, consequently, multi-family dwellings are also an appropriate use in certain portions of the district, as specified by the Central Urban Renewal Plan. [Ord. 1109-02, 04/22/02]

Response: The Applicant is aware of the general purpose of the Central Commercial (CC) planning district. The proposed uses for this district include retail, professional, and service uses at an intensity found in more of a dense, urban setting. The proposed uses are in line with the allowed uses classified in the City's Central Urban Renewal Plan. The intent of the proposed uses and scale of design at Nyberg Rivers is to create a seamless transition from the existing City Center and Tualatin Commons, consistent with this purpose statement.

SECTION 53.020 PERMITTED USES.

No building, structure or land shall be used except for the following uses when conducted wholly within a completely enclosed building, except for utility facilities and wireless communication facilities, and provided retail uses on land designated Employment Area, Corridor or Industrial Area on Map 9-4 shall not be greater than 60,000 square feet of gross floor area per building or business.

Response: All proposed uses in the CC District qualify as permitted uses in the CC District, excepting only outdoor storage and sales associated with the sporting goods store which constitutes a permitted use subject to Chapter 32. The outdoor storage and sales is addressed under the conditional use request above.

SECTION 53.060 LOT SIZES.

Except for lots for public utility facilities, natural gas pumping stations and wireless communication facilities which shall be established through the Subdivision, Partition or Lot Line Adjustment process, the following requirements shall apply:

- (1) The minimum lot area shall be 10,000 square feet.
- (2) The minimum average lot width shall be 75 feet.
- (3) The minimum lot width at the street shall be 40 feet.
- (4) For flag lots, the minimum lot width at the street shall be sufficient to comply with at least the minimum access requirements contained in TDC 73.400(8) to (12).
- (5) The minimum lot width at the street shall be 40 feet on a cul-de-sac street. [Ord. 866-92, §15, 4/27/92; Ord. 965-96, §48, 12/9/96]

Response: A lot consolidation is included as a part of this application package. The consolidated lot is greater than 10,000 SF, with an average lot width greater than 80 feet and a minimum lot width greater than 40 feet.

SECTION 53.070 CENTRAL URBAN RENEWAL AREA - LOT SIZES.

Except for lots for public utility facilities, natural gas pumping stations and wireless communication facilities which shall be established through the Subdivision, Partition or Lot Line Adjustment process, and excepting any lot in the Core Area Parking District where TDC 53.070(1)-(5) apply, the minimum lot size in the Central Urban Renewal District shall conform to the lot sizes described on Map 9-3:

- (1) Except for mixed use developments, and common-wall dwellings on separate lots:
 - (a) The minimum lot area shall be 5,000 square feet.
 - (b) The minimum average lot width shall be 40 feet.
 - (c) The minimum lot width at the street shall be 40 feet.
 - (d) For flag lots, the minimum lot width at the street shall be sufficient to comply with at least the minimum access requirements in TDC 73.400(8) - (12).
 - (e) The minimum lot width at the street shall be 35 feet on a cul-de-sac street.
- (2) For mixed use developments, and common-wall dwellings on separate lots:
 - (a) Lot areas, widths and frontages shall be determined through the Architectural Review Process.
 - (b) Frontage on a public street shall not be required when access via easements is provided in accordance with TDC 73.400.
- (3) The minimum lot width at the street shall be 40 feet.
- (4) For flag lots, the minimum lot width at the street shall be sufficient to comply with at least the minimum access requirements in TDC 73.400(8) - (12).
- (5) The minimum lot width at the street shall be 40 feet on a cul-de-sac street. [Ord. 635-84 §24, 6/11/84; Ord. 694-86 §6, 5/27/86; Ord. 872-92 §11, 6/29/92; Ord. 882-92 §7, 12/14/92; Ord. 965-96 §49, 12/9/96; Ord. 1026-99 §58, 8/9/99]

Response: A lot consolidation is included as a part of this application package. The consolidated lot is greater than 5,000 SF, with an average lot width greater than 40 feet and a minimum lot width greater than 40 feet.

SECTION 53.080 SETBACK REQUIREMENTS.

- (1) Front yard. Except as provided by TDC 53.090(2)(a), zero to 20 feet, as determined through the Architectural Review process.
- (2) Side yard. Except as provided by TDC 53.090(2)(a), zero to 20 feet, as determined through the Architectural Review process.
- (3) Rear yard. Zero to 15 feet, as determined through the Architectural Review process.

- (4) Corner lot yards. Zero to 20 feet for a sufficient distance to provide adequate sight distance for vehicular and pedestrian traffic at an intersection, as determined through the Architectural Review process.
- (5) Off-street parking and vehicular circulation areas shall be set back a minimum of 5 feet from any public right-of-way or property line, except as approved through the Architectural Review process.
- (6) No fence shall be constructed within 5 feet of a public right-of-way, except that in residential and mixed use residential developments within the Central Design District the minimum fence setback shall be determined through Architectural Review, with no minimum requirement.
- (7) For residential garage doors facing a public street, the minimum setback shall be 20' from the right-of-way.
- (8) Setbacks for a wireless communication facility shall be established through the Architectural Review process, shall consider TDC 73.510, shall be a minimum of 5 feet, and shall be set back from an RL District, or an RML District with an approved small lot subdivision, no less than 175 feet for a monopole that is no more than 35 feet in height and the setback shall increase five feet for each one foot increase in height up to 80 feet in height, and the setback shall increase 10 feet for each one foot increase in height above 80 feet. [Ord. 643-84, §2, 9/10/84; Ord. 862-92, §27, 3/23/92; Ord. 882-92, §8, 12/14/92; Ord. 904-93, §24, 9/13/93; Ord. 965-96, §50, 12/9/96; Ord. 1098-02, 2/11/02]

Response: All buildings are oriented towards the interior of the site facing the central parking area. Therefore, the area between the building and the central drive aisles and parking stalls would be considered the front yard setback. All buildings feature a pedestrian accessway along the building frontage of at least 8-feet. And all off-street parking and vehicle circulation areas are set back at least 5-feet from any public right-of-way or property line. Specific setback dimensions will be determined and addressed at the time of ARB submittal.

SECTION 53.090 STRUCTURE HEIGHT.

- (1) Except for flagpoles displaying the flag of the United States of America, either alone or with the State of Oregon flag which shall not exceed 100 feet in height above grade, and except as provided in TDC 53.090(2), (3) and (4), the maximum height for a structure is 45 feet.
- (2) In the CC Planning District north of SW Boones Ferry Road and south of the Tualatin River, the maximum height for a structure is 125 feet, when approved by Conditional Use Permit pursuant to TDC Chapter 32 and subject to the following setback requirements:
 - (a) Front yard. Any structure south of Hedges Creek shall comply with the CC District setbacks and any structure north of Hedges Creek shall comply with the TDC Chapter 72 setbacks for Hedges Creek.
 - (b) Side yard. The minimum side yard setback shall be:

- (i) For structures 45 feet or less in height, zero to 15 feet as determined through the Architectural Review process.
 - (ii) For structures greater than 45 feet, but less than 84 feet, the side yard setback shall be 30 feet for that portion of the structure greater than 45 feet and less than 84 feet in height.
 - (iii) For structures greater than 84 feet but less than or equal to 125 feet in height, the side yard setback shall be 45 feet for that portion of the building greater than 84 feet in height.
- (3) Maximum structure height for specified portions of the Central Urban Renewal Plan area is:
- (a) 35 feet between the Tualatin Commons central water feature and the primary pedestrian corridor around the central water feature, except for architectural focal elements.
 - (b) Except as provided in TDC 53.090(3)(a), 75 feet in Block 13.
 - (c) Except as provided in TDC 53.090(3)(a), 60 feet in Blocks 1, 2, 3, 5, 14, 15, 16, 17, 18, 19, 20 and 22.
 - (d) 75 feet for architectural focal elements in Blocks 14, 17, 18 and 20.
- (4) Maximum structure height for a wireless communication support structure and antennas located within 300 feet of the centerline of I-5 is 120 feet. [Ord. 792-90 §2, 1/8/90; Ord. 882-92 §9, 12/14/92; Ord. 965-96 §51, 12/9/96; Ord. 1026-99 §59, 8/9/99; Ord. 1116-02, 8/26/02; Ord. 1109-02, 4/22/02]

Response: The applicant is aware of the maximum structure heights within the CC district. The proposed maximum height for all structures located on-site will not exceed the requirements identified above.

SECTION 53.100 ACCESS.

Except as provided below, no lot shall be created without provision for access to the public right-of-way in accordance with TDC 73.400 and TDC Chapter 75. Such access may be provided by lot frontage on a public street, or via permanent access easement over one or more adjoining properties, creating uninterrupted vehicle and pedestrian access between the subject lot and the public right-of-way. Lots and tracts created to preserve wetlands, greenways, Natural Areas and Stormwater Quality Control Facilities identified by TDC Chapters 71, 72, Figure 3-4 of the Parks and Recreation Master Plan and the Surface Water Management Ordinance, TMC Chapter 3-5, as amended, respectively, or for the purpose of preserving park lands in accordance with the Parks and Recreation Master Plan, may not be required to abut a public street. [Ord. 872-92 §12, 6/29/92; Ord. 882-92 §10, 12/14/92; Ord. 979-97 §21, 7/14/97; Ord. 1026-99 §60, 8/9/99]

Response: The proposed single, consolidated lot abuts SW Nyberg Street, a public street and takes primary access from that public street in compliance with this criterion.

The proposed natural area located at the northern end of Nyberg Rivers, adjacent to the Tualatin River and including the shared pathway easement will be established as a lot or tract to preserve the natural area.

TDC 73: COMMUNITY DESIGN STANDARDS

SECTION 73.140 SITE PLANNING - COMMERCIAL, INDUSTRIAL, PUBLIC AND SEMI-PUBLIC USES.

Purpose.

The purpose of commercial, industrial, public and semi-public site planning design objectives is to implement the purposes and objectives of TDC 73.020(2) by focusing on the placement, design and relationship of proposed site elements such as buildings, vehicular parking and circulation areas, bikeways and bike parking, accessways, walkways, buffer areas and landscaping. [Ord. 862-92, §51, 3/23/92; Ord. 895-93, §7, 5/24/93]

Response: The Applicant is aware of the purpose of commercial site planning and design objectives to reflect the purposes and objectives of the development code. The Site Plan (Exhibit C) and Master Plan document (Exhibit A) provided with this project narrative demonstrates that Nyberg Rivers addresses and is consistent with all community design standards as addressed below.

SECTION 73.150 OBJECTIVES.

All commercial, industrial, public and semi-public projects should strive to meet the following objectives to the maximum extent practicable. Architects and developers should consider these elements in designing new projects. In the Central Design District, the Design Guidelines of TDC 73.610 shall be considered. In the case of conflicts between objectives, the proposal shall provide a desirable balance between the objectives. Site elements shall be placed and designed, to the maximum extent practicable, to:

- (1) Provide convenient walkways and crosswalks which separate pedestrians from vehicles and link primary building entries to parking areas, other on-site buildings and the public right-of-way.

Response: As demonstrated in the Pedestrian & Bicycle Plan included as a part of the Nyberg Rivers Master Plan and included with this application as Exhibit A, separate pedestrian walkways and crosswalks are provided along the primary building entrances from the parking areas, between buildings, and to the adjacent public right-of-ways.

- (2) Avoid barriers to disabled individuals.

Response: The Site Plan included with this application as Exhibit C shows ADA compliant parking stalls located in the central parking area nearest the primary entrances to the buildings. These stalls are adjacent to pedestrian crossing areas that provide safe access to the buildings.

- (3) **Locate and design drive-through facilities in a manner which does not conflict with pedestrian routes or other vehicular circulation and minimizes adverse impacts on adjacent properties.**

Response: As shown on the Site Plan included as Exhibit C, all drive-through facilities are sited to negate any conflict with pedestrian routes or vehicular circulation accessways. The drive-through facilities are located between the building and the property line or right-of-way, aside from the central parking area and pedestrian access paths.

- (4) **Break up parking areas with landscaping (trees, shrubs and walkways) and buildings to lessen the overall impact of large paved areas.**

Response: The Landscape Planting Plan included as Sheet L1.0 within the Exhibit C- Site Plan Set, does show trees, shrubs, groundcover and landscape islands that work to lessen the overall impact of the large paved parking area.

- (5) **Utilize landscaping in parking areas to direct and control vehicular movement patterns, screen headlights from adjacent properties and streets, and lessen the visual dominance of pavement coverage.**

Response: The Landscape Planting Plan included as Sheet L1.0 within the Exhibit C- Site Plan Set, does create natural corridors for vehicular movement while also working to break up the visual dominance of the pavement coverage. The site perspective exhibits provided with this submittal under Exhibit C demonstrates the general environment and sense of place that will be promoted at Nyberg Rivers.

- (6) **Provide vehicular connections to ad-joining sites.**

Response: The Site Plan and the supporting Master Plan exhibits do demonstrate the vehicular connections through the site, with connections to adjoining sites and streets that support the local and regional traffic circulation pattern. The Transportation Plan, included as a part of the Nyberg Rivers Master Plan, does show those primary access points into the site.

- (7) **Emphasize entry drives into commercial complexes and industrial park developments with special design features, such as landscaped medians, water features and sculptures.**

Response: The central entry drive into the site is provided from SW Nyberg Street. This entry will be emphasized with enhanced landscape plantings and signage to welcome the visitor into the site. The proposed landscape plantings are shown on Sheet L1.0 and additional landscape elements for the central drive aisle and building frontages are shown in the Master Plan document included as Exhibit A with this application.

- (8) **Locate, within parking lots, pedestrian amenities and/or landscaping in areas which are not used for vehicle maneuvering and parking.**

Response: The Bicycle & Pedestrian Plan included with the Master Plan document as Exhibit A and the Landscape Planting Plan included as Sheet L1.0 within the Exhibit C- Site Plan Set, does show pedestrian amenities and landscaping in areas set aside as plazas, sidewalks or vegetation areas to enhance the aesthetics and feel of the Nyberg Rivers redevelopment.

- (9) **Encourage outdoor seating areas which provide shade during summer and sun during winter, trash receptacles and other features for pedestrian use. Plantings with a variety of textures and color are encouraged.**

Response: A central pedestrian plaza is shown between Buildings 1010 and 1040 that will provide outdoor seating areas. As shown on the Landscape Planting Plan within Exhibit C and the Master Plan document, plantings and amenities will be featured along the buildings frontages to create a sense of place and scale suitable to a pedestrian environment.

- (10) **Create opportunities for, or areas of, visual and aesthetic interest for occupants and visitors to the site.**

Response: The Nyberg Rivers Master Plan document, enclosed as Exhibit A, does show examples of landscaping and building elements and articulation that will create areas of visual and aesthetic interest for visitors to the site.

- (11) **Conserve, protect and restore fish and wildlife habitat areas, and maintain or create visual and physical corridors to adjacent fish and wildlife habitat areas.**

Response: As stated in the Natural Resource Assessment provided by Pacific Habitat Services and included with this application under Exhibit G, a shared pathway easement will be provided through the natural area located just north of the Nyberg Rivers commercial area and adjacent to the Tualatin River. This easement will provide an opportunity for both a visual and physical corridor to the natural area.

- (12) **Provide safe pathways for pedestrians to move from parking areas to building entrances.**

Response: As demonstrated in the Pedestrian & Bicycle Plan included as a part of the Nyberg Rivers Master Plan and included with this application as Exhibit A, separate pedestrian walkways and crosswalks are provided along the primary building entrances from the parking areas, between buildings, and to the adjacent public right-of-ways.

- (13) **Design the location of buildings and the orientation of building entrances for commercial, public and semi-public uses such as churches, schools and hospitals to provide adequate pedestrian circulation between buildings and to provide preferential access for pedestrians to existing or planned transit stops and transit stations.**

Response: As demonstrated in the Pedestrian & Bicycle Plan included as a part of the Nyberg Rivers Master Plan and included with this application as Exhibit A, separate pedestrian walkways and crosswalks are provided along the primary

building entrances from the parking areas, between buildings, and to the adjacent public right-of-ways. There is an existing bus transit stop located along SW Martinazzi Avenue, directly west of the site. Pedestrian and bicycle connectivity is provided to the bus stop.

- (14) **Provide accessways between commercial, public and semi-public development and publicly-owned land intended for general public use; arterial and collector streets where a transit stop and/or a bike lane is provided or designated; and abutting residential, commercial and semi-public property.**

Response: As demonstrated in the Pedestrian & Bicycle Plan included as a part of the Nyberg Rivers Master Plan and included with this application as Exhibit A, separate pedestrian walkways and crosswalks are provided along the primary building entrances from the parking areas, between buildings, and to the adjacent public right-of-ways. There is an existing bus transit stop located along SW Martinazzi Avenue, directly west of the site. Pedestrian and bicycle connectivity is provided to the bus stop.

- (15) **Accessways should be designed and located in a manner which does not restrict or inhibit opportunities for developers of adjacent properties to connect with an accessway, and provide continuity from property to property for pedestrians and bicyclists to use the accessway.**

Response: As demonstrated in the Pedestrian & Bicycle Plan included as a part of the Nyberg Rivers Master Plan and included with this application as Exhibit A, separate pedestrian walkways and crosswalks are provided along the primary building entrances from the parking areas, between buildings, and to the adjacent public right-of-ways. These accessways and their locations do not restrict or inhibit opportunities for developers of adjacent properties to connect with an accessway.

- (16) **Provide preferential parking for carpool and vanpools to encourage employees to participate in carpools and vanpools.**

Response: Carpool or vanpool designated spots have not been demarcated at this time. However, the applicant will work with the City to address carpool and vanpool parking if needed.

- (17) **Screen elements such as mechanical and electrical equipment, above ground sewer or water pump stations, pressure reading stations and water reservoirs from view.**

Response: At this time, the locations of mechanical and electrical equipment have not been determined and no sewer or water pump stations are proposed. Adequate screening and types of materials used for screening will be addressed at the time of ARB submittal.

- (20) **When a fish and wildlife habitat area abuts or is on the subject property the applicant and decision authority for a development application should consider locating buildings farther away from the fish and wildlife habitat area. [Ord. 635-84, § 36, 6/11/84; Ord. 649-84, §7, 11/26/84; Ord. 661-85, §10, 3/25/85; Ord. 827-91,**

§6 and 7, 3/25/91; Ord. 849-91, §38 and 39, 11/25/91; Ord. 862-92, §51, 3/23/92; Ord. 895-93, §8, 5/24/93; Ord. 904-93, §47, 9/13/93; Ord. 920-94, §17, 4/11/94; Ord. 965-96, §82, 12/9/96; Ord. 979-97, §52, 7/14/97; Ord. 1097-02, 2/11/02; Ord. 1224-06 §22, 11/13/06]

Response: The natural area denoted on the Site Plan is located adjacent to the proposed commercial center. As stated in the natural resource assessment provided with this application, this access easement will provide access through the natural area, but all buildings and development will be directed away from this natural area.

SECTION 73.160 STANDARDS.

The following standards are minimum requirements for commercial, industrial, public and semi-public development, and it is expected that development proposals shall meet or exceed these minimum requirements.

(1) Pedestrian and Bicycle Circulation.

(a) For commercial, public and semi-public uses:

- (i) a walkway shall be provided between the main entrance to the building and any abutting public right-of-way of an arterial or collector street where a transit stop is designated or provided. The walkway shall be a minimum of 6 feet wide and shall be constructed of concrete, asphalt, or a pervious surface such as pavers or grasscrete, but not gravel or woody material, and be ADA compliant, if applicable;**
- (ii) walkways shall be provided between the main building entrances and other on-site buildings and accessways. The walkways shall be a minimum of 6 feet wide and shall be constructed of concrete, asphalt, or a pervious surface such as pavers or grasscrete, but not gravel or woody material, and be ADA compliant, if applicable;**
- (iii) walkways through parking areas, drive aisles, and loading areas shall be visibly raised and of a different appearance than the adjacent paved vehicular areas;**
- (iv) accessways shall be provided as a connection from the development's internal bikeways and walkways to all of the following locations that apply: abutting arterial or collector streets upon which transit stops or bike lanes are provided or designated; abutting undeveloped residential or commercial areas; adjacent undeveloped sites where an agreement to provide an accessway connection exists; and to abutting publicly-owned land intended for general public use, including schools;**
- (v) fences or gates which prevent pedestrian and bike access shall not be allowed at the entrance to or exit from any accessway.**

- (vi) **bikeways shall be provided which link building entrances and bike facilities on the site with the adjoining public right-of-way and accessways.**
- (vii) **Outdoor Recreation Access Routes shall be provided between the development's walkway and bikeway circulation system and parks, bikeways and greenways where a bike or pedestrian path is designated.**

Response: As demonstrated in the Pedestrian & Bicycle Plan included as a part of the Nyberg Rivers Master Plan and included with this application as Exhibit A, separate pedestrian walkways and crosswalks are provided along the primary building entrances from the parking areas, between buildings, and to the adjacent public right-of-ways. The specific type of material has not been determined at this time, but the applicant will work with the City to achieve an accessway to meet City standards.

- (c) **Curb ramps shall be provided wherever a walkway or accessway crosses a curb.**

Response: Curb ramps will be provided on-site wherever a walkway or accessway crosses a curb.

- (d) **Accessways shall be a minimum of 8 feet wide and constructed in accordance with the Public Works Construction Code if they are public accessways, and if they are private access-ways they shall be constructed of asphalt, concrete or a pervious surface such as pervious asphalt or concrete, pavers or grasscrete, but not gravel or woody material, and be ADA compliant, if applicable.**

Response: All proposed accessways along the building frontages will be a minimum of 8-feet wide and constructed to Public Works Construction Code standard.

- (e) **Accessways to undeveloped parcels or undeveloped transit facilities need not be constructed at the time the subject property is developed. In such cases the applicant for development of a parcel adjacent to an undeveloped parcel shall enter into a written agreement with the City guaranteeing future performance by the applicant and any successors in interest of the property being developed to construct an accessway when the adjacent undeveloped parcel is developed. The agreement shall be subject to the City's re-view and approval.**

Response: The Nyberg Rivers commercial center will be developed in whole, with no proposed undeveloped parcels. Therefore, this criterion does not apply.

- (g) **Accessways shall be constructed, owned and maintained by the property owner.**

Response: The attached Site Plan (Exhibit C) and Pedestrian & Bicycle Plan within the Master Plan document (Exhibit A) demonstrate that the proposed Nyberg Rivers Master Plan meets these objectives. Specifically, the Ped & Bike Plan does

include walkways and crosswalks to accommodate both pedestrian and bicycle access between primary entrances to each building, as well as access through the site to connect to the larger downtown network. The proposed cross sections shown on the Transportation Plan (Sections A-A, B-B, and C-C) show a shared roadway section for bicycle and vehicle traffic, while the sidewalk will be curb-tight. The walkways through the parking area will be visibly raised with a different material treatment than the surrounding parking area. Curb ramps will be provided wherever a walkway or accessway crosses a curb and all accessways will be a minimum of 8-feet wide and constructed to the terms of the Public Works Code. Those accessways will be constructed, owned and maintained by the property owner.

(2) Drive-up Uses.

- (a) Drive-up uses shall provide a minimum stacking area clear of the public right-of-way and parking lot aisles from the window serving the vehicles as follows:**
- (i) Banks--each lane shall provide a minimum capacity for five automobiles.**
 - (ii) Restaurants--each lane shall provide a minimum capacity for eight automobiles.**
 - (iii) Other Drive-Up Uses--each lane shall provide a minimum capacity for two to eight automobiles, as determined through the architectural review process.**
 - (iv) For purposes of this Section, an automobile shall be considered no less than twenty feet in length. The width and turning radius of drive-up aisles shall be approved through the architectural review process.**
- (b) Parking maneuvers shall not occur in the stacking area. The stacking area shall not interfere with safe and efficient access to other parking areas on the property.**
- (c) Locate drive-up aisles and windows a minimum of 50 feet from residential planning districts to avoid adverse impacts. A wall or other visual or acoustic may be required through the architectural review process.**

Response: One new Drive-up window is proposed to be located within the center. The Applicant has demonstrated with the site plan that proposed building H-100 can meet the standard. Additional drive-up requirements will be reviewed during the subsequent Architectural Review process.

(3) Safety and Security.

- (a) Locate windows and provide lighting in a manner which enables tenants, employees and police to watch over pedestrian, parking and loading areas.**

- (b) In commercial, public and semi-public development and where possible in industrial development, locate windows and provide lighting in a manner which enables surveillance of interior activity from the public right-of-way.
- (c) Locate, orient and select on-site lighting to facilitate surveillance of on-site activities from the public right-of-way without shining into public rights-of-way or fish and wildlife habitat areas.
- (d) Provide an identification system which clearly locates buildings and their entries for patrons and emergency services.
- (e) Shrubs in parking areas must not exceed 30 inches in height. Tree canopies must not extend below 8 feet measured from grade.
- (f) Above ground sewer or water pumping stations, pressure reading stations, water reservoirs, electrical substations, and above ground natural gas pumping stations shall provide a minimum 6' tall security fence or wall.

Response: As shown on the building elevations and perspective view exhibits, each of the buildings feature a large percentage of glazing along the building exterior, primarily along the front building façade, creating eyes to the public places. Also, lighting will be provided throughout the site, both in the internal parking area, as well as the pedestrian accessways and plazas throughout the site. A site Photometric Plan will be addressed and included as a part of the ARB submittal. The Site Plan included with this application (Exhibit C) demonstrates safe and efficient access into and through the site, both for pedestrian and vehicle access. The central entry located at Nyberg Street provides a focal entry point to the major tenant spaces, with signage to direct visitors through the site. As shown on the Landscape Planting Plan under Exhibit C, parking lot landscaping will not exceed 30 inches in shrub height and tree canopies will not extend below 8 feet measured from grade. Landscaping and pathways will also assist with directing pedestrians and provide safe visibility corridors throughout the site. The Landscape Planting Plan and the landscape elements outlined in the Master Plan document display the landscape elements and amenities to be provided throughout the site. These elements will combine to provide a safe and secure site.

(4) Service, Delivery and Screening.

- (a) On and above grade electrical and mechanical equipment such as transformers, heat pumps and air conditioners shall be screened with sight obscuring fences, walls or landscaping.
- (b) Outdoor storage, excluding mixed solid waste and source separated recyclables storage areas listed under TDC 73.227, shall be screened with a sight obscuring fence, wall, berm or dense evergreen landscaping.
- (c) Above ground pumping stations, pressure reading stations, water reservoirs; electrical substations, and above ground natural gas pumping stations shall be screened with sight-obscuring fences or walls and landscaping.

Response: Specific locations for mechanical equipment have not been determined at this time. Outdoor storage areas are shown on the attached Site Plan and those areas will be screened with a site obscuring fence, wall, or dense evergreen landscaping. There are no above-ground pumping stations or water reservoirs proposed on-site.

- (5) **The Federal Americans with Disabilities Act (ADA) applies to development in the City of Tualatin. Although TDC, Chapter 73 does not include the Oregon Structural Specialty Code's (OSSC) accessibility standards as requirements to be reviewed during the Architectural Review process, compliance with the OSSC is a requirement at the Building Permit step. It is strongly recommended all materials submitted for Architectural Review show compliance with the OSSC.**

Response: The Applicant is aware of the OSSC and ADA requirement and will provide adequate materials at the time of ARB submittal. Generally, the ADA parking stalls shown on the Site Plan provide safe and adequate access to pedestrian accessways and building frontages to meet ADA standards. Those ADA stalls are marked on the Site Plan.

(6)

- (a) **All industrial, institutional, retail and office development on a transit street designated in TDC Chapter 11 (Figure 11-6) shall provide either a transit stop pad on-site, or an on-site or public sidewalk connection to a transit stop along the subject property's frontage on the transit street.**
- (b) **In addition to (a) above, new retail, office and institutional uses abutting major transit stops as designated in TDC Chapter 11 (Figure 11-6) shall:**
- (i) **locate any portion of a building within 20 feet of the major transit stop or provide a pedestrian plaza at the transit stop;**
 - (ii) **provide a reasonably direct pedestrian connection between the major transit stop and a building entrance on the site;**
 - (iii) **provide a transit passenger landing pad accessible to disabled persons;**
 - (iv) **provide an easement or dedication for a passenger shelter as determined by the City; and**
 - (v) **provide lighting at the major transit stop. [Ord. 862-92, §51, 3/23/92; Ord. 895-93, §9, 5/24/93; Ord. 898-93, §5, 6/14/93; Ord. 904-93, §48, 49 and 50, 9/13/93; Ord. 947-95, §8, 9, 10 and 11, 7/24/95; Ord. 965-96, §83 and 84, 12/9/96; Ord. 1008-98, §6, 7/13/98; Ord. 1046-00 §35, 2/14/00; Ord. 1103-02, , 3/25/02; Ord. 1224-06 §23, 11/13/06]**

Response: Martinazzi Blvd is classified as a transit street, with a bus line and bus stop located near the City Library, just west of Nyberg Rivers. Pedestrian and bicycle accessways are provided from the site to the transit stop. The transit stop provides a covered bench and waiting area, trash receptacle and bicycle rack.

SECTION 73.200 STRUCTURE DESIGN - COMMERCIAL, INDUSTRIAL, PUBLIC AND SEMI-PUBLIC USES.

Purpose.

The purpose of commercial, industrial, public and semi-public building design objectives and standards is to implement the purpose and objectives of TDC 73.020(2) and are intended to promote functional, safe, innovative and attractive buildings which are compatible with the surrounding environment. This concerns the building form including the articulation of walls and roof design, materials, colors, placement of elements such as windows, doors, mechanical equipment and identification features. [Ord. 705-86, §6, 9/8/86]

Response: This narrative, the attached Site Plan, and the building elevations and view perspectives provided with this submittal package demonstrate that the design and layout of the site and the buildings promote functional, safe, innovative and attractive buildings which are compatible with the surrounding environment. This is primarily achieved through building articulation, materials, colors, and the placement of glazing, doors, and other identification features. More specific building materials and elevations will be submitted and reviewed at the time of ARB application. Site design elements combine with the structure design to create a safe, innovative, and attractive redevelopment project that ties into the existing infrastructure and provides a transition to the natural area along the Tualatin River to the north of the site.

SECTION 73.210 OBJECTIVES.

All commercial, industrial, public and semi-public projects should strive to meet the following objectives to the maximum extent practicable. Architects and developers should consider these elements in designing new projects. In the Central Design District, the Design Guidelines of TDC 73.610 shall be considered. In case of conflicts between objectives, the proposal shall provide a desirable balance between the objectives. Buildings shall be designed, to the maximum extent practicable, to:

- (1) Minimize disruption of natural site features such as topography, trees and water features.
- (2) Provide a composition of building elements which is cohesive and responds to use needs, site context, land form, a sense of place and identity, safety, accessibility and climatic factors. Utilize functional building elements such as arcades, awnings, entries, windows, doors, lighting, reveals, accent features and roof forms, whenever possible, to accomplish these objectives.
- (3) Where possible, locate loading and service areas so that impacts upon surrounding areas are minimized. In industrial development loading docks should be oriented inward to face other buildings or other loading docks. In commercial areas loading docks should face outward towards the public right-of-way or perimeter of the site or both.

- (4) Enhance energy efficiency in commercial and industrial development through the use of landscape and architectural elements such as arcades, sunscreens, lattice, trellises, roof overhangs and window orientation.
- (5) Locate and design entries and loading/service areas in consideration of climatic conditions such as prevailing winds, sun and driving rains.
- (6) Give consideration to organization, design and placement of windows as viewed on each elevation having windows. Surveillance over parking areas from the inside, as well as visual surveillance from the outside in, should be considered in window placement.
- (7) Select building materials which contribute to the project's identity, form and function, as well as to the surrounding environment.
- (8) Select colors in consideration of lighting conditions and the context under which the structure is viewed, the ability of the material to absorb, reflect or transmit light and the color's functional role (e.g., to identify and attract business, aesthetic reasons, image-building).
- (9) Where possible, locate windows and provide lighting in a manner which enables tenants, employees and police to watch over pedestrian, parking and loading areas.
- (10) Where practicable locate windows and provide lighting in a manner which enables surveillance of interior activity from the public right-of-way or other public areas. [Ord. 904-93, §51, 9/13/93; Ord. 1097-02, 2/11/02]

Response: As shown on the attached Site Plan and supporting master plan exhibits and building elevations, the Nyberg Rivers site was configured to minimize disruption to site features, primarily those features located at the northern portion of the site that includes a natural area, the Tualatin River floodplain, and a grove of significant trees. The building elements and materials selected for Nyberg Rivers provides a palette of colors, materials, and design elements that create a sense of place and identity for the site. Glazing on the buildings is located in the central portion of many buildings, providing visual corridors both into the tenant spaces and out to the surrounding pedestrian and parking areas. The attached building elevations and perspective views provided under Exhibit C with this application demonstrate the general architectural aesthetic for each building. These elements combine to create a sense of place at Nyberg Rivers that also provides safe and efficient access into and through the site for both pedestrians and vehicular traffic.

SECTION 73.220 STANDARDS.

The following standards are minimum requirements for commercial, industrial, public and semi-public development and it is expected that development proposals shall meet or exceed these minimum requirements.

- (1) Safety and Security.

- (a) Locate, orient and select on-site lighting to facilitate surveillance of on-site activities from the public right-of-way or other public areas without shining into public rights-of-way or fish and wildlife habitat areas.
- (b) Provide an identification system which clearly identifies and locates buildings and their entries.
- (c) Shrubs in parking areas shall not exceed 30 inches in height, and tree canopies must not extend below 8 feet measured from grade, except for parking structures and underground parking where this provision shall not apply. [Ord. 904-93, §52, 9/13/93; Ord. 20-94, §18, 4/11/94; Ord. 1224-06 §24, 11/13/06]

Response: The Applicant is aware of the site lighting, signage, and landscaping requirements listed above that pertain to safety and easy way finding throughout Nyberg Rivers. Adequate lighting will be provided on-site, as will be demonstrated in the site photometric plan provided at the time of ARB submittal. Adequate signage will be provided to guide users into the site, as well as directing them to the specific tenant areas within the different buildings. All parking lot landscaping will conform to the requirements listed above in order to ensure clear vision corridors.

SECTION 73.221 PURPOSE AND OBJECTIVES.

- (1) Purpose. The purpose of fence design standards in the RL and RML Planning Districts for access-restricted lot lines and property lines abutting major and minor collector and arterial and expressway streets and interstate highways (I-5 or I-205) is to implement the community design objectives of TDC 10.020.
- (2) Objectives. Fences shall be designed to the maximum extent practicable, to achieve the following:
 - (a) Rear yards and side yards adjacent collector, arterial and expressway streets and interstate highways shall be screened from public view.
 - (b) Fences shall be constructed of highly durable materials that are low-maintenance and weather-resistant.
 - (c) Fence materials and design shall be compatible and harmonious with the required fence design type detailed in TDC 34.330 and 34.340. The design shall incorporate stone-look or brick-look elements. Colors shall be subdued and natural earth-tones, brown-tones, or grey-tones. [Ord. 1244-07 §5, 7/23/07, Ord. 1285-09 §4, 7/13/09]

Response: No fences are proposed with this Master Plan application.

SECTION 73.222 FENCE STANDARDS.

Minimum requirements for construction of fences in a RL or a RML Planning District, where an access-restricted lot line or property line abuts a public street right-of-way classified as a major or minor collector or arterial or expressway street, or a property line of a state-owned interstate high-way are set forth in TDC 34.330 and 34.340. [Ord. 1244-07 §6, 7/23/07, Ord. 1285-09 §5, 7/13/09]

Response: No fences are proposed with this Master Plan application.

SECTION 73.225 MIXED SOLID WASTE AND SOURCE SEPARATED RECYCLABLES STORAGE AREAS FOR NEW OR EXPANDED MULTI-UNIT RESIDENTIAL, INCLUDING TOWNHOUSES, COMMERCIAL, INDUSTRIAL, PUBLIC AND SEMI-PUBLIC DEVELOPMENT.

Purpose.

The purpose of mixed solid waste and source separated recyclables storage areas objectives and standards is to implement the purposes and objectives of TDC 73.020(2). The objectives and standards are intended to be flexible, easy and efficient to administer, and allow creativity. [Ord. 898-93, §6, 6/14/93. Ord. 1025-99, §39, 7/26/99; Ord. 1097-02, 2/11/02]

Response: The Applicant is aware of the purpose behind storage for mixed solid waste and source separated recyclables. Screening of these storage areas will be provided either through a fence, wall, or landscape screening. The exact design will be reviewed at the time of Architectural Review.

SECTION 73.226 OBJECTIVES.

All new or expanded multi-family, including townhouses, commercial, industrial, public and semi-public projects should strive to meet the following objectives to the maximum extent practicable. Architects and developers should consider these elements in designing new projects. In the Central Design District, the Design Guidelines of TDC 73.610 shall be considered. In the case of conflicts between objectives, the proposal shall provide a desirable balance between the objectives. Townhouses may necessitate a different balancing than multi-family developments such as apartments. Mixed solid waste and source separated recyclable storage areas shall be designed to the maximum extent practicable, to:

- (1) Screen elements such as garbage and recycling containers from view.
- (2) Ensure storage areas are centrally located and easy to use.
- (3) Meet dimensional and access requirements for haulers.
- (4) Designed to mitigate the visual impacts of storage areas.
- (5) Provide adequate storage for mixed solid waste and source separated recyclables.

- (6) Improve the efficiency of collection of mixed solid waste and source separated recyclables. [Ord. 898-93, §7, 6/14/93. Ord. 1025-99, §40, 7/26/99; Ord. 1097-02, 2/11/02]

Response: The Nyberg Rivers redevelopment can provide adequate screening for recycling and garbage storage areas, although the specific type of screening (fence, wall, and landscape screen) has not been selected for each application. The storage areas meet the dimensional and access requirements for haulers, while providing easy access for the tenant spaces. The screening details will be provided in the subsequent ARB proceedings.

LANDSCAPING

SECTION 73.230 LANDSCAPING STANDARDS.

Purpose.

The purpose of this section is to establish standards for landscaping within Tualatin in order to enhance the environmental and aesthetic quality of the City:

- (1) By encouraging the retention and protection of existing trees and requiring the planting of trees in new developments;
- (2) By using trees and other landscaping materials to temper the effects of the sun, wind, noise, and air pollution.
- (3) By using trees and other landscaping materials to define spaces and the uses of specific areas; and
- (4) Through the use of trees and other landscaping materials as a unifying element within the urban environment. [Ord. 705-86, §6, Sept. 8, 1986]

Response: The Applicant is aware of the purpose of the landscaping standards and understands the impact that quality landscaping can have on the aesthetic experience of any development. The Landscape Planting Plan included with this master plan application demonstrates both the overall landscaping coverage of Nyberg Rivers, but also the careful selection of landscape materials for each area to create a sense of place that is inviting to any user. A specific palette of planting materials is provided with this master plan application. The tree planting plan is designed to provide shade and to define spaces between uses. The planting plan helps unify the design environment and minimize wind, noise and air pollution.

SECTION 73.240 LANDSCAPING GENERAL PROVISIONS.

- (1) The following standards are minimum requirements.
- (3) The minimum area requirement for landscaping for uses in CO, CR, CC, CG, ML and MG Planning Districts shall be fifteen (15) percent of the total land area to be developed, except within the Core Area Parking District, where the minimum area

requirement for landscaping shall be 10 percent. When a dedication is granted in accordance with the planning district provisions on the subject property for a fish and wildlife habitat area, the minimum area requirement for landscaping may be reduced by 2.5 percent from the minimum area requirement as determined through the AR process.

- (9) Yards adjacent to public streets, except as described in the Hedges Creek Wetlands Mitigation Agreement, [TDC 73.240\(7\)](#), shall be planted to lawn or live groundcover and trees and shrubs and be perpetually maintained in a manner providing a park-like character to the property as approved through the Architectural Review process.
- (10) Yards not adjacent to public streets or Low Density Residential (RL) or Manufacturing Park (MP) Planning Districts shall be planted with trees, shrubs, grass or other live groundcover, and maintained consistent with a landscape plan indicating areas of future expansion, as approved through the Architectural Review process.
- (11) Any required landscaped area shall be designed, constructed, installed, and maintained so that within three years the ground shall be covered by living grass or other plant materials. (The foliage crown of trees shall not be used to meet this requirement.) A maximum of 10% of the landscaped area may be covered with un-vegetated areas of bark chips, rock or stone. Disturbed soils are encouraged to be amended to an original or higher level of porosity to regain infiltration and stormwater storage capacity.
- (13) Landscape plans for required landscaped areas that include fences should carefully integrate any fencing into the plan to guide wild animals toward animal crossings under, over, or around transportation corridors. [Ord. 882-92 §15, 12/14/92; Ord. 890-93 §9, 4/12/93; Ord. 904-93 §53 and 54, 9/13/93; Ord. 993-94 §48, 11/28/94; Ord. 1025-99 §41, 7/26/99; Ord. 1035-99 §16, 11/8/99; Ord. 1070-01 §11, 4/9/01; Ord. 1070-01, 4/9/01; Ord. 1216-06, 7/24/06; Ord. 1224-06 §25, 11/13/06; Ord. 1321-11 §49, 4/25/11]

Response: Nyberg Rivers is located within the CC, CO, and RH planning districts. Therefore, the minimum landscape percentage is 15%. As the site does include a 6 acre natural area located at the north end of the site along the Tualatin River and landscaping is provided throughout the site within parking areas, central plazas, and as plantings within the setbacks and buffers, the total landscape area is 9.03 acres or 393,347 SF. This represents 28% of the overall site.

SECTION 73.250 TREE PRESERVATION.

- (1) Trees and other plant materials to be retained shall be identified on the landscape plan and grading plan.
- (2) During the construction process:
 - (a) The owner or the owner's agents shall provide above and below ground protection for existing trees and plant materials identified to remain.

- (b) Trees and plant materials identified for preservation shall be protected by chain link or other sturdy fencing placed around the tree at the drip line.
 - (c) If it is necessary to fence within the drip line, such fencing shall be specified by a qualified arborist as defined in [TDC 31.060](#).
 - (d) Neither top soil storage nor construction material storage shall be located within the drip line of trees designated to be preserved.
 - (e) Where site conditions make necessary a grading, building, paving, trenching, boring, digging, or other similar encroachment upon a preserved tree's drip-line area, such grading, paving, trenching, boring, digging, or similar encroachment shall only be permitted under the direction of a qualified arborist. Such direction must assure that the health needs of trees within the preserved area can be met.
 - (f) Tree root ends shall not remain exposed.
- (3) Landscaping under preserved trees shall be compatible with the retention and health of said tree.
 - (4) When it is necessary for a preserved tree to be removed in accordance with [TDC 34.210](#) the landscaped area surrounding the tree or trees shall be maintained and replanted with trees that relate to the present landscape plan, or if there is no landscape plan, then trees that are complementary with existing, nearby landscape materials. Native trees are encouraged
 - (5) Pruning for retained deciduous shade trees shall be in accordance with National Arborist Association "Pruning Standards For Shade Trees," revised 1979.
 - (6) Except for impervious surface areas, one hundred percent (100%) of the area preserved under any tree or group of trees retained in the landscape plan (as approved through the Architectural Review process) shall apply directly to the percentage of landscaping required for a development. [Ord. 904-93, §55, 9/13/93; Ord. 1224-06, §26, 11/13/06]

Response: Trees and landscaping areas to be retained with the proposed Nyberg Rivers development will be demarcated and shown on the ARB submittal documents. At this time, specific trees targeted for preservation have not been determined. During the construction process any trees identified for preservation will be protected with adequate fencing and root protection to ensure tree and root health.

SECTION 73.310 LANDSCAPE STANDARDS - COMMERCIAL, INDUSTRIAL, PUBLIC AND SEMI-PUBLIC USES.

- (1) A minimum 5-foot-wide landscaped area must be located along all building perimeters which are viewable by the general public from parking lots or the public right-of-way, excluding loading areas, bicycle parking areas and pedestrian egress/ingress locations. Pedestrian amenities such as landscaped plazas and

arcades may be substituted for this requirement. This requirement shall not apply where the distance along a wall between two vehicle or pedestrian access openings (such as entry doors, garage doors, carports and pedestrian corridors) is less than 8 feet.

- (2) Areas exclusively for pedestrian use that are developed with pavers, bricks, etc., and contain pedestrian amenities, such as benches, tables with umbrellas, children's play areas, shade trees, canopies, etc., may be included as part of the site landscape area requirement.
- (3) All areas not occupied by buildings, parking spaces, driveways, drive aisles, pedestrian areas or undisturbed natural areas shall be landscaped. [Ord. 882-92, §16, 12/14/92; Ord. 904-93, §58, 9/13/93]

Response: As noted in the Landscape Plan provided within the Master Plan document (Exhibit A), foundation and building landscaping will be planted with landscape material to complement the architectural style and soften building appearance within the overall Master Plan. Areas with predominate storefronts, multiple entryways, covered arcades, and/or outdoor seating areas provide landscaping between the drive aisle and pedestrian pathways to achieve a well vegetated urban environment. This is provided as an alternative to building foundation landscaping.

OFF-STREET PARKING LOT LANDSCAPING

SECTION 73.320 OFF-STREET PARKING LOT LANDSCAPING STANDARDS.

- (1) **General Provisions.** In addition to the goals stated in [TDC 73.110](#) and [73.140](#), the goals of the off-street parking lot standards are to create shaded areas in parking lots, to reduce glare and heat buildup, provide visual relief within paved parking areas, emphasize circulation patterns, reduce the total number of spaces, reduce the impervious surface area and stormwater runoff and enhance the visual environment. The design of the off-street parking area shall be the responsibility of the developer and should consider visibility of signage, traffic circulation, comfortable pedestrian access, and aesthetics. Trees shall not be cited as a reason for applying for or granting a variance on placement of signs.
- (2) **Application.** Off-street parking lot landscaping standards shall apply to any surface vehicle parking or circulation area.
[Ord. 904-93, §59, 9/13/93; Ord. 1224-06 §28, 11/13/06]

Response: Landscape islands are provided within the on-site, off-street parking areas. These landscape islands are spaced between every 8 parking stalls or are provided in landscape medians between the front end of parking stalls.

SECTION 73.340 OFF-STREET PARKING LOT AND LOADING AREA LANDSCAPING - COMMERCIAL, INDUSTRIAL, PUBLIC AND SEMI-PUBLIC USES, AND RESIDENTIAL AND MIXED USE RESIDENTIAL USES WITHIN THE CENTRAL DESIGN DISTRICT.

- (1) A clear zone shall be provided for the driver at ends of on-site drive aisles and at driveway entrances, vertically between a maximum of 30 inches and a minimum of 8 feet as measured from the ground level, except for parking structures and underground parking where this provision shall not apply.
- (2) Perimeter site landscaping of at least 5 feet in width shall be provided in all off-street parking and vehicular circulation areas (including loading areas). For conditional uses in multifamily residential planning districts the landscape width shall be at least 10 feet except for uses allowed by [TDC 40.030\(3\)](#), [40.030\(5\)\(j\)](#), [40.030\(5\)\(m\)](#), [40.030\(5\)\(n\)](#) and [41.030\(2\)](#).
 - (a) The landscape area shall contain:
 - (i) Deciduous trees an average of not more than 30 feet on center. The trees shall meet the requirements of [TDC 73.360\(7\)](#).
 - (ii) Plantings which reach a mature height of 30 inches in three years which provide screening of vehicular headlights year round.
 - (iii) Shrubs or ground cover, planted so as to achieve 90 percent coverage within three years.
 - (iv) Native trees and shrubs are encouraged.
 - (b) Where off-street parking areas on separate lots are adjacent to one another and are connected by vehicular access, the landscaped strips required in subsection (2) of this section are not required. [Ord. 882-92, §18, 12/14/92; Ord. 904-93, § 61, 9/13/93; Ord. 920-94, §19, 4/11/94; Ord. 1224-06 §30, 11/13/06]

Response: A 5-foot wide landscape area is provided along the perimeter of all off-street parking and vehicular circulation areas. All landscape areas do contain deciduous trees at a spacing no more than 30-feet on center, with ground plantings that reach a mature height of 30-inches in three years. Shrubs or groundcover will achieve 90 percent coverage within three years. A landscape planting plan and planting palette is included with this application demonstrating compliance with this criteria.

SECTION 73.360 OFF-STREET PARKING LOT LANDSCAPE ISLANDS - COMMERCIAL, INDUSTRIAL, PUBLIC, AND SEMI-PUBLIC USES.

- (1) A minimum of 25 square feet per parking stall shall be improved with landscape island areas. They may be lower than the surrounding parking surface to allow them to receive stormwater run-off and function as water quality facilities as well as parking lot landscaping. They shall be protected from vehicles by curbs, but the curbs may have spaces to allow drainage into the islands. They shall be dispersed throughout the parking area [see [TDC 73.380\(3\)](#)]. They shall be planted with groundcover or shrubs that will completely cover the island area within 3 years. They shall be planted with deciduous shade trees when needed to meet the parking lot shade tree requirements. Native plant materials are encouraged.

Landscape square footage requirements shall not apply to parking structures and underground parking.

- (2) Landscaped island areas with deciduous parking lot shade trees shall be a minimum of 5 feet in width (from inside of curb to curb).
- (3) A minimum of one deciduous shade tree shall be provided for every four (4) parking spaces to lessen the adverse impacts of glare, reduce heat from paved surfaces, and to emphasize circulation patterns. Required shade trees shall be uniformly distributed throughout the parking lot (see [TDC 73.380\(3\)](#)), except that within the Central Design District landscape islands and shade trees may be placed to frame views of the Tualatin Commons water feature or identified architectural focal elements. The trees shall meet the requirements of [TDC 73.360\(7\)](#). Parking lot shade tree requirements shall not apply to parking structures and underground parking.
- (4) Landscape islands shall be utilized at aisle ends to protect parked vehicles from moving vehicles and emphasize vehicular circulation patterns. Landscape island location requirements shall not apply to parking structures and under-ground parking.
- (5) Required plant material in landscape islands shall achieve 90 percent coverage within three years. Native shrubs and trees are encouraged.
- (6)
 - (a) Except as in (b) below, site access from the public street shall be defined with a landscape area not less than 5 feet in width on each side and extend 25 feet back from the property line for commercial, public, and semi-public development with 12 or more parking spaces and extend 30 feet back from the property line for industrial development, except for parking structures and under-ground parking which shall be determined through the Architectural Review process.
 - (b) In the Central Design District where driveway access is on local streets, not collectors or arterials, and the building(s) on the property is(are) less than 5,000 square feet in gross floor area, or parking is the only use on the property, site access from the public street shall be defined with a landscape area not less than 5 feet in width on each side and extend 5 feet back from the property line, except for parking structures and underground parking which shall be determined through the Architectural Review process.
- (7) Deciduous shade trees shall meet the following criteria:
 - (a) Reach a mature height of 30 feet or more;
 - (b) Cast moderate to dense shade in summer;
 - (c) Long lived, i.e., over 60 years;

- (d) Do well in an urban environment:
 - (i) Pollution tolerant.
 - (ii) Tolerant of direct and reflected heat.
- (e) Require little maintenance:
 - (i) Mechanically strong.
 - (ii) Insect- and disease-resistant.
 - (iii) Require little pruning.
- (f) Be resistant to drought conditions;
- (g) Be barren of fruit production. [Ord. 882-92, §20, 12/14/92; Ord. 904-93, §64, 9/13/93; Ord. 920-94, §20, 4/11/94; Ord. 945-95, §1, 5/8/95; Ord. 1224-06 §32, 11/13/06]

Response: The Applicant has provided the attached landscape plan which demonstrates that the site can be developed to meet the standards set forth above. The Applicant is proposing to utilize native plant materials within the site landscaping. A minimum of 5-foot landscape buffers are provided along all property lines and adjacent right-of-ways, while the proposed planting plan does include trees to meet the criteria outlined above. The Applicant has provided an approach for the how the landscaping will be provided onsite including specific details for how trees will be accommodated throughout the parking fields. Detailed conformance with the landscape requirements will be demonstrated at the time of Architectural Review. This includes specific calculations for interior parking lot landscaping and square footage summaries for parking lot landscape islands. Refer to the attached Landscape Planting Plan (Sheet L1.0 as part of Exhibit C) and the landscape plan elements outlined in the Master Plan document (Exhibit A).

SECTION 73.370 OFF-STREET PARKING AND LOADING.

- (1) General Provisions.
 - (a) At the time of establishment of a new structure or use, or change in use, or change in use of an existing structure, within any planning district of the City, off-street parking spaces, off-street vanpool and carpool parking spaces for commercial, institutional and industrial uses, off-street bicycle parking, and off-street loading berths shall be as provided in this and following sections, unless greater requirements are otherwise established by the conditional use permit or the Architectural Review process, based upon clear findings that a greater number of spaces are necessary at that location for protection of public health, safety and welfare or that a lesser number of vehicle parking spaces will be sufficient to carry out the

objectives of this section. In the Central Design District, the Design Guidelines of [TDC 73.610](#) shall be considered. In case of conflicts between guidelines or objectives in TDC Chapter 73, the proposal shall provide a balance.

- (b) At the time of enlargement of an existing multi-family residential, commercial, institutional or industrial structure or use, TDC 73.370 shall apply to the existing and enlarged structure or use.
- (c) Except where otherwise specified, the floor area measured shall be the gross floor area of the building primary to the function of the particular use of the property other than space devoted to off-street parking or loading.
- (d) Where employees are specified, the term shall apply to all persons, including proprietors, working on the premises during the peak shift.
- (e) Calculations to determine the number of required parking spaces and loading berths shall be rounded to the nearest whole number.
- (f) If the use of a property changes, thereby increasing off-street parking or loading requirements, the increased parking/loading area shall be provided prior to commencement of the new use.
- (g) Parking and loading requirements for structures not specifically listed herein shall be determined by the Community Development Director, based upon requirements of comparable uses listed.
- (h) When several uses occupy a single structure, the total requirements for off-street parking may be the sum of the requirements of the several uses computed separately or be computed in accordance with TDC 73.370(1)(m), Joint Use Parking.
- (i) Off-street parking spaces for dwellings shall be located on the same lot with the dwelling. Other required parking spaces may be located on a separate parcel, provided the parcel is not greater than five hundred (500) feet from the entrance to the building to be served, measured along the shortest pedestrian route to the building. The applicant must prove that the parking located on another parcel is functionally located and that there is safe vehicular and pedestrian access to and from the site. The parcel upon which parking facilities are located shall be in the same ownership as the structure.
- (j) Required parking spaces shall be available for the parking of operable passenger automobiles of residents, customers, patrons and employees and shall not be used for storage of vehicles or materials or for the parking of trucks used in conducting the business.
- (k) Institution of on-street parking, where none is previously provided, shall not be done solely for the purpose of relieving crowded parking lots in commercial or industrial planning districts.

- (l) **Parking facilities may be shared by users on adjacent parcels if the following standards are met:**
 - (i) **One of the parcels has excess parking spaces, considering the present use of the property; the other parcel lacks sufficient area for required parking spaces.**
 - (ii) **The total number of parking spaces meets the standards for the sum of the number of spaces which would be separately required for each use.**
 - (iii) **Legal documentation, to the satisfaction of the City Attorney, shall be submitted verifying permanent use of the excess parking area on one lot by patrons of the uses deficient in required parking area.**
 - (iv) **Physical access between adjoining lots shall be such that functional and reasonable access is actually provided to uses on the parcel deficient in parking spaces.**
 - (v) **Adequate directional signs shall be installed specifying the joint parking arrangement.**
 - (vi) **Areas in the Natural Resource Protection Overlay District, Other Natural Areas identified in [Figure 3-4](#) of the Parks and Recreation Master Plan, or a Clean Water Services Vegetated Corridor would be better protected.**

- (m) **Joint Use Parking. Joint use of parking spaces may occur where two or more separate developments or multiple uses in a development are able to jointly use some or all of the same required parking spaces because their parking demands occur at different times. Joint use of parking spaces may be allowed if the following standards are met:**
 - (i) **There shall be no substantial conflict in the principal operating hours of the buildings or uses for which the joint use parking is proposed. Future change of use, such as expansion of a building or establishment of hours of operation which conflict with or affect a joint use parking agreement are prohibited, unless approval is obtained through the Architectural Review process;**
 - (ii) **The joint use parking spaces shall be located no more than 500 feet from a building or use to be served by the joint use parking;**
 - (iii) **The number and location of parking spaces, hours of use and changes in operating hours of uses subject to joint use shall be approved through the Architectural Review process;**
 - (iv) **Legal documentation, to the satisfaction of the City Attorney, shall be submitted verifying the joint use parking between the separate developments. Joint use parking agreements may include**

provisions covering maintenance, liability, hours of use and cross easements; and

- (v) The City Attorney approved legal documentation shall be recorded by the applicant at the Washington or Clackamas County Recorder's Office and a copy of the recorded document submitted to the Planning Department prior to issuance of a building permit.
- (vi) Areas in the Natural Resource Protection Overlay District, Other Natural Areas identified in [Figure 3-4](#) of the Parks and Recreation Master Plan, or a Clean Water Services Vegetated Corridor would be better protected.
- (n) Bicycle parking facilities shall either be lockable enclosures in which the bicycle is stored, or secure stationary racks which accommodate a bicyclist's lock securing the frame and both wheels.
- (o) Each bicycle parking space shall be at least 6 feet long and 2 feet wide, and overhead clearance in covered areas shall be at least 7 feet, unless a lower height is approved through the Architectural Review process.
- (p) A 5-foot-wide bicycle maneuvering area shall be provided beside or between each row of bicycle parking. It shall be constructed of concrete, asphalt or a pervious surface such as pavers or grasscrete, but not gravel or woody material, and be maintained.
- (q) Access to bicycle parking shall be provided by an area at least 3 feet in width. It shall be constructed of concrete, asphalt or a pervious surface such as pavers or grasscrete, but not gravel or woody material, and be maintained.
- (r) Required bicycle parking shall be located in convenient, secure, and well-lighted locations approved through the Architectural Review process. Lighting, which may be provided, shall be deflected to not shine or create glare into street rights-of-way or fish and wildlife habitat areas.
- (s) Bicycle parking facilities may be provided inside a building in suitable secure and accessible locations.
- (t) Bicycle parking may be provided within the public right-of-way in the Core Area Parking District subject to approval of the City Engineer and provided it meets the other requirements for bicycle parking.
- (u) Bicycle parking areas and facilities shall be identified with appropriate signing as specified in the Manual on Uniform Traffic Control Devices (MUTCD) (latest edition). At a minimum, bicycle parking signs shall be located at the main entrance and at the location of the bicycle parking facilities.

- (v) Required bicycle parking spaces shall be provided at no cost to the bicyclist, or with only a nominal charge for key deposits, etc. This shall not preclude the operation of private for-profit bicycle parking businesses.
- (w) Parking on existing residential, commercial and industrial development may be redeveloped as a transit facility as a way to encourage the development of transit supportive facilities such as bus stops and pullouts, bus shelters and park and ride stations. Parking spaces converted to such uses in conjunction with the transit agency and approved through the Architectural Review process will not be required to be replaced.
- (x) Required vanpool and carpool parking shall meet the 9-foot parking stall standards in [Figure 73-1](#) and be identified with appropriate signage.

Response: The applicant is aware of the vehicle and bicycle parking requirements listed above. As this project represents a redevelopment of the existing site, new parking requirements are triggered. The total number of off-street parking stalls provided for the general shopping center use is 1,299 stalls. Bicycle parking is provided on-site and all requirements will be addressed at the time of ARB submittal.

(2) Off-Street Parking Provisions.

- (a) The following are the minimum and maximum requirements for off-street motor vehicle parking in the City, except for minimum parking requirements for the uses in TDC 73.370(2)(a) (Residential Uses: iii, iv, v, vi, vii; Places of Public Assembly: I, ii, iv; Commercial Amusements: I, ii; and Commercial: I, ii, xi, xii, xiv) within the Core Area Parking District (CAPD). Minimum standards for off-street motor vehicle parking for the uses in 73.370(2) (a) Residential Uses: iii, iv, v, vi, vii; Places of Public Assembly: I, ii, iv; Commercial Amusements: I, ii; and Commercial: I, ii, xi, xii, xiv in the CAPD are in TDC 73.370(2)(b). The maximum requirements are divided into Zone A and Zone B, as shown on the Tualatin Parking Zone Map, [Figure 73-3](#). The following are exempt from calculation of maximum parking requirements: parking structures; fleet parking; parking for vehicles for sale, lease or rent; car/vanpool parking; dedicated valet parking; and user-paid parking.

USE	MINIMUM MOTOR VEHICLE PARKING REQUIREMENT	MAXIMUM MOTOR VEHICLE PARKING REQUIREMENT	BICYCLE PARKING REQUIREMENT	PERCENTAGE OF BICYCLE PARKING TO BE COVERED
(iii) Shopping center (over 100,000 sq. ft. of gross floor area)	4.1 spaces per 1,000 sq. ft. of gross floor area	Zone A: 5.1 spaces per 1,000 sq. ft. gross floor area Zone B: 6.2 spaces per 1,000 sq. ft. gross floor area	0.50 space per 1,000 sq. ft. of gross floor area	50

Response: For the sake of parking stall accounting, the overall Nyberg Rivers commercial area is classified as a shopping center with greater than 100,000 SF of gross floor area. Therefore, the parking requirement of 4.1 spaces per 1,000 SF of gross floor area is applied. With a maximum permissible building area of 307,000 SF, the minimum number of spaces required is 1,259, while the total parking stalls provided is 1,299 stalls. Therefore, the minimum parking stall requirement is met. 154 bicycle parking spaces are required on-site. Exact locations of the bicycle parking stalls will be addressed at the time of ARB review.

SECTION 73.380 OFF-STREET PARKING LOTS.

A parking lot, whether an accessory or principal use, intended for the parking of automobiles or trucks, shall comply with the following:

- (1) Off-street parking lot design shall comply with the dimensional standards set forth in [Figure 73-1](#) of this section, except for parking structures and underground parking where stall length and width requirements for a standard size stall shall be reduced by .5 feet and vehicular access at the entrance if gated shall be a minimum of 18 feet in width.

Response: All off-street parking stalls are designed to comply with the dimensional standards set forth in Figure 73-1.

- (2) Parking stalls for sub-compact vehicles shall not exceed 35 percent of the total parking stalls required by [TDC 73.370\(2\)](#). Stalls in excess of the number required by [TDC 73.370\(2\)](#) can be sub-compact stalls.

Response: Sub-compact parking stalls are provided and marked on the attached Site Plan (Exhibit C). With 1,259 stalls required to meet the minimum parking requirement,

440 of those spaces may be compact. The applicant does provide sub-compact spaces throughout the site, but well below the 35-percent threshold.

- (3) Off-street parking stalls shall not exceed eight continuous spaces in a row without a landscape separation, except for parking structures and underground parking. For parking lots within the Central Design District that are designed to frame views of the central water feature or identified architectural focal elements as provided in [TDC 73.350\(3\)](#), this requirement shall not apply and the location of parking lot landscape islands shall be determined through the Architectural Review process.

Response: Specific locations of parking lot landscape islands will be determined at the time of ARB submittal and review. Generally, the proposed Landscape Planting Plan (Sheet L1.0, Exhibit C) provided with this application does show parking lot landscaping to meet the intent of the standard.

- (4) Parking lot drive aisles shall be constructed of asphalt or concrete, including pervious concrete. Parking stalls shall be constructed of asphalt or concrete, or a pervious surface such as pavers or grasscrete, but not gravel or woody material. Drive aisles and parking stalls shall be maintained adequately for all-weather use and drained to avoid water flow across sidewalks. Pervious surfaces such as pervious concrete, pavers and grasscrete, but not gravel or woody material, are encouraged for parking stalls in or abutting the Natural Resource Protection Overlay District, Other Natural Areas identified in [Figure 3-4](#) of the Parks and Recreation Master Plan, or in a Clean Water Services Vegetated Corridor.

Response: Parking lot drive aisles will be constructed of asphalt or concrete, while parking stalls will also be constructed of asphalt or concrete. The maintenance of these areas will be conducted by the Nyberg Rivers maintenance staff.

- (5) Artificial lighting, which may be provided, shall be deflected to not shine or create glare in a residential planning district, an adjacent dwelling, street right-of-way in such a manner as to impair the use of such way or a Natural Resource Protection Overlay District, Other Natural Areas identified in [Figure 3-4](#) of the Parks and Recreation Master Plan, or a Clean Water Services Vegetated Corridor.

Response: Artificial lighting will be deflected to not shine or create glare into any residential planning district, street right-of-way or adjacent dwelling. A site Photometric Plan will be provided with the ARB submittal package to address these requirements.

- (8) Service drives to off-street parking areas shall be designed and constructed to facilitate the flow of traffic, provide maximum safety of traffic access and egress, and maximum safety of pedestrians and vehicular traffic on the site.

Response: Service drive aisles will be designed and constructed to facilitate the flow of traffic, provide maximum safety of traffic access and egress, while promoting the maximum safety of pedestrians and vehicular traffic on the site.

- (9) Parking bumpers or wheel stops or curbing shall be provided to prevent cars from encroaching on the street right-of-way, adjacent landscaped areas, or adjacent pedestrian walkways.

Response: Generally, curbing will be provided to prevent cars from encroaching on to the street right-of-way, adjacent landscaped areas and adjacent pedestrian walkways.

- (10) Disability parking spaces and accessibility shall be provided in accordance with applicable federal and state requirements.

Response: ADA compliant spaces are provided nearest the building entrances in those parking areas closest to the primary entrances of the tenant spaces. These stalls are provided in accordance with federal and state requirements.

- (11) On-site drive aisles without parking spaces, which provide access to parking areas with regular spaces or with a mix of regular and sub-compact spaces, shall have a minimum width of 22 feet for two-way traffic and 12 feet for one-way traffic. On-site drive aisles without parking spaces, which provide access to parking areas with only sub-compact spaces, shall have a minimum width of 20 feet for two-way traffic and 12 feet for one-way traffic. [Ord. 882-92, §22, 12/14/92; Ord. 904-93, §68, 69 and 70, 9/13/93; Ord. 920-94, §22, 4/11/94; Ord. 956-96, §38, 1/8/96; Ord. 1224-06 §34, 11/13/06]

Response: All proposed on-site drive aisles are dimensioned to be 24-feet or greater, surpassing the minimum width requirement of 22-feet.

SECTION 73.390 OFF-STREET LOADING FACILITIES.

- (1) The minimum number of off-street loading berths for commercial, industrial, public and semi-public uses is as follows:

Square Feet of Floor Area	Number of Berths
Less than 5,000	0
5,000 - 25,000	1
25,000 - 60,000	2
60,000 and over	3

- (2) Loading berths shall conform to the following minimum size specifications.

- (a) Commercial, public and semi-public uses of 5,000 to 25,000 square feet shall be 12' x 25' and uses greater than 25,000 shall be 12' x 35'

- (b) Industrial uses - 12' x 60'
 - (c) Berths shall have an unobstructed height of 14'
 - (d) Loading berths shall not use the public right-of-way as part of the required off-street loading area.
- (3) Required loading areas shall be screened from public view from public streets and adjacent properties by means of sight-obscuring landscaping, walls or other means, as approved through the Architectural Review process.
 - (4) Required loading facilities shall be installed prior to final building inspection and shall be permanently maintained as a condition of use.
 - (6) The off-street loading facilities shall in all cases be on the same lot or parcel as the structure they are intended to serve. In no case shall the required off-street loading spaces be part of the area used to satisfy the off-street parking requirements.
 - (7) Subject to Architectural Review approval, the Community Development Director may allow the standards in this Section to be relaxed within the Central Design District, where a dense mix of uses is desirable in close proximity, pedestrian circulation is strongly emphasized, and the orientation of structures around a central water feature virtually eliminates the possibility of reserving any side of a building solely for truck access. Adjustments may include, but are not limited to, reduction in the number of loading berths required, adjustment of loading berth size specifications and right-of-way restrictions, shared loading berths and maneuvering areas for use by more than one building, alteration or elimination of screening requirements, and requirements for maintenance of berths in a clean and visually appealing condition. [Ord. 882-92, §23, 12/14/92; Ord. 956-96, §39, 1/8/96]

Response: Off-street loading facilities are located behind the central buildings, therefore screening these areas from public view. These on-site loading areas provide semi-truck access into and through the site, with truck turning radii to allow semi-trucks up to 62-feet in length. There are more than three (3) loading areas shown on the Site Plan, surpassing the 3 space minimum required by code. All berths meet the 14-foot height requirement.

SECTION 73.400 ACCESS.

- (1) The provision and maintenance of vehicular and pedestrian ingress and egress from private property to the public streets as stipulated in this Code are continuing requirements for the use of any structure or parcel of real property in the City of Tualatin. No building or other permit shall be issued until scale plans are presented that show how the ingress and egress requirement is to be fulfilled. If the owner or occupant of a lot or building changes the use to which the lot or building is put, thereby increasing ingress and egress requirements, it shall be unlawful and a violation of this code to begin or maintain such altered use until the required increase in ingress and egress is provided.

- (2) Owners of two or more uses, structures, or parcels of land may agree to utilize jointly the same ingress and egress when the combined ingress and egress of both uses, structures, or parcels of land satisfies their combined requirements as designated in this code; provided that satisfactory legal evidence is presented to the City Attorney in the form of deeds, easements, leases or contracts to establish joint use. Copies of said deeds, easements, leases or contracts shall be placed on permanent file with the City Recorder.
- (3) **Joint and Cross Access.**
- (a) Adjacent commercial uses may be required to provide cross access drive and pedestrian access to allow circulation between sites.
- (b) A system of joint use driveways and cross access easements may be required and may incorporate the following:
- (i) a continuous service drive or cross access corridor extending the entire length of each block served to provide for driveway separation consistent with the access management classification system and standards.
 - (ii) a design speed of 10 mph and a maximum width of 24 feet to accommodate two-way travel aisles designated to accommodate automobiles, service vehicles, and loading vehicles;
 - (iii) stub-outs and other design features to make it visually obvious that the abutting properties may be tied in to provide cross access via a service drive;
 - (iv) a unified access and circulation system plan for coordinated or shared parking areas.
- (c) Pursuant to this section, property owners may be required to:
- (i) Record an easement with the deed allowing cross access to and from other properties served by the joint use driveways and cross access or service drive;
 - (ii) Record an agreement with the deed that remaining access rights along the roadway will be dedicated to the city and pre-existing driveways will be closed and eliminated after construction of the joint-use driveway;
 - (iii) Record a joint maintenance agreement with the deed defining maintenance responsibilities of property owners;
 - (iv) If (i-iii) above involve access to the state highway system or county road system, ODOT or the county shall be contacted and shall approve changes to (i-iii) above prior to any changes.

- (4) Requirements for Development on Less than the Entire Site.
- (a) To promote unified access and circulation systems, lots and parcels under the same ownership or consolidated for the purposes of development and comprised of more than one building site shall be reviewed as one unit in relation to the access standards. The number of access points permitted shall be the minimum number necessary to provide reasonable access to these properties, not the maximum available for that frontage. All necessary easements, agreements, and stipulations shall be met. This shall also apply to phased development plans. The owner and all lessees within the affected area shall comply with the access requirements.
- (b) All access must be internalized using the shared circulation system of the principal commercial development or retail center. Driveways should be designed to avoid queuing across surrounding parking and driving aisles.
- (5) Lots that front on more than one street may be required to locate motor vehicle accesses on the street with the lower functional classification as determined by the City Engineer.
- (6) Except as provided in [TDC 53.100](#), all ingress and egress shall connect directly with public streets. [Ord. 882-92, § 24,12/14/92]
- (7) Vehicular access for residential uses shall be brought to within 50 feet of the ground floor entrances or the ground floor landing of a stairway, ramp or elevator leading to dwelling units.
- (8) To afford safe pedestrian access and egress for properties within the City, a sidewalk shall be constructed along all street frontage, prior to use or occupancy of the building or structure proposed for said property. The sidewalks required by this section shall be constructed to City standards, except in the case of streets with inadequate right-of-way width or where the final street design and grade have not been established, in which case the sidewalks shall be constructed to a design and in a manner approved by the City Engineer. Sidewalks approved by the City Engineer may include temporary sidewalks and sidewalks constructed on private property; provided, however, that such sidewalks shall provide continuity with sidewalks of adjoining commercial developments existing or proposed. When a sidewalk is to adjoin a future street improvement, the sidewalk construction shall include construction of the curb and gutter section to grades and alignment established by the City Engineer.
- (9) The standards set forth in this Code are minimum standards for access and egress, and may be increased through the Architectural Review process in any particular instance where the standards provided herein are deemed insufficient to protect the public health, safety, and general welfare.
- (11) Minimum Access Requirements for Commercial, Public and Semi-Public Uses.

In the Central Design District, when driveway access is on local streets, not collectors or arterials and the building(s) on the property is(are) less than 5,000 square feet in gross

floor area, or parking is the only use on the property, ingress and egress shall not be less than 24 feet. In all other cases, ingress and egress for commercial uses shall not be less than the following:

Required Parking Spaces	Minimum Number Required	Minimum Pavement Width	Minimum Pavement Walkways, Etc.
1-99	1	32 feet for first 50 feet from ROW, 24' thereafter	Curbs required; walkway 1 side only
100-249	2	32 feet for first 50 feet from ROW, 24' thereafter	Curbs required;; walkway 1 side only
Over 250	As required by City Engineer	As required by City Engineer	As required by City Engineer

(13) One-way Ingress or Egress.

When approved through the Architectural Review process, one-way ingress or egress may be used to satisfy the requirements of Subsections (7), (8), and (9). However, the hard surfaced pavement of one-way drives shall not be less than 16 feet for multi-family residential, commercial, or industrial uses.

(14) Maximum Driveway Widths and Other Requirements.

- (a) Unless otherwise provided in this chapter, maximum driveway widths shall not exceed 40 feet.
- (b) Except for townhouse lots, no driveways shall be constructed within 5 feet of an adjacent property line, except when two adjacent property owners elect to provide joint access to their respective properties, as provided by Subsection (2).
- (c) There shall be a minimum distance of 40 feet between any two adjacent driveways on a single property unless a lesser distance is approved by the City Engineer.

(15) Distance between Driveways and Intersections.

Except for single-family dwellings, the minimum distance between driveways and intersections shall be as provided below. Distances listed shall be measured from the stop bar at the intersection.

- (a) At the intersection of collector or arterial streets, driveways shall be located a minimum of 150 feet from the intersection.

- (b) At the intersection of two local streets, driveways shall be located a minimum of 30 feet from the intersection.
 - (c) If the subject property is not of sufficient width to allow for the separation between driveway and intersection as provided, the driveway shall be constructed as far from the intersection as possible, while still maintaining the 5-foot setback between the driveway and property line as required by TDC 73.400(14)(b).
 - (d) When considering a public facilities plan that has been submitted as part of an Architectural Review plan in accordance with [TDC 31.071\(6\)](#), the City Engineer may approve the location of a driveway closer than 150 feet from the intersection of collector or arterial streets, based on written findings of fact in support of the decision. The written approval shall be incorporated into the decision of the City Engineer for the utility facilities portion of the Architectural Review plan under the process set forth in [TDC 31.071](#) through [31.077](#).
- (16) Vision Clearance Area.
- (a) Local Streets - A vision clearance area for all local street intersections, local street and driveway intersections, and local street or driveway and railroad intersections shall be that triangular area formed by the right-of-way lines along such lots and a straight line joining the right-of-way lines at points which are 10 feet from the intersection point of the right-of-way lines, as measured along such lines (see [Figure 73-2](#) for illustration).
 - (b) Collector Streets - A vision clearance area for all collector/arterial street intersections, collector/arterial street and local street intersections, and collector/arterial street and railroad intersections shall be that triangular area formed by the right-of-way lines along such lots and a straight line joining the right-of-way lines at points which are 25 feet from the intersection point of the right-of-way lines, as measured along such lines. Where a driveway intersects with a collector/arterial street, the distance measured along the driveway line for the triangular area shall be 10 feet (see [Figure 73-2](#) for illustration).
 - (c) Vertical Height Restriction - Except for items associated with utilities or publicly owned structures such as poles and signs and existing street trees, no vehicular parking, hedge, planting, fence, wall structure, or temporary or permanent physical obstruction shall be permitted between 30 inches and 8 feet above the established height of the curb in the clear vision area (see [Figure 73-2](#) for illustration). [Ord. 895-93 §3, 5/24/93; Ord. 945-95, 5/8/95; Ord. 1025-99, §7, 7/26/99; Ord. 1026-99 §97, 8/9/99; Ord. 1103-02, 3/25/02; Ord. 1096-02, 1/28/02]

Response: Vehicular and pedestrian access into and through the site is demonstrated in the Site Plan Set (Exhibit C) and Master Plan document (Exhibit A) submitted with this application. As the site will be developed with all access points under single ownership, no joint or cross access agreements or easements are requested. As

shown on the Transportation Plan for the Master Plan document, primary vehicle and truck circulation patterns are shown, as well as the primary vehicular access points.

TDC 74: PUBLIC IMPROVEMENT REQUIREMENTS

SECTION 74.010 PURPOSE.

The City's Community Plan sets forth the requirements for providing adequate transportation and utility systems to serve the community's present and future needs. Land development without adequate transportation and utility systems will adversely affect the overall economic growth of the City and cause undue damage to the public health and welfare of its citizens. Consequently, the City finds that it is in the public interest to require land development to meet the following improvement requirements. [Ord. 895-93, § 14, 5/24/93]

Response: The Applicant incorporates by reference the findings above addressing the adequacy of transportation facilities serving the site.

IMPROVEMENTS

SECTION 74.110 PHASING OF IMPROVEMENTS.

The applicant may build the development in phases. If the development is to be phased the applicant shall submit a phasing plan to the City Engineer for approval with the development application. The timing and extent or scope of public improvements and the conditions of development shall be determined by the City Council on subdivision applications and by the City Engineer on other development applications.

Response: There is no proposed phasing planned for the Nyberg Rivers commercial master plan, although future development areas are shown on the attached Master Plan Site Plan for two parcels located along SW Martinazzi Avenue and the High Density Residential district located in the northwest corner of the site.

SECTION 74.120 PUBLIC IMPROVEMENTS.

- (1) Except as specially provided, all public improvements shall be installed at the expense of the applicant. All public improvements installed by the applicant shall be constructed and guaranteed as to workmanship and material as required by the Public Works Construction Code prior to acceptance by the City. No work shall be undertaken on any public improvement until after the construction plans have been approved by the City Engineer and a Public Works Permit issued and the required fees paid.

Response: The Applicant is aware that all public improvements shall be installed at the expense of the Applicant. And those public improvements will be constructed

and guaranteed as to workmanship and material as required by the Public Works Construction Code prior to acceptance by the City

SECTION 74.130 PRIVATE IMPROVEMENTS.

All private improvements shall be in-stalled at the expense of the applicant. The property owner shall retain maintenance responsibilities over all private improvements.

Response: The Applicant is aware that all private improvements shall be installed at the expense of the Applicant and Maintenance of those improvements will be under the responsibility of the applicant.

SECTION 74.140 CONSTRUCTION TIMING.

- (1) All the public improvements required under this chapter shall be completed and accepted by the City prior to the issuance of a Certificate of Occupancy; or, for subdivision and partition applications, in accordance with the requirements of the Subdivision regulations.
- (2) All private improvements required under this chapter shall be approved by the City prior to the issuance of a Certificate of Occupancy; or for subdivision and partition applications, in accordance with the requirements of the Subdivision regulations.

Response: The Applicant is aware that the public and private improvements shall be completed and accepted prior to the issuance of a Certificate of Occupancy.

RIGHT-OF-WAY

SECTION 74.210 MINIMUM STREET RIGHT-OF-WAY WIDTHS.

The width of streets in feet shall not be less than the width required to accommodate a street improvement needed to mitigate the impact of a proposed development. In cases where a street is required to be improved according to the standards of the TDC, the width of the right-of-way shall not be less than the minimums indicated in [TDC Chapter 11](#), Transportation Plan.

- (2) For development applications other than subdivisions and partitions, wherever existing or future streets adjacent to property proposed for development are of inadequate right-of-way width, the additional right-of-way necessary to comply with the Transportation Element of the Tualatin Community Plan shall be dedicated to the City for use by the public prior to issuance of any building permit for the proposed development. This right-of-way dedication shall be for the full width of the property abutting the roadway and, if required by the City Engineer, additional dedications shall be provided for slope and utility easements if deemed necessary.

- (4) If the City Engineer deems that it is impractical to acquire the additional right-of-way as required in subsections (1)-(3) of this section from both sides of the center-line in equal amounts, the City Engineer may require that the right-of-way be dedicated in a manner that would result in unequal dedication from each side of the road. This requirement will also apply to slope and utility easements as discussed in [TDC 74.320](#) and [74.330](#). The City Engineer's recommendation shall be presented to the City Council in the preliminary plat approval for subdivisions and partitions, and in the recommended decision on all other development applications, prior to finalization of the right-of-way dedication requirements.
- (5) Whenever a proposed development is bisected by an existing or future road or street that is of inadequate right-of-way width according to [TDC Chapter 11](#), Transportation Plan, additional right-of-way shall be dedicated from both sides or from one side only as determined by the City Engineer to bring the road right-of-way in compliance with this section.
- (6) When a proposed development is adjacent to or bisected by a street proposed in [TDC Chapter 11](#), Transportation Plan and no street right-of-way exists at the time the development is proposed, the entire right-of-way as shown in [TDC Chapter 11](#) shall be dedicated by the applicant. The dedication of right-of-way required in this subsection shall be along the route of the road as determined by the City.

Response: The Applicant is aware that additional right-of-way may need to be dedicated in order to facilitate street improvements along adjacent roadways that serve the Nyberg Rivers site. Based on discussion with City Transportation Engineers, some additional ROW dedication is required for the proposed improvements to SW Nyberg Street to accommodate the 350-foot westbound right-turn lane, as well as a bicycle lane for a portion of the property that fronts SW Nyberg Street.

EASEMENTS AND TRACTS

SECTION 74.310 GREENWAY, NATURAL AREA, BIKE, AND PEDESTRIAN PATH DEDICATIONS AND EASEMENTS.

- (1) Areas dedicated to the City for Greenway or Natural Area purposes or easements or dedications for bike and pedestrian facilities during the development application process shall be surveyed, staked and marked with a City approved boundary marker prior to acceptance by the City.
- (2) For subdivision and partition applications, the Greenway, Natural Area, bike, and pedestrian path dedication and easement areas shall be shown to be dedicated to the City on the final subdivision or partition plat prior to approval of the plat by the City; or
- (3) For all other development applications, Greenway, Natural Area, bike, and pedestrian path dedications and easements shall be submitted to the City Engineer; building permits shall not be issued for the development prior to

acceptance of the dedication or easement by the City. [Ord. 933-94 §50, 11/28/94; Ord. 979-97 §52, 7/14/97; Ord. 1026-99 §98, 8/9/99].

Response: As shown on the attached Site Plan, the Applicant proposes a “Shared Pathway Easement” that will allow for future development and the extension of the Tualatin River Trail at a later date. This easement will be accepted by the City prior to issuance of building permits.

SECTION 74.320 SLOPE EASEMENTS.

- (1) The applicant shall obtain and convey to the City any slope easements determined by the City Engineer to be necessary adjacent to the proposed development site to support the street improvements in the public right-of-way or accessway or utility improvements required to be constructed by the applicant.
- (2) For subdivision and partition applications, the slope easement dedication area shall be shown to be dedicated to the City on the final subdivision or partition plat prior to approval of the plat by the City; or
- (3) For all other development applications, a slope easement dedication shall be submitted to the City Engineer; building permits shall not be issued for the development prior to acceptance of the easement by the City. [Ord. 933-94, § 51, 11/28/94]

Response: The Applicant is aware that slope easements determined by the City Engineer may be necessary to support the street improvements in the public ROW.

SECTION 74.330 UTILITY EASEMENTS.

- (1) Utility easements for water, sanitary sewer and storm drainage facilities, telephone, television cable, gas, electric lines and other public utilities shall be granted to the City.
- (4) For development applications other than subdivisions and partitions, and for both on-site and off-site easement areas, a utility easement shall be granted to the City; building permits shall not be issued for the development prior to acceptance of the easement by the City. The City may elect to exercise eminent domain and condemn necessary off-site public utility easements at the applicant's request and expense. The City Council shall determine when condemnation proceedings are to be used.
- (5) The width of the public utility easement shall meet the requirements of the Public Works Construction Code. All subdivisions and partitions shall have a 6-foot public utility easement adjacent to the street and a 5-foot public utility easement adjacent to all side and rear lot lines. [Ord. 933-94, § 52, 11/28/94]

Response: The Applicant is aware that utility easements are likely to be required for water, sanitary sewer and storm draining facilities. While there are existing easements, it is likely that additional utility easements will be required for the additional infrastructure proposed as a part of the Nyberg Rivers commercial

redevelopment project and those easements will be accepted by the City prior to issuance of building permits.

SECTION 74.340 WATERCOURSE EASEMENTS.

- (1) Where a proposed development site is traversed by or adjacent to a watercourse, drainage way, channel or stream, the applicant shall provide a storm water easement, drainage right-of-way, or other means of preservation approved by the City Engineer, conforming substantially with the lines of the watercourse. The City Engineer shall determine the width of the easement, or other means of preservation, required to accommodate all the requirements of the Surface Water Management Ordinance, existing and future storm drainage needs and access for operation and maintenance.
- (2) For subdivision and partition applications, any watercourse easement dedication area shall be shown to be dedicated to the City on the final subdivision or partition plat prior to approval of the plat by the City; or
- (3) For all other development applications, any watercourse easement shall be executed on a dedication form submitted to the City Engineer; building permits shall not be issued for the development prior to acceptance of the easement by the City.
- (4) The storm water easement shall be sized to accommodate the existing water course and all future improvements in the drainage basin. There may be additional requirements as set forth in [TDC Chapter 72](#), Greenway and Riverbank Protection District, and the Surface Water Management Ordinance. Water quality facilities may require additional easements as described in the Surface Water Management Ordinance. [Ord. 933-94, § 53, 11/28/94]

Response: The Applicant is not proposing a subdivision, nor is there any known watercourse or drainage way that is located on the property that would necessitate an easement per the standards set forth above.

SECTION 74.350 TRACTS.

A dedicated tract or easement will be required when access to public improvements for operation and maintenance is required, as determined by the City Engineer. Access for maintenance vehicles shall be constructed of an all-weather driving surface capable of carrying a 50,000-pound vehicle. The width of the tract or easement shall be 15-feet in order to accommodate City maintenance vehicles. In subdivisions and partitions, the tract shall be dedicated to the City on the final plat. In any other development, an access easement shall be granted to the City and recorded prior to issuance of a building permit. [Ord. 933-94, § 54, 11/28/94]

Response: The applicant will be dedicating proper easements with the Nyberg Rivers redevelopment project. These easements will include dedications for utilities and shared pathways.

TRANSPORTATION

SECTION 74.410 FUTURE STREET EXTENSIONS.

- (1) Streets shall be extended to the proposed development site boundary where necessary to:
 - (a) give access to, or permit future development of adjoining land;
 - (b) provide additional access for emergency vehicles;
 - (c) provide for additional direct and convenient pedestrian, bicycle and vehicle circulation;
 - (d) eliminate the use of cul-de-sacs except where topography, barriers such as railroads or freeways, existing development, or environmental constraints such as major streams and rivers prevent street extension.
 - (e) eliminate circuitous routes. The resulting dead end streets may be approved without a turnaround. A reserve strip may be required to preserve the objectives of future street extensions.

- (2) Proposed streets shall comply with the general location, orientation and spacing identified in the Local Streets Plan, [TDC 11.630](#), [Figure 11-1](#) and [Figure 11-3](#).
 - (a) Streets proposed as part of new residential or mixed residential/commercial developments shall comply with the following standards:
 - (i) full street connections with spacing of no more than 530 feet between connections, except where prevented by barriers;
 - (ii) bicycle and pedestrian accessway easements where full street connections are not possible, with spacing of no more than 330 feet, except where prevented by barriers;
 - (iii) limiting cul-de-sacs and other closed-end street systems to situations where barriers prevent full street extensions; and
 - (iv) allowing cul-de-sacs and closed-end streets to be no longer than 200 feet or with more than 25 dwelling units, except for streets stubbed to future developable areas.
 - (b) Streets proposed as part of new industrial or commercial development shall comply with [TDC 11.630\(2\)](#) and [Figure 11-1](#).

- (3) During the development application process, the location, width, and grade of streets shall be considered in relation to existing and planned streets, to topographical conditions, to public convenience and safety, and to the proposed

use of the land to be served by the streets. The arrangement of streets in a subdivision shall either:

- (a) provide for the continuation or appropriate projection of existing streets into surrounding areas; or
 - (b) conform to a street plan approved or adopted by the City to meet a particular situation where topographical or other conditions make continuance of or conformance to existing streets impractical.
- (4) The City Engineer may require the applicant to submit a street plan showing all existing, proposed, and future streets in the area of the proposed development.
- (5) The City Engineer may require the applicant to participate in the funding of future off-site street extensions when the traffic impacts of the applicant's development warrant such a condition. [Ord. 933-94 §55, 11/28/94; Ord. 1026-99 §99, 8/9/99; Ord. 1103-02, 3/25/02]

Response: The Applicant has submitted a street plan with this application narrative. The street plan shows improved access to the site in compliance with this criteria and permits development of adjoining land. As shown on the Site Plan, the Applicant is proposing a signalized intersection at that SW Martinazzi & SW Seneca Street intersection. Street "A" on the Site Plan will be dedicated and extended from Boones Ferry Road into the site, connecting to Seneca and Nyberg Streets. An access easement will be dedicated with the Street "A" extension in order to provide future access to the Future Development Area 4. As shown on the Site Plan and in the findings above, the Site Plan provides direct and convenient pedestrian, bicycle and vehicle access through the site. New sidewalks and streets are planned through the site, connecting with the surrounding vehicle, pedestrian and bicycle network. These proposed streets and drive aisles do meet the design standards identified TDC 11.630, Figure 11-1 and Figure 11-3 and do consider the context of existing, adjacent streets.

The Site Plan is sensitively designed to facilitate development of adjoining properties through the location of uses and street extensions.

The findings provided earlier in this narrative addressing the street, pedestrian and bike improvements are incorporated herein by reference.

SECTION 74.420 STREET IMPROVEMENTS.

When an applicant proposes to develop land adjacent to an existing or proposed street, including land which has been excluded under [TDC 74.220](#), the applicant should be responsible for the improvements to the adjacent existing or proposed street that will bring the improvement of the street into conformance with the Transportation Plan, and the City's Public Works Construction Code, subject to the following provisions:

- (1) For any development proposed within the City, roadway facilities within the right-of-way described in [TDC 74.210](#) shall be improved to standards as set out in the Public Works Construction Code.

- (2) The required improvements may include the rebuilding or the reconstruction of any existing facilities located within the right-of-way adjacent to the proposed development to bring the facilities into compliance with the Public Works Construction Code.
- (3) The required improvements may include the construction or rebuilding of off-site improvements which are identified to mitigate the impact of the development.
- (4) Where development abuts an existing street, the improvement required shall apply only to that portion of the street right-of-way located between the property line of the parcel proposed for development and the centerline of the right-of-way, plus any additional pavement beyond the centerline deemed necessary by the City Engineer to ensure a smooth transition between a new improvement and the existing roadway (half-street improvement). Additional right-of-way and street improvements and off-site right-of-way and street improvements may be required by the City to mitigate the impact of the development. The new pavement shall connect to the existing pavement at the ends of the section being improved by tapering in accordance with the Public Works Construction Code.
- (5) If additional improvements are required as part of the Access Management Plan of the City, [TDC Chapter 75](#), the improvements shall be required in the same manner as the half-street improvement requirements.
- (6) All required street improvements shall include curbs, sidewalks with appropriate buffering, storm drainage, street lights, street signs, street trees, and, where designated, bikeways and transit facilities.
- (7) For subdivision and partition applications, the street improvements required by TDC Chapter 74 shall be completed and accepted by the City prior to signing the final subdivision or partition plat, or prior to releasing the security provided by the applicant to assure completion of such improvements or as otherwise specified in the development application approval.
- (8) For development applications other than subdivisions and partitions, all street improvements required by this section shall be completed and accepted by the City prior to the issuance of a Certificate of Occupancy.
- (9) In addition to land adjacent to an existing or proposed street, the requirements of this section shall apply to land separated from such a street only by a railroad right-of-way.
- (10) Streets within, or partially within, a proposed development site shall be graded for the entire right-of-way width and constructed and surfaced in accordance with the Public Works Construction Code.
- (11) Existing streets which abut the proposed development site shall be graded, constructed, reconstructed, surfaced or repaired as necessary in accordance with the Public Works Construction Code and [TDC Chapter 11](#), Transportation Plan.

- (12) Sidewalks with appropriate buffering shall be constructed along both sides of each internal street and at a minimum along the development side of each external street in accordance with the Public Works Construction Code.
- (13) The applicant shall comply with the requirements of the Oregon Department of Transportation (ODOT), Tri-Met, Washington County and Clackamas County when a proposed development site is adjacent to a roadway under any of their jurisdictions, in addition to the requirements of this chapter.
- (14) The applicant shall construct any required street improvements adjacent to parcels excluded from development, as set forth in [TDC 74.220](#) of this chapter.
- (15) Except as provided in [TDC 74.430](#), whenever an applicant proposes to develop land with frontage on certain arterial streets and, due to the access management provisions of [TDC Chapter 75](#), is not allowed direct access onto the arterial, but instead must take access from another existing or future public street thereby providing an alternate to direct arterial access, the applicant shall be required to construct and place at a minimum street signage, a sidewalk, street trees and street lights along that portion of the arterial street adjacent to the applicant's property. The three certain arterial streets are S.W. Tualatin-Sherwood Road, S.W. Pacific Highway (99W) and S.W. 124th Avenue. In addition, the applicant may be required to construct and place on the arterial at the intersection of the arterial and an existing or future public non-arterial street warranted traffic control devices (in accordance with the Manual on Uniform Traffic Control Devices, latest edition), pavement markings, street tapers and turning lanes, in accordance with the Public Works Construction Code.
- (16) The City Engineer may determine that, although concurrent construction and placement of the improvements in (14) and (15) of this section, either individually or collectively, are impractical at the time of development, the improvements will be necessary at some future date. In such a case, the applicant shall sign a written agreement guaranteeing future performance by the applicant and any successors in interest of the property being developed. The agreement shall be subject to the City's approval.
- (17) Intersections should be improved to operate at a level of service of at least D and E for signalized and unsignalized intersections, respectively. [Ord. 933-94 §56, 11/28/94; Ord. 1026-99 §100, 8/9/99; Ord.1103-02, 3/25/02; Ord. 1224-06 §36, 11/13/06]

Response: The scope of the traffic report and required level of service analysis and street standards applicable in the TIA were reviewed and approved by all of the relevant jurisdictions prior to commencing the TIA analysis. The analysis demonstrates that all signalized and unsignalized intersections that are impacted at more than a de minimis level will continue to operate at LOS D or E, respectively consistent with this criteria.

The Applicant is aware that street improvements are needed along adjacent roadways that serve the Nyberg Rivers site. Based on discussion with City Transportation Engineers, some additional ROW dedication is required for the

proposed improvements to SW Nyberg Street to accommodate the 350-foot westbound right-turn lane, as well as a bicycle lane for a portion of the property that fronts SW Nyberg Street. The proposed access to the Martinazzi Avenue/SW Seneca Street intersection and the "Street A" connection between the site and Boones Ferry Road will likely require street improvements, although those specific improvements have not been identified at this time. Generally, Street A will be designed to the Collector roadway standard, with two-lanes, a bicycle lane, landscape strip, and pedestrian sidewalk.

SECTION 74.440 STREETS, TRAFFIC STUDY REQUIRED.

- (1) The City Engineer may require a traffic study to be provided by the applicant and furnished to the City as part of the development approval process as provided by this Code, when the City Engineer determines that such a study is necessary in connection with a proposed development project in order to:
 - (a) Assure that the existing or proposed transportation facilities in the vicinity of the proposed development are capable of accommodating the amount of traffic that is expected to be generated by the proposed development, and/or
 - (b) Assure that the internal traffic circulation of the proposed development will not result in conflicts between on-site parking movements and/or on-site loading movements and/or on-site traffic movements, or impact traffic on the adjacent streets.
- (2) The required traffic study shall be completed prior to the approval of the development application.
- (3) The traffic study shall include, at a minimum:
 - (a) an analysis of the existing situation, including the level of service on adjacent and impacted facilities.
 - (b) an analysis of any existing safety deficiencies.
 - (c) proposed trip generation and distribution for the proposed development.
 - (d) projected levels of service on adjacent and impacted facilities.
 - (e) recommendation of necessary improvements to ensure an acceptable level of service for roadways and a level of service of at least D and E for signalized and unsignalized intersections respectively, after the future traffic impacts are considered.
 - (f) The City Engineer will determine which facilities are impacted and need to be included in the study.
 - (g) The study shall be conducted by a registered engineer.

(4) **The applicant shall implement all or a portion of the improvements called for in the traffic study as determined by the City Engineer. [Ord. 1103-02, 3/25/02]**

Response: The required TIA was scoped with the City and County and was completed by Kittelson and Associates. That TIA is included with this application submittal and that TIA addresses all of the above requirements while demonstrating that the proposed development will not impact and will in fact improve in many instances, the existing transportation infrastructure. The mitigation to improve traffic efficiency is also noted in the TIA. Those improvements include:

- A new roadway connection to SW Boones Ferry Road (shown as "Street A" in Figure 2 of the TIA) that includes sidewalks.
- An enhanced site-access driveway to SW Nyberg Road that will better accommodate vehicular queuing and demand.
- A potential future (assuming the City desires to move forward) new site-access connection to SW Martinazzi Avenue that aligns across from SW Seneca Street. This connection would be the Seneca Street extension envisioned in the Town Center Plan. Prior to the City making a decision on any new SW Street Seneca alignment, the redevelopment site plan preserves this connection opportunity in the present or future.
- The preservation of east-west and north-south travel ways that will provide vehicular and pedestrian access between Street A, the Seneca Street alignment/extension, and enhanced access to SW Nyberg Road.
- New sidewalks along the enhanced site-access driveway to SW Nyberg Road that provide pedestrian connections to the integrated site circulation network.
- New bikeway connections along the perimeter of the site.
- Closure of the existing SW 75th Avenue site-access driveway to SW Nyberg Road to minimize turning movement conflicts, allow for construction of a westbound right-turn lane at SW Nyberg Road/signalized site driveway, and to improve the interchange access spacing conditions along SW Nyberg Road.
- A new 350-foot westbound right-turn lane constructed on SW Nyberg Road

The site design also facilitates connections to surrounding properties and does not preclude the development of other transportation facilities consistent with the TSP. These commitments by the applicant will work to create a more efficient and coordinated transportation system within Nyberg Rivers and the City Center.

SECTION 74.450 BIKEWAYS AND PEDESTRIAN PATHS.

- (1) Where proposed development abuts or contains an existing or proposed bikeway or pedestrian path, as set forth in [TDC Chapter 11](#), Transportation Plan, the City may require that a bikeway or pedestrian path be constructed, and an easement or dedication provided to the City.
- (2) Where required, bikeways and pedestrian paths shall be provided as follows:
 - (a) Bike and pedestrian paths shall be constructed and surfaced in accordance with the Public Works Construction Code.
 - (b) The applicant shall install the striping and signing of the bike lanes and shared roadway facilities, where designated. [Ord. 933-94, § 57, 11/28/94]

Response: The Applicant is proposing to dedicate a shared pathway easement for the future build out of a pedestrian and bicycle path along the Tualatin River Trail network. That shared pathway easement is located at the northern end of Nyberg Rivers, within the conservation area along the south side of the Tualatin River. The Applicant is also proposing to construct two north-south connections through the site; the first bisects the site running north from the main entrance off of Nyberg Street through the site, between buildings proposed buildings 1030 and 1040 connecting in with the planned Tualatin River Trail. The second north south connection is located within the western portions of the site and connects Seneca Street to proposed Street "A" and the planned Tualatin River Trail. All pathways will be constructed in accordance with the Public Works Construction Code.

SECTION 74.470 STREET LIGHTS.

- (1) Street light poles and luminaries shall be installed in accordance with the Public Works Construction Code.
- (2) The applicant shall submit a street lighting plan for all interior and exterior streets on the proposed development site prior to issuance of a Public Works Permit.

Response: The Applicant is aware of the street lighting provision. Street lighting and a Photometric Plan will be provided at the time of ARB submittal.

UTILITIES

SECTION 74.610 WATER SERVICE.

- (1) Water lines shall be installed to serve each property in accordance with the Public Works Construction Code. Water line construction plans shall be submitted to the City Engineer for review and approval prior to construction.
- (2) If there are undeveloped properties adjacent to the subject site, public water lines shall be extended by the applicant to the common boundary line of these

properties. The lines shall be sized to provide service to future development, in accordance with the City's Water System Master Plan, [TDC Chapter 12](#).

- (3) As set forth is [TDC Chapter 12](#), Water Service, the City has three water service levels. All development applicants shall be required to connect the proposed development site to the service level in which the development site is located. If the development site is located on a boundary line between two service levels the applicant shall be required to connect to the service level with the higher reservoir elevation. The applicant may also be required to install or provide pressure reducing valves to supply appropriate water pressure to the properties in the proposed development site. [Ord. 933-94, § 59, 11/28/94]

Response: The subject property is bounded by I-5 to the east, the Tualatin River to the north, Nyberg Street to the south and City owned property that fronts Martinazzi Avenue to the west. There are currently water lines in Martinazzi Avenue providing service to the adjacent City owned properties. Likewise the existing apartment development located north is connected to the water system in Boones Ferry Road. The Applicant has included a proposed water system plan that will provide access to water for domestic as well as fire protection for the proposed Master Plan. All proposed and existing buildings will be served by the proposed water system. The proposed water system onsite will extend a portion of the public water line with a 10 foot easement to serve the proposed buildings F-100, G-100, and H-100. At the property line the public water line will change to a private water line (proposed double check valve assembly to differentiate the private and public). This private portion of the water line will extend around the site to provide service to proposed buildings J-100, M-100, N-100, 1040, 1010, and 1005. A combined compound meter/double-check detector assembly is proposed to be installed at one end of the private loop with a double-check detector assembly proposed at the other public connection. Fire hydrants and FDC's have been placed around the proposed buildings for fire protection. All new buildings have been proposed as with fire sprinkler systems. A Water Plan is enclosed with this application for proposed layouts.

SECTION 74.620 SANITARY SEWER SERVICE.

- (1) Sanitary sewer lines shall be installed to serve each property in accordance with the Public Works Construction Code. Sanitary sewer construction plans and calculations shall be submitted to the City Engineer for review and approval prior to construction.
- (2) If there are undeveloped properties adjacent to the proposed development site which can be served by the gravity sewer system on the proposed development site, the applicant shall extend public sanitary sewer lines to the common boundary line with these properties. The lines shall be sized to convey flows to include all future development from all up stream areas that can be expected to drain through the lines on the site, in accordance with the City's Sanitary Sewer System Master Plan, [TDC Chapter 13](#). [Ord. 933-94, § 60, 11/28/94]

Response: All sanitary sewer will be conveyed through an on-site sanitary sewer system. The proposed sanitary sewer system will reroute a portion of the public sewer line with a 15 foot easement to ensure sanitary service to the property in the southeast corner of the site and the acquired ODOT land (Proposed Building F-100, G-100, and H-100). A proposed main private sanitary line that serves proposed buildings J-100, M-100, N-100, 1005, 1010, and 1040 will run north of the proposed buildings and connect into the existing public sanitary sewer line. Grease interceptors will be located prior to the public sanitary sewer line connection for any proposed restaurant or building tenant requiring grease interceptors. A Sanitary Plan is enclosed with this application for proposed layouts.

SECTION 74.630 STORM DRAINAGE SYSTEM.

- (1) Storm drainage lines shall be installed to serve each property in accordance with City standards. Storm drainage construction plans and calculations shall be submitted to the City Engineer for review and approval prior to construction.
- (2) The storm drainage calculations shall confirm that adequate capacity exists to serve the site. The discharge from the development shall be analyzed in accordance with the City's Storm and Surface Water Regulations.
- (3) If there are undeveloped properties adjacent to the proposed development site which can be served by the storm drainage system on the proposed development site, the applicant shall extend storm drainage lines to the common boundary line with these properties. The lines shall be sized to convey expected flows to include all future development from all up stream areas that will drain through the lines on the site, in accordance with the Tualatin Drainage Plan in [TDC Chapter 14](#). [Ord. 933-94, § 61, 11/28/94; Ord. 952-95, § 2, 10/23/95]

Response: The existing stormwater system onsite is comprised of a public storm sewer mainline and multiple private collection laterals feeding into that public line. The public line is encompassed within a 15 foot public easement running just north of the existing retail buildings and then heading south to serve the property in the southeast corner. Treatment for the existing site is limited to a few Contech stormfilter catch basins spread throughout the site. The remaining site is captured in sumped, trapped catch basins and conveyed directly to the public line. The public line outfalls into the Tualatin River just north of the site. The Applicant has included a Stormwater Drainage Report with this submittal that provides drainage calculations consistent with this requirement. As previously state the site is surrounded by public facilities, natural features or property already committed to development. The proposed Master Plan is consistent with these requirements.

SECTION 74.640 GRADING.

- (1) Development sites shall be graded to minimize the impact of storm water runoff onto adjacent properties and to allow adjacent properties to drain as they did before the new development.
- (2) A development applicant shall submit a grading plan showing that all lots in all portions of the development will be served by gravity drainage from the building crawl spaces; and that this development will not affect the drainage on adjacent properties. The City Engineer may require the applicant to remove all excess material from the development site.

Response: The Applicant has included a grading plan as part of this submittal. The Applicant is proposing to re-grade the vast majority of the site in order to direct stormwater into appropriate basins for subsequent treatment. Proposed new grades on the site range from a low point of approximately 125 msl near the northwest corner of the site to a high point of approximately 136 msl near the eastern boundary of the site.

SECTION 74.650 WATER QUALITY, STORM WATER DETENTION AND EROSION CONTROL.

The applicant shall comply with the water quality, storm water detention and erosion control requirements in the Surface Water Management Ordinance. If required:

- (1) On subdivision and partition development applications, prior to approval of the final plat, the applicant shall arrange to construct a permanent on-site water quality facility and storm water detention facility and submit a design and calculations indicating that the requirements of the Surface Water Management Ordinance will be satisfied and obtain a Stormwater Connection Permit from Clean Water Services; or
- (2) On all other development applications, prior to issuance of any building permit, the applicant shall arrange to construct a permanent on-site water quality facility and storm water detention facility and submit a design and calculations indicating that the requirements of the Surface Water Management Ordinance will be met and obtain a Stormwater Connection Permit from Clean Water Services.
- (3) For on-site private and regional non-residential public facilities, the applicant shall submit a stormwater facility agreement, which will include an operation and maintenance plan provided by the City, for the water quality facility for the City's review and approval. The applicant shall submit an erosion control plan prior to issuance of a Public Works Permit. No construction or disturbing of the site shall occur until the erosion control plan is approved by the City and the required measures are in place and approved by the City. [Ord. 952-95, § 3, 10/23/95; Ord. 1070-01, 4/9/01; Ord. 1327-11 §1; 6/27/11]

Response: The proposed project includes the construction of public and private storm sewer lines. All on-site surface water will be captured, conveyed and treated through an on-site stormwater system before discharged into the public system. Public storm lines have been designed for Street “A” and SW Seneca Street extension with treatment from Contech stormfilter structures. Additionally, a public storm line with a 15-foot easement has been proposed behind the proposed retail buildings (1005, 1010, and 1040). The public line then runs south to serve the property in the southeast corner of the site and the acquired ODOT land (Proposed buildings F-100 and G-100). A private storm line will be extended to the north for connections to proposed buildings J-100, M-100, and N-100. The storm service for existing buildings “A”, “B”, and “C” will remain in place, but will be retrofit with Contech stormfilter structures to treat the existing impervious area.

The remainder of the site will be captured in sumped catch basins and conveyed to Contech stormfilter structures. Sumped catch basins and Contech stormfilter structures are an approved pretreatment and treatment device per the City of Tualatin and Clean Water Services. A Storm Drainage Plan and Drainage Report are enclosed with this application for proposed layouts and more information. Operation and maintenance of the storm drainage areas will be the responsibility of Nyberg Rivers property management.

SECTION 74.660 UNDERGROUND.

- (1) All utility lines including, but not limited to, those required for gas, electric, communication, lighting and cable television services and related facilities shall be placed underground. Surface-mounted transformers, surface-mounted connection boxes and meter cabinets may be placed above ground. Temporary utility service facilities, high capacity electric and communication feeder lines, and utility transmission lines operating at 50,000 volts or above may be placed above ground. The applicant shall make all necessary arrangements with all utility companies to provide the underground services. The City reserves the right to approve the location of all surface-mounted transformers.**
- (2) Any existing overhead utilities may not be upgraded to serve any proposed development. If existing overhead utilities are not adequate to serve the proposed development, the applicant shall, at their own expense, provide an underground system. The applicant shall be responsible for obtaining any off-site deeds and/or easements necessary to provide utility service to this site; the deeds and/or easements shall be submitted to the City Engineer for acceptance by the City prior to issuance of the Public Works Permit.**

Response: The Applicant is aware of this provision and will underground all utilities as required. Any surface mounted transformers or connection boxes will feature landscape or structural screening to limit visual impacts.

SECTION 74.670 EXISTING STRUCTURES.

- (1) Any existing structures requested to be retained by the applicant on a proposed development site shall be connected to all available City utilities at the expense of the applicant.
- (2) The applicant shall convert any existing overhead utilities serving existing structures to underground utilities, at the expense of the applicant.
- (3) The applicant shall be responsible for continuing all required street improvements adjacent to the existing structure, within the boundaries of the proposed development site.

Response: Several existing structures are proposed to be retained as a part of the Nyberg Rivers redevelopment. The Applicant will ensure that those structures are connected to all City utilities and that those utilities are placed underground.

SECTION 74.705 STREET TREE REMOVAL PERMIT.

- (1) A person who desires to remove or destroy a tree, as defined in [TDC 31.060](#), in or upon public right-of-way shall make application to the Operations Director on City forms.
- (2) The applicant must provide:
 - (a) the applicant's name and contact information and if applicable that of the applicant's contractor;
 - (b) the number and species of all street trees the applicant desires to remove;
 - (c) a clear description of the street trees' the applicant desires to remove;
 - (d) the date of removal;
 - (e) the reason(s) for removal; and
 - (f) other information as the Operations Director deems necessary.
- (3) Upon the Operations Director approving the removal of a street tree, the applicant or designated contractor shall replace each removed tree on a one-for-one basis by fulfilling the following requirements:
 - (a) Remove both the tree and stump prior to planting a replacement tree, or request the City to remove the tree and stump and pay the applicable fee(s) established in [TDC 74.706](#); and
 - (b) Replace the removed tree by planting a species of street tree permitted by Schedule A of the TDC Chapter 74 within the time period specified in writing by the Operations Director; or, the applicant may request within

sixty (60) days of the permit approval date that the City replace the street tree and pay the applicable fee(s) established in [TDC 74.706](#). If an applicant opts for the City to plant the replacement tree, the Operations Department may plant the tree on its usual tree-planting schedule. Planting done by the applicant or designated contractor shall comply with all applicable TDC sections and any additional requirements imposed by the Operations Director.

- (c) The applicant shall comply with all applicable TDC sections and additional requirements imposed by the Operations Director. The Operations Director may:
- (d) waive the one-for-one replacement requirement if he or she determines that the replacement would:
 - (i) conflict with public improvements or utility facilities, including but not limited to fire hydrants, water meters and pipes, lighting fixtures, traffic control signs; private improvements or utility facilities – including but not limited to driveways and power, gas, telephone, cable television lines; or, minimum vision clearance;
 - (ii) interfere with the existing canopy of adjacent trees, the maturation of the crown of the proposed replacement tree, or both;
 - (A) cause a conflict by planting trees too close to each other, hurting their health;
 - (iii) limit the selection of species from Schedule A: and;
 - (iv) direct how to plant replacement tree(s).
- (e) a person who fails to comply with TDC 74.705 shall pay an enforcement fee and a restoration fee to the City of Tualatin, as set forth in [TDC 34.220\(3\)](#), in addition to civil penalties in [TDC 31.111](#). [Ord. 963-96, § 9, 6/24/96. Ord. 1079-01, § 2, 7/23/01; Ord. 1279-09 §3, 3/23/09]

Response: The applicant is aware of the Street Tree Removal Permit requirements. No street trees are proposed to be removed as part of this application. If any street trees need to be removed in the future, the Applicant will comply with these standards. Proposed new street trees are included in the Landscape Planting Plan included with this application under Exhibit C.

SECTION 74.720 PROTECTION OF TREES DURING CONSTRUCTION.

- (1) During the erection, repair, alteration or removal of a building or structure, it is unlawful for the person in charge of such erection, repair, alteration or removal to leave a tree in or upon a public right-of-way in the vicinity of the building or

structure without a good and sufficient guard or protectors to prevent injury to the tree arising out of or by reason of such erection, repair, alteration or removal.

- (2) Excavations and driveways shall not be placed within six feet of a tree in or upon a public right-of-way without written permission from the City Engineer. During excavation or construction, the person shall guard the tree within six feet and all building material or other debris shall be kept at least four feet from any tree. [Ord. 963-96, § 9, 6/24/96]

Response: The Applicant is aware of the requirements for tree protection during construction. Proper protection will be shown on the Erosion Control and Grading Plan submitted as a part of the ARB application.

SECTION 74.765 STREET TREE SPECIES AND PLANTING LOCATIONS.

All trees, plants or shrubs planted in the right-of-way of the City shall conform in species and location and in accordance with the street tree plan in Schedule A. If the Operations Director determines that none of the species in Schedule A is appropriate or finds appropriate a species not listed, the Director may substitute an unlisted species. [Ord. 963-96, § 9, 6/24/96; Ord. 1279-09 §7, 3/23/09]

Response: The Applicant has presented a landscape plan that includes approved trees from the Schedule A: Street Tree Species list. As included under Exhibit C, the proposed Planting Plan includes Oak, Hawthorne, Cedar, and Ash trees throughout the street frontage and interior landscape areas.

TDC CHAPTER 75: ACCESS MANAGEMENT ON ARTERIAL STREETS

SECTION 75.010 PURPOSE.

The purpose of this chapter is to promote the development of safe, convenient and economic transportation systems and to preserve the safety and capacity of the street system by limiting conflicts resulting from uncontrolled driveway access, street intersections, and turning movements while providing for appropriate access for all properties. [Ord. 635-84, §43, 6/11/1984; Ord. 982-97, § 2, 8/4/1997; Ord. 1103-02, 3/25/02]

Response: As noted in the TIA, the applicant is proposing to remove vehicle access to SW 75th Avenue from SW Nyberg Street in order to improve access management along SW Nyberg in compliance with this criterion. The TIA and findings above demonstrate that the plan includes a safe, convenient and economic transportation system that preserves the safety and capacity of the street system while limiting conflicts from uncontrolled access.

SECTION 75.030 FREEWAYS, EXPRESSWAYS AND ARTERIALS DEFINED.

This section shall apply to all City, County and State public streets, roads and highways within the City and to all properties that abut these streets, roads and highways.

- (1) Access shall be in conformance with TDC Chapter 73 unless otherwise noted below.

(2) **Freeways, Expressways and Arterials Designated.**
For the purposes of this chapter the following are freeways, expressways and arterials:

- (f) Nyberg Street, from its intersection with Tualatin-Sherwood Road east to 65th Avenue, including the I-5 Interchange;
- (i) Boones Ferry Road at all points located within the City of Tualatin Planning Area;
- (m) Martinazzi Avenue from Boones Ferry Road south to Sagert Street;

Response: The project directly abuts SW Nyberg Street, a Major Arterial, and provides secondary access to both SW Martinazzi and Boones Ferry Road.

SECTION 75.050 APPROVAL PROCESS FOR ACCESS ONTO ARTERIALS, AND APPEAL PROVISIONS.

- (1) All requests for access onto arterials shall be reviewed by the City Engineer and follow the process described in TDC 31.074 through TDC 31.078 unless it is processed in conjunction with an application requiring a public hearing by the City Council. Based on provisions of this chapter and of the procedure described in TDC 31.074 through TDC 31.078, the City Engineer shall approve, approve with conditions, or reject the request for access in writing, stating the reasons for his or her decision.
- (2) Notice of the City Engineer's decision shall be distributed in accordance with TDC 31.074. The applicant shall be responsible for preparing the list of property owners within the notification area in the manner provided by TDC 31.071. The City Engineer's decision shall be final 14 calendar days after the date the notice of the decision is distributed unless within the 14 calendar the City Engineer receives a request for review of the decision. Requests for review shall be submitted in accordance with TDC 31.076 and a hearing conducted in accordance with TDC 31.077. [§75.05(3) Re-pealed by Ord. 743-88, §29 & 34, 3/28/88; Ord. 982-97, §6, 8/4/97; Ord. 96-07, 5/12/97; Ord. 1096-02 §38, 1/28/02]

Response: The proposed Nyberg Rivers Master Plan will utilize an existing access point onto SW Nyberg Street. The Applicant is also proposing to remove an existing access point on Nyberg Street (75th Street). The Applicant is providing an easement for future connection to Street "A" to allow for future access management along Boones Ferry. The Applicant is also proposing that the connection from Street "A" to Boones ferry be constructed as a right-in/right-out improvement consistent with these requirements. As noted in the TIA provided with this application, several transportation improvements are proposed that will work to enhance access management and vehicle circulation and efficiency. Those findings are again incorporated herein by reference.

SECTION 75.060 EXISTING DRIVEWAYS AND STREET INTERSECTIONS.

- (1) Existing driveways with access onto arterials on the date this chapter was originally adopted shall be allowed to remain. If additional development occurs on

proper-ties with existing driveways with access onto arterials then this chapter applies and the entire site shall be made to conform with the requirements of this chapter.

- (2) The City Engineer may restrict existing driveways and street intersections to right-in and right-out by construction of raised median barriers or other means. [Ord. 635-84, §48, 6/11/84; Ord. 982-97, §7, 8/4/97]

Response: The proposed Nyberg Rivers Master Plan will utilize an existing driveway onto SW Nyberg Street. As noted in the TIA provided with this application, several transportation improvements are proposed that will work to enhance access management and vehicle circulation and efficiency.

SECTION 75.070 NEW INTERSECTIONS.

Except as shown on , all new intersections with arterials shall have a minimum spacing of ½ mile between intersections. [Ord. 635-84, §49, 6/11/84]

Response: The Applicant is proposing to provide a new extension, Street "A" that will connect with Boones Ferry Road as depicted within the City's TSP. The proposed location of the connection was arrived at based on site distance, topography and the conceptual alignment depicted in the City's TSP.

SECTION 75.080 ALTERNATE ACCESS.

Except as provided in TDC 75.090 all properties which abut an arterial and another road or street shall not have access on the arterial. [Ord. 635-84, §50, 6/11/84]

Response: The only access points on to public streets from Nyberg Rivers are Major Arterials. Therefore, there are no alternate access points on to secondary roads. More detail concerning the existing and planned transportation system is set forth on the TIA included within this submittal.

SECTION 75.090 INTERIM ACCESS.

When a property abuts a freeway, expressway or arterial and a future street shown on Map 75-1, or abuts or bisects the property, the City Engineer may approve an interim access on the arterial subject to the following conditions:

- (1) The City Engineer finds that at the current time the construction of the new street shown on Map 75-1 is impractical due to costs of right-of-way acquisition.
- (2) The property owner receiving interim access dedicates the right-of-way for the new street as shown on Map 75-1 if it would be on the property.

- (3) At such time as the City Engineer finds that it is practical to construct a new street as shown on Map 75-1, the property owner agrees to pay for or construct its fair share of the new street when it is practical.
- (4) At such time as the new street as shown on Map 75-1 is constructed, the interim access shall be closed and no longer used. The cost of this closure shall be borne by the property owner.
- (5) In granting the interim access the property owner may be required to share said interim access with adjacent properties.
- (6) The interim access shall be constructed in a manner to make it as efficient as possible. Improvements required as part of the interim access may include:
 - (a) A left turn lane.
 - (b) A right turn lane.
 - (c) Driveways constructed at street intersections to provide for truck turning movement.
 - (d) Dedication of additional right-of-way on the arterial.
 - (e) Installation of traffic control signals.
 - (f) Limitation of new driveways to right turn in, right turn out movements by construction of raised median barriers or other means.
- (7) Any interim access approved in accordance with this chapter shall be set forth in the form of a written agreement, approved by the City Attorney. The agreement shall be verified by the owner in the manner provided for deeds and restrictions on real property. The agreement shall bind the parties thereto as well as their heirs, successors in interest and assigns and shall not be modified without the express written approval of the City. [Ord. 635-84, §51, 6/11/84, §75.090(7); Ord. 743-88, §30, 3/28/88; Ord. 1103-02, 3/25/02]

Response: The Applicant is not seeking interim or temporary access onto any arterial roads. The proposed redevelopment will make use of existing access driveways onto Major Arterials.

SECTION 75.100 EXCEPTIONS.

If the City Engineer finds that it is physically impossible for a property to receive access from any other street or road than an arterial as defined in TDC 75.030 and that the property cannot physically be served by any new street as shown on Map 75-1 or any logical extension of or addition thereto, the City Engineer may grant a permanent access directly to an arterial. In doing so the City Engineer may impose conditions on the construction of said access including, but not limited to:

- (1) Dedication of additional right-of-way on the arterial.
- (2) Creation of a joint access.
- (3) Construction of left turn lanes.

- (4) Construction of right turn lanes.
- (5) Installation of traffic signals.
- (6) Limitation of access to right turn in, right turn out by construction of raised median barriers or other means. [Ord. 635-84, §52, 6/11/84]

Response: The Applicant is not currently seeking an arterial access exception. The proposed redevelopment will make use of existing access driveways onto Major Arterials.

SECTION 75.110 NEW STREETS.

- (1) New streets designed to serve as alternatives to direct, parcel by parcel, access onto arterials are shown on Map 75-1. These streets are shown as corridors with the exact location determined through the partition, subdivision, public works permit or Architectural Review process. Unless modified by the City Council by the procedure set out below, these streets will be the only new intersections with arterials in the City. See map for changes
- (2) Specific alignment of a new street may be altered by the City Engineer upon finding that the street, in the proposed alignment, will carry out the objectives of this chapter to the same, or a greater degree as the described alignment, that access to adjacent and nearby properties is as adequately maintained and that the revised alignment will result in a segment of the Tualatin road system which is reasonable and logical.
- (3) The City Council may include additional streets on Map 75-1 through the plan amendment procedure. In addition to other required findings, the City Council must find that the addition is necessary to implement the objectives of this chapter. [Ord. 635-84, §53, 6/11/84; Ord. 743-88, §31, 3/28/88; Ord. 975-97, §3, 5/12/97; Ord. 1023-99, §11, 6/28/99]

Response: The Applicant is proposing to provide a new extension, Street “A” that will connect with Boones Ferry Road as depicted within the City’s TSP. The proposed location of the connection was arrived at based on site distance, topography and the conceptual alignment depicted in the City’s TSP. Consistent with these criteria, the streets on the TSP are shown as corridors only with the exact location determined through public works or architectural review process. The location of Street A is consistent with the corridor established in the TSP and will serve the stated purpose of the loop road connecting Nyberg Street and Boones Ferry Road.

SECTION 75.120 EXISTING STREETS.

The following list describes in detail the freeways, expressways and arterials as defined in TDC 75.030 with respect to access. Recommendations are made for future changes in accesses and location of future accesses. These recommendations are examples of possible solutions and shall not be construed as limiting the City’s authority to change

or impose different conditions if additional studies result in different recommendations from those listed below.

S.W. NYBERG STREET

Tualatin-Sherwood Road to 65th Avenue:

On the south side between Fred Meyer and I-5 Freeway any development shall be served by the Fred Meyer driveway aligned with the K-Mart driveway on the north side and shall not be granted any access to Nyberg Street.

On the east side of I-5 Freeway on the north side of the road between the Sweetbrier Inn and the Trailer Park of Portland, any additional development or redevelopment shall remove existing driveways and be limited to two street accesses, the driveway for Forest Rim and a driveway on the west side of 7035 SW Nyberg Street (2S124A/2505).

On the south side of Nyberg Street the accesses to Texaco and Lazyboy will be relocated to align with the access on the north side of Nyberg Street. The westside Nyberg Retail access may be limited to right-in, right-out. The Meridian Veterinary Hospital and 7-11 driveways may remain, or be closed or combined if redevelopment occurs, or be changed as needed when the 65th/Nyberg Street intersection is reconfigured. There will be no new additional driveways created in this section of roadway.

Response: The proposed redevelopment at Nyberg Rivers will utilize the existing Fred Meyer/K-Mart driveway to provide primary access into the Nyberg Rivers commercial center in compliance with this criterion. The K-Mart driveway will be improved for safer and more efficient access into the existing site as defined in the TIA..

BOONES FERRY ROAD

North City Limits to Tualatin River:

All existing driveways will remain. No new driveways will be permitted.

Tualatin River to Tualatin Road:

Between the River and Martinazzi Avenue on the south side, the access for the apartments (2S1 24B/1500) will be closed and converted over to the Loop Road. The Loop Road may have a right-in, right-out connection to Boones Ferry Road between the river and Martinazzi Avenue. On the south side of Boones Ferry Road between Martinazzi Avenue and the driveway for the White Lot (old Lot C), any development or redevelopment shall take access over the White Lot or from Martinazzi Avenue. Between the White lot and 84th Avenue, all properties shall have combined accesses resulting in only one access on Boones Ferry Road. Between 84th Avenue and Tualatin Road on the south side, any redevelopment shall result in no driveways onto Boones Ferry Road and access shall be taken from 84th Avenue or Seneca Street.

Response: An access easement from Street "A" is proposed to serve the high-density residential apartments located in the northwest portion of Nyberg Rivers. This access easement will provide access onto the future Loop Road, which will provide right-in, right-out access onto Boones Ferry Road.

MARTINAZZI AVENUE

Boones Ferry Road to Seneca Street:

On the west side, any redevelopment on the Doyle (old Silvey) property (2S1 24BC/1500, 1503) or the Halstin (old post office property) (2S1 24BC/1502) shall result in combining these two driveways into one driveway on Martinazzi Avenue, or the Halstin property shall take access from the White public parking lot (old Lot C) to Boones Ferry Road. On the east side the existing driveway shall be removed and access shall be taken off of the Loop Road.

Seneca Street to Nyberg Street:

No driveways shall be permitted. The raised center median prohibiting left turns in this area shall remain until driveways are removed. On the west side the Wells Fargo driveway shall be removed and access taken from Seneca Street or Nyberg Street. On the east side the driveway for 2S114B/2000 shall be removed and access taken from the Loop Road or Nyberg Street.

Nyberg Street to Tualatin-Sherwood Road:

There shall be no access to Martinazzi Avenue.

Response: As shown on the Master Plan Site Plan and identified in the TIA provided with this application, the Applicant is proposing to construct Street "A" that would provide right-in, right-out access onto Boones Ferry Road.

V. CONCLUSION

The Nyberg Rivers Master Plan represents a comprehensive and collaborative effort to create a vibrant center that provides a seamless extension of the Tualatin City Center. The primary commercial tenants will work to attract regional visitors to the City core in an effort to create a more vibrant and active City Center. The mix of uses will create a sense of place, with a vibrancy present during all hours and days of the week. In addition, this project will provide pedestrian and bicycle amenities and linkages to the regional framework to encourage a more active and healthy option for visitors to the site. The proposed public improvements, when combined with the on-site pedestrian and landscape amenities, provide a safe and efficient network for multi-modal access to and through the site. As evidenced throughout this project narrative, Nyberg Rivers does meet or exceed any applicable development regulation and objective of the Central Urban Renewal Plan, the Tualatin Municipal Code, the Community Plan, and the Tualatin Development Code. Based on this evidence provided, the applicant requests Master Plan and Conditional Use Approval so that the applicant may proceed with Architectural Review.

EXHIBIT A—
NYBERG RIVERS MASTER PLAN DOCUMENT

A BOUND COPY IS PROVIDED WITH THE APPLICATION AS A
STANDALONE EXHIBIT



City of Tualatin

www.ci.tualatin.or.us

CONDITIONAL USE PERMIT CERTIFICATION OF SIGN POSTING



The applicant shall provide and post a sign pursuant to Tualatin Development Code (TDC) 31.064(2). Additionally, the 18" x 24" sign must contain the application number, and the block around the word "NOTICE" must remain **lime green** composed of the **RGB color values Red 146, Green 208, and Blue 80**. Additionally, the potential applicant must provide a flier (or flyer) box on or near the sign and fill the box with brochures reiterating the meeting info and summarizing info about the potential project, including mention of anticipated land use application(s). Staff has a Microsoft PowerPoint 2007 template of this sign design available through the Planning Division homepage at < www.tualatinoregon.gov/planning/land-use-application-sign-templates>.

As the applicant for the _____ project, I hereby certify that on this day, _____ sign(s) was/were posted on the subject property in accordance with the requirements of the Tualatin Development Code and the Community Development Department - Planning Division.

Applicant's Name: _____
(PLEASE PRINT)

Applicant's Signature: _____

Date: _____

**APPLICATION FOR TUALATIN
CENTRAL URBAN RENEWAL DISTRICT MASTER PLAN**

Community Development Department
Planning Division (503-691-3026)
18880 SW Martinazzi Avenue
Tualatin, Oregon 97062-7092

Case No _____
Fee Rec'd _____
Receipt No _____
By _____

PLEASE PRINT IN INK OR TYPE

CURD Block 1-5

Planning District CC, CO, RH

Applicant's Name Centercal Properties, LLC

Applicant's Address 7455 SW Bridgeport Rd, Suite 205 Tigard, OR 97224
(street) (city) (state) (zip)

Applicant is: Owner__ Contract Purchaser__ Developer Agent__ Other__

Phone (503) 968-8940 Fax _____ Email _____

Property #1 Owner Name TUALA Northwest, LLC Phone (503) 799-8324

Property #1 Owner Address 5638 Dogwood Drive Lake Oswego, OR 97035

Address of property #1 7655 SW Nyberg Street Lot area 31.91 acres

Assessor's Map Number 31W11D Tax Lot Number(s) 1500, 1601, 1602, 1900, 2000, 2001, 2100, 2502, 2506, 2507, 2508, 2700

Existing Buildings (Number and Type) _____

Current use Shopping Center

Use page 2 of this application form to list additional properties.

As the person responsible for this application, I, the undersigned hereby acknowledge that I have read the above application and its attachments, understand the requirements described herein, and state that the information supplied is as complete and detailed as is currently possible, to the best of my knowledge.

Name Michael Cerbone Date 4/8/2013 Phone (503) 419-2500

Address 5415 SW Westgate Dr, Suite 100 Portland, OR 97221

Property #2 Owner Name Dean & Rana F McBale Phone _____

Property #2 Owner Address 17180 SE McLoughlin Blvd Milwaukie, OR 97267

Address of property #2 7455 & 7447 SW Nyberg St Lot area 2.43 acres

Assessor's Map Number _____ Tax Lot Number(s) 2502, 2508

Existing Buildings (Number and Type) Vacant

Current use _____

Property #3 Owner's Name _____ Phone _____

Property #3 Owner's Address _____

Address of property #3 _____ Lot area _____ acres

Assessor's Map Number _____ Tax Lot Number(s) _____

Existing Buildings (Number and Type) _____

Current use _____

Property #4 Owner's Name _____ Phone _____

Property #4 Owner's Address _____

Address of property #4 _____ Lot area _____ acres

Assessor's Map Number _____ Tax Lot Number(s) _____

Existing Buildings (Number and Type) _____

Current use _____



City of Tualatin

www.ci.tualatin.or.us

APPLICATION FOR CONDITIONAL USE

Community Development Department - Planning Division
18880 S.W. Martinazzi Avenue
Tualatin, OR 97062
503-691-3026

Case No. _____
Fee Rec'd. _____
Receipt No. _____
Date Rec'd. _____
By _____

PLEASE PRINT IN INK OR TYPE

Code Section 50.030, 53.055 Conditional Use to allow A sporting goods store in the CO planning district and permanent outdoor sales uses within the CC planning district Planning District CO

Owner's Name TUALA Northwest, LLC Attn: Arne Nyberg Phone (503) 799-8324

Owner's Address 5638 Dogwood Drive Lake Oswego OR 97035
(street) (city) (state) (ZIP)

Owner recognition of application:

MANAGER ARNE C. NYBERG
signature of owner(s)

Applicant's Name Centercal Properties, LLC Phone (503) 968-8940

Applicant's Address 7455 SW Bridgeport Rd, Suite 205 Tigard OR 97224
(street) (city) (state) (ZIP)

Applicant is: Owner Contract Purchaser Developer Agent
Other _____

Contact person's name Michael Cerbone, Planning Project Manager Phone (503) 419-2500

Contact person's address 5415 SW Westgate Dr, Suite 100 Portland OR 97221
(street) (city) (state) (ZIP)

Assessor's Map Number 31W11D Tax Lot Number(s) 2700

Address of Property 7500 SW Nyberg Street Lot Area 11 acres

Existing Buildings (Number and Type) _____

Current Use Vacant

As the person responsible for this application, I, the undersigned hereby acknowledge that I have read the above application and its attachments, understand the requirements described herein, and state that the information supplied is as complete and detailed as is currently possible, to the best of my knowledge.

Name Michael Cerbone Date _____ Phone (503) 419-2500
Address 5415 SW Westgate Dr, Suite 100 Portland OR 97221
(street) (city) (state) (ZIP)

NYBERG RIVERS TUALATIN, OREGON

APRIL 4, 2013



Perkowitz + Ruth
ARCHITECTS



1 - SOUTH ELEVATION
Scale 1/16"=1'-0"

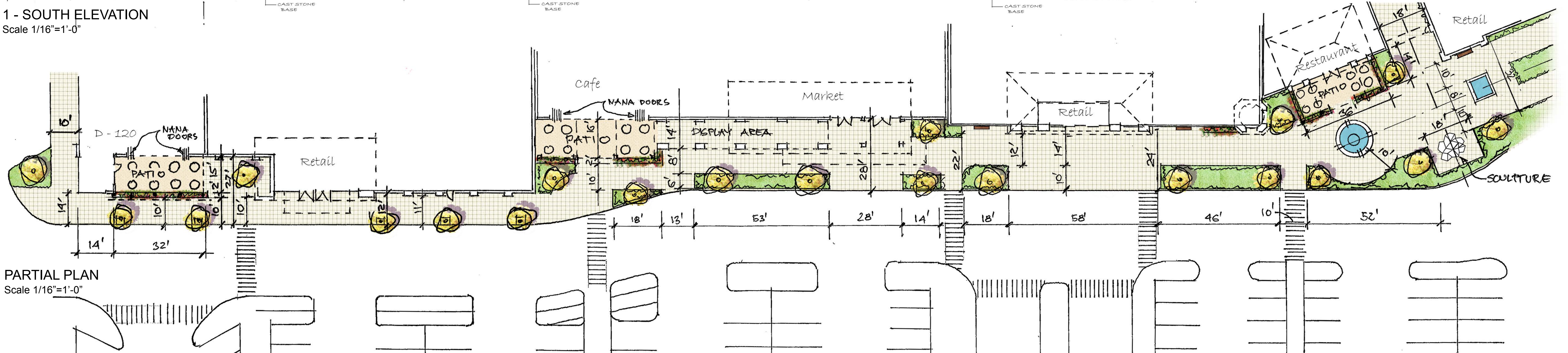

PARTIAL PLAN
Scale 1/16"=1'-0"

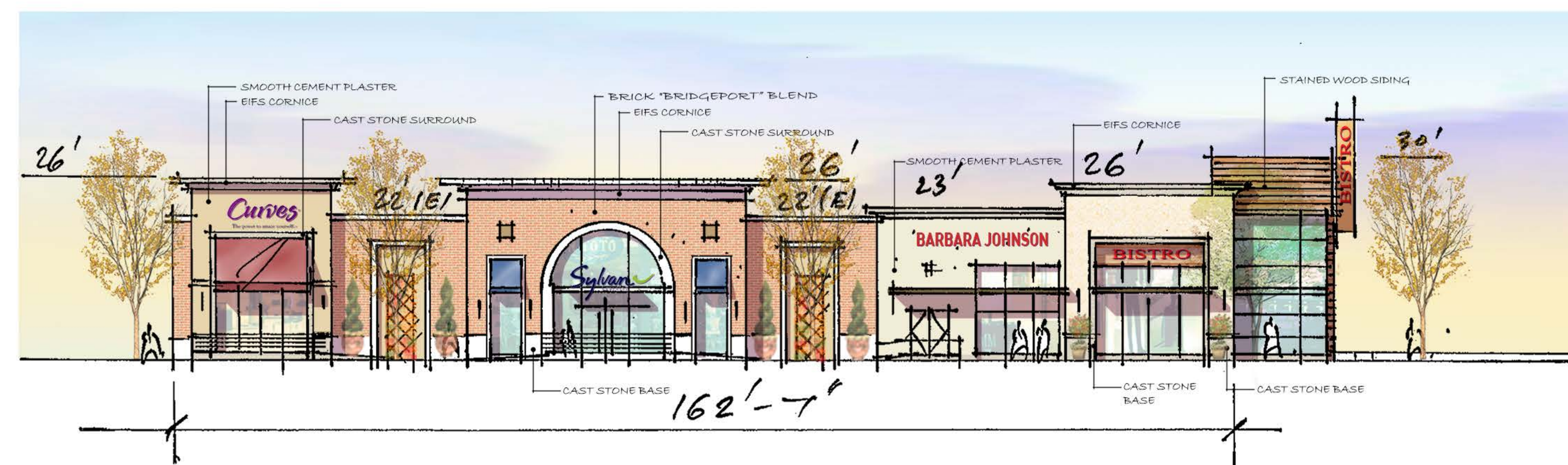

2 - WEST ELEVATION
Scale 1/16"=1'-0"

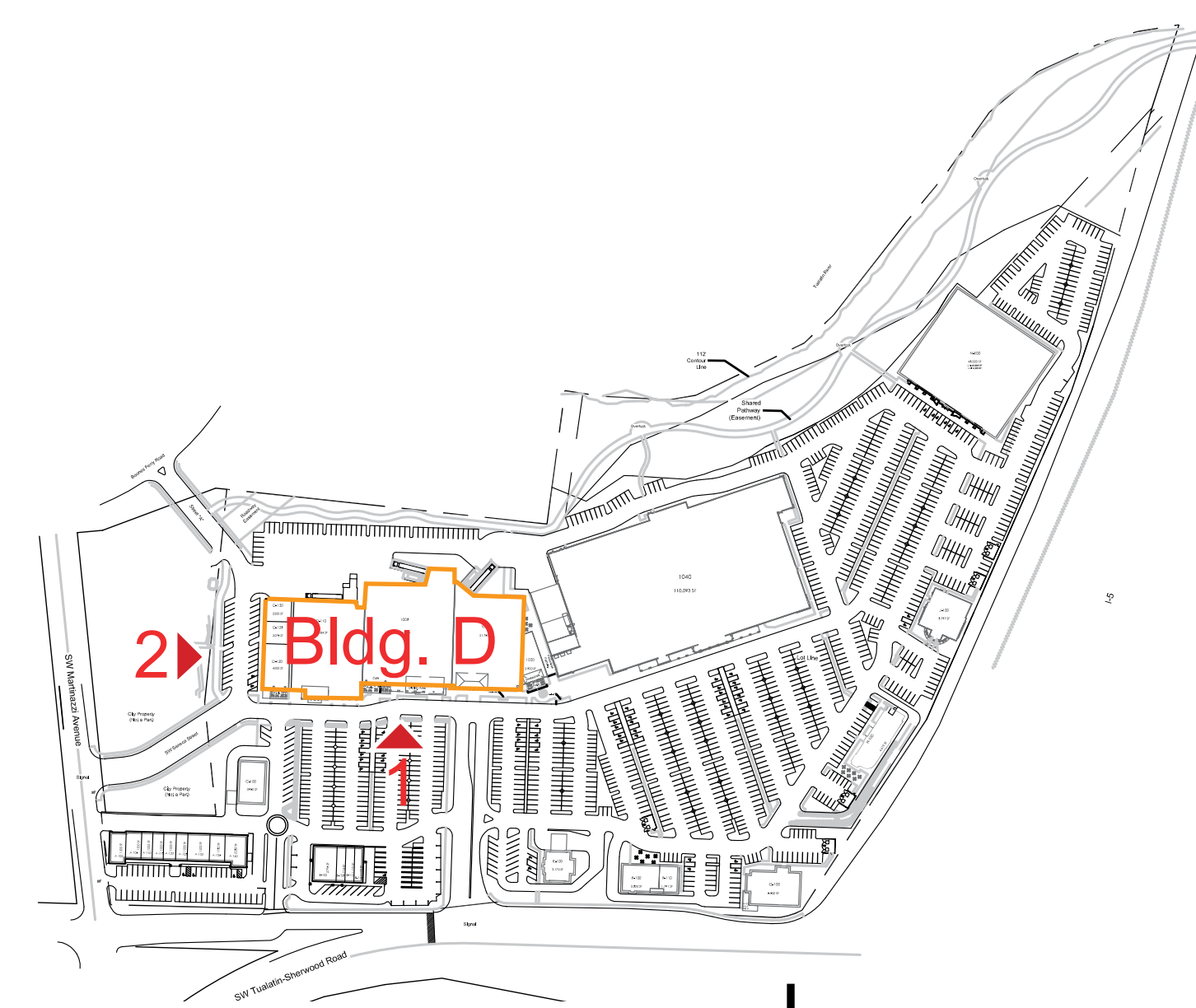

KEY PLAN

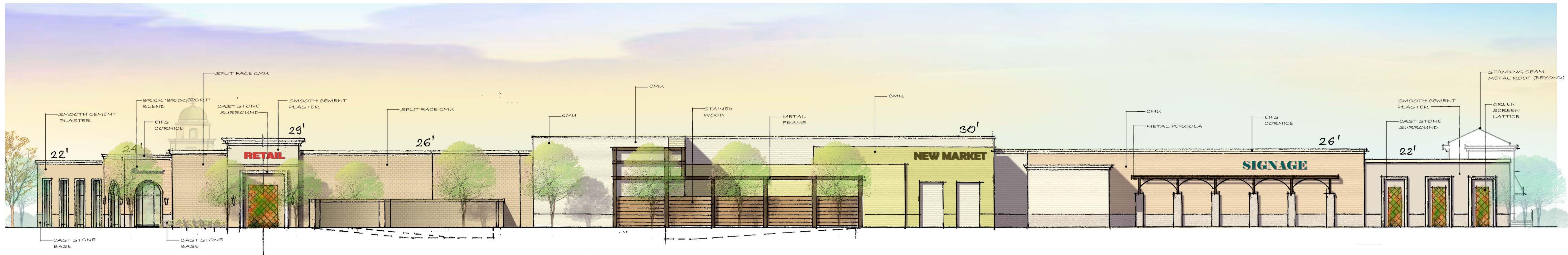

3 - NORTH ELEVATION
Scale 1/16"=1'-0"

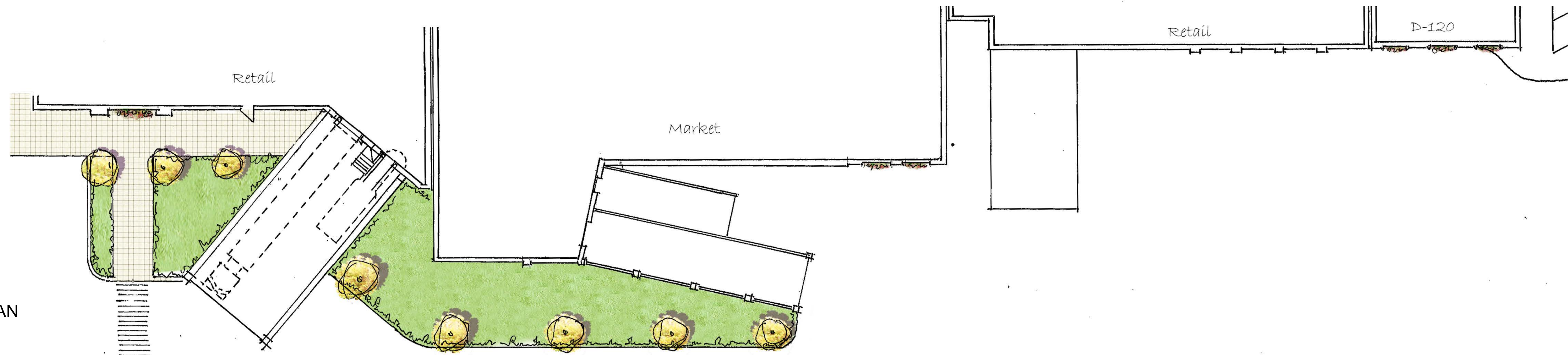

PARTIAL PLAN
Scale 1/16"=1'-0"

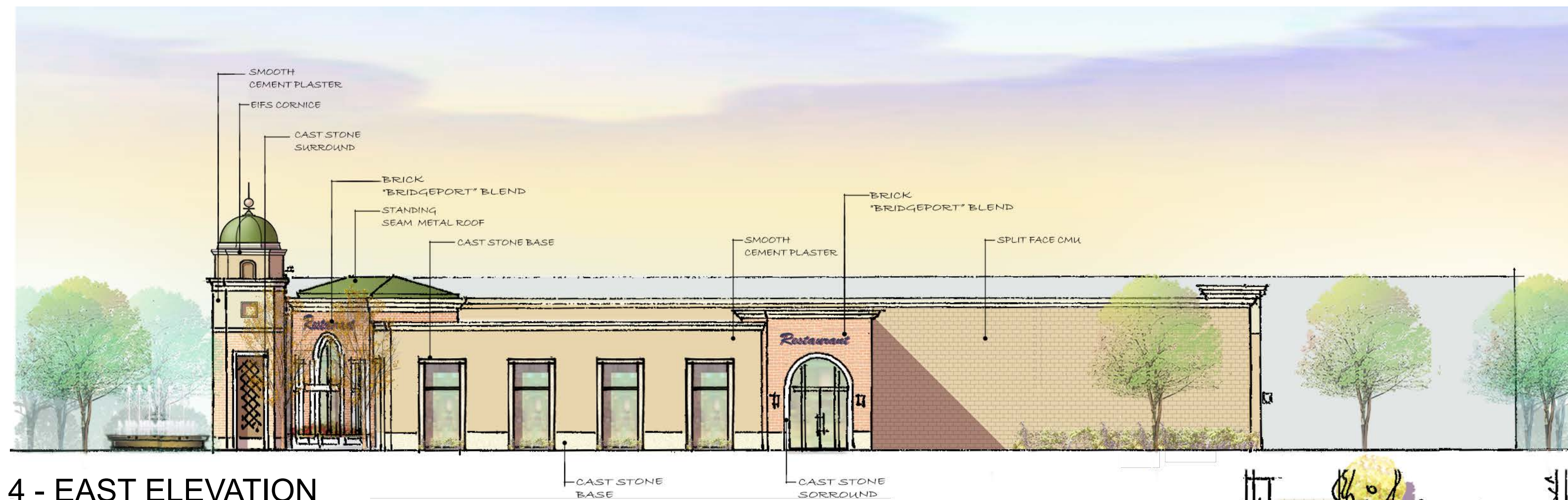

4 - EAST ELEVATION
Scale 1/16"=1'-0"

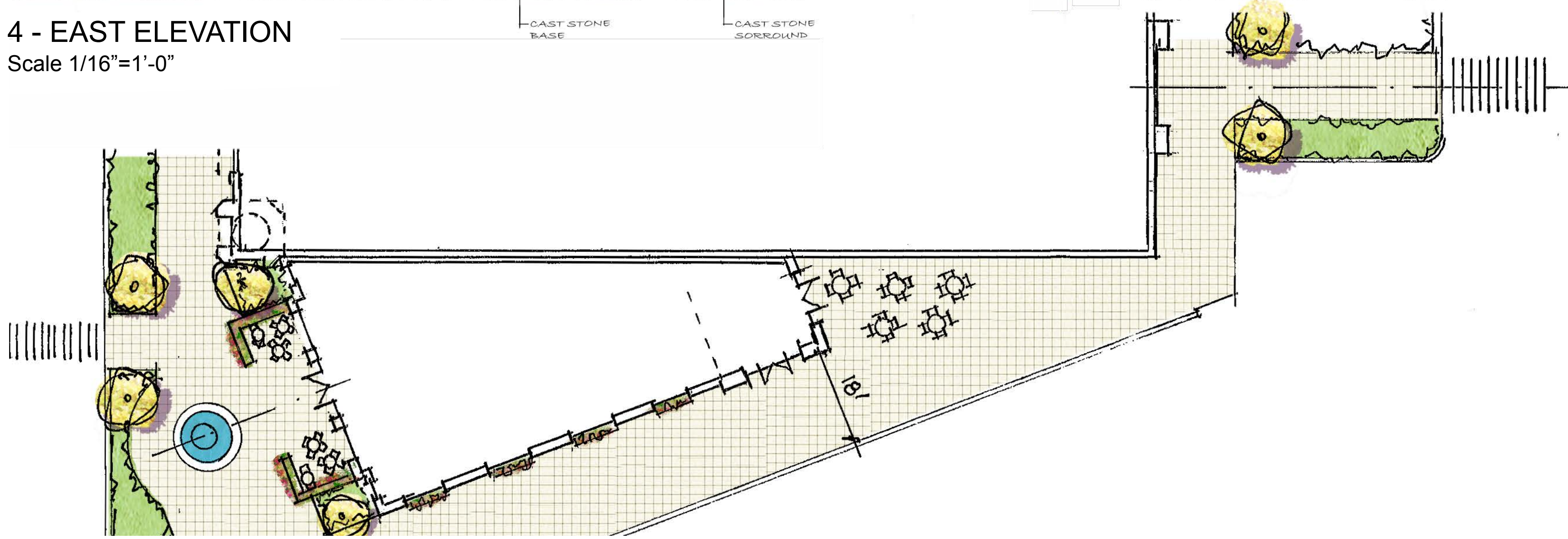

PARTIAL PLAN
Scale 1/16"=1'-0"

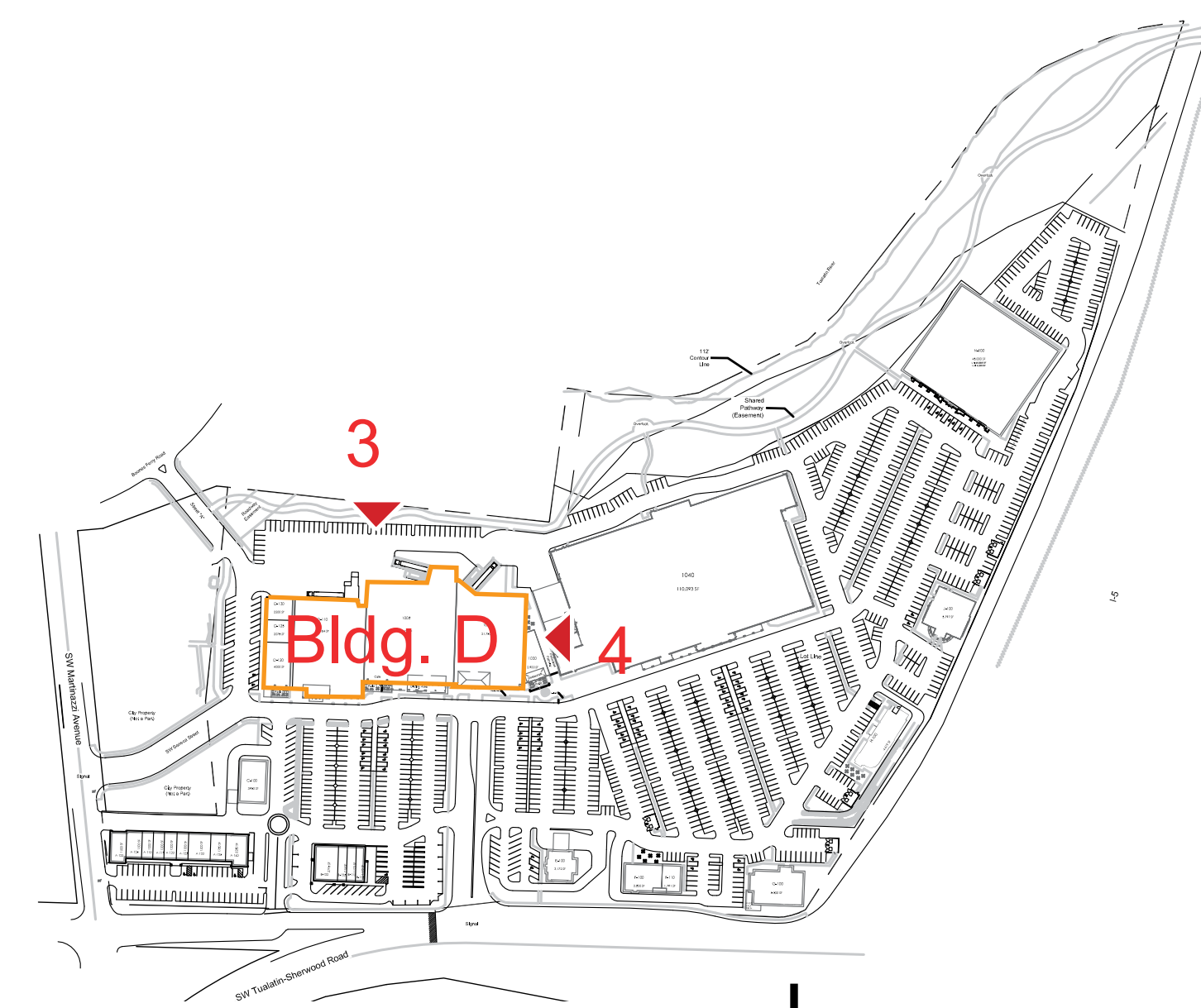

KEY PLAN



1N - SOUTH ELEVATION
Scale 1/16"=1'-0"



2N - WEST ELEVATION
Scale 1/16"=1'-0"

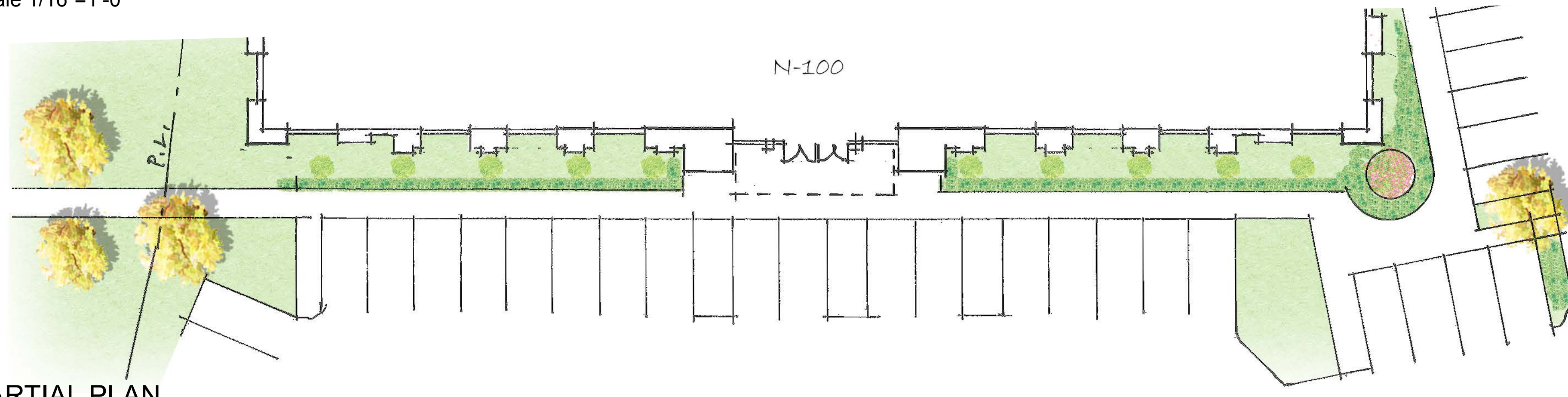

PARTIAL PLAN
Scale 1/16"=1'-0"

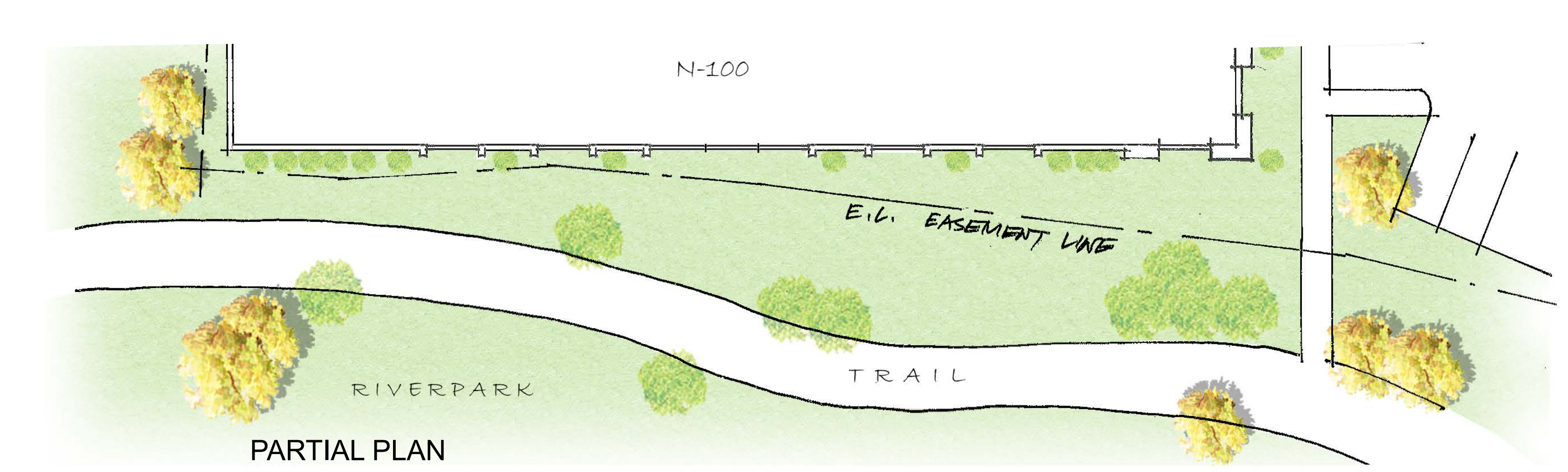

PARTIAL PLAN
Scale 1/16"=1'-0"

Building N Elevations



1F - NORTH ELEVATION
Scale 1/16"=1'-0"



2F - WEST ELEVATION
Scale 1/16"=1'-0"

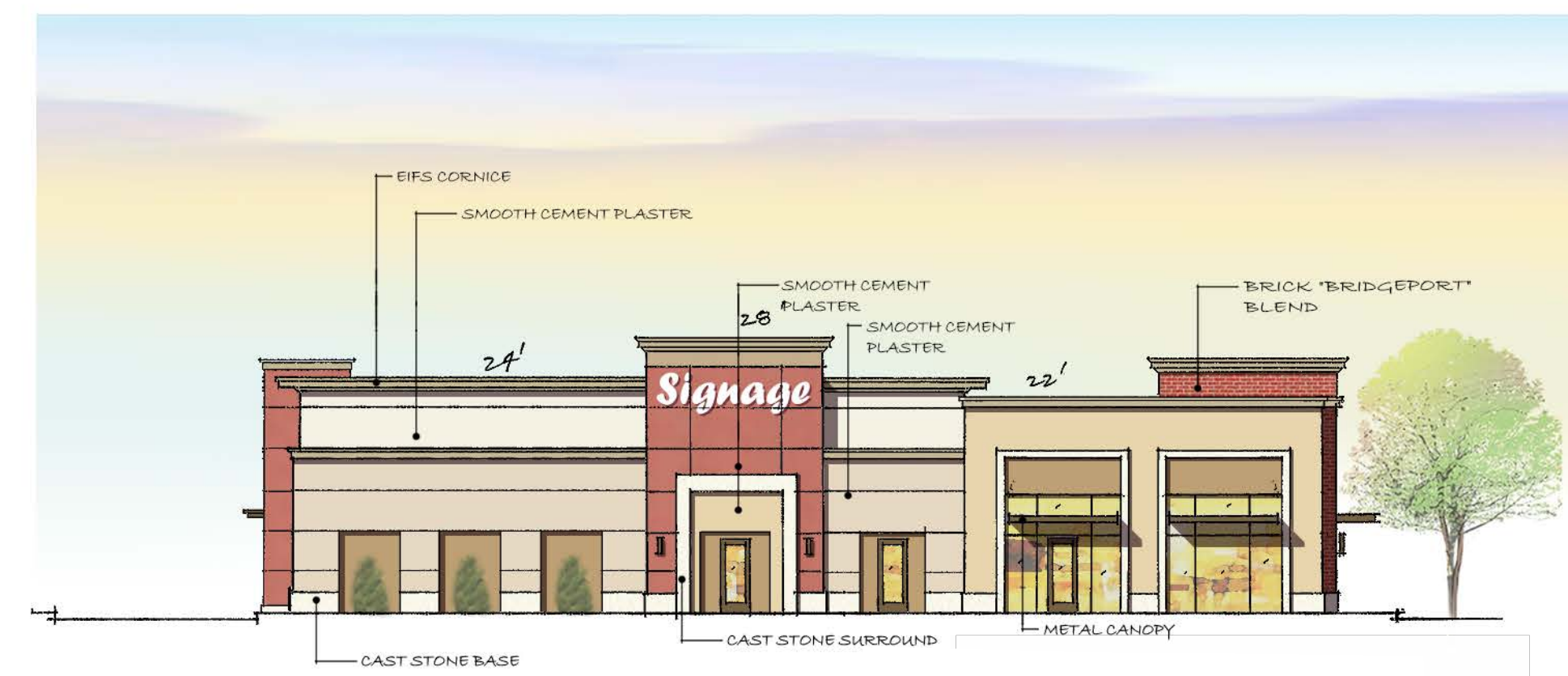

3F - SOUTH ELEVATION
Scale 1/16"=1'-0"



4F - EAST ELEVATION
Scale 1/16"=1'-0"

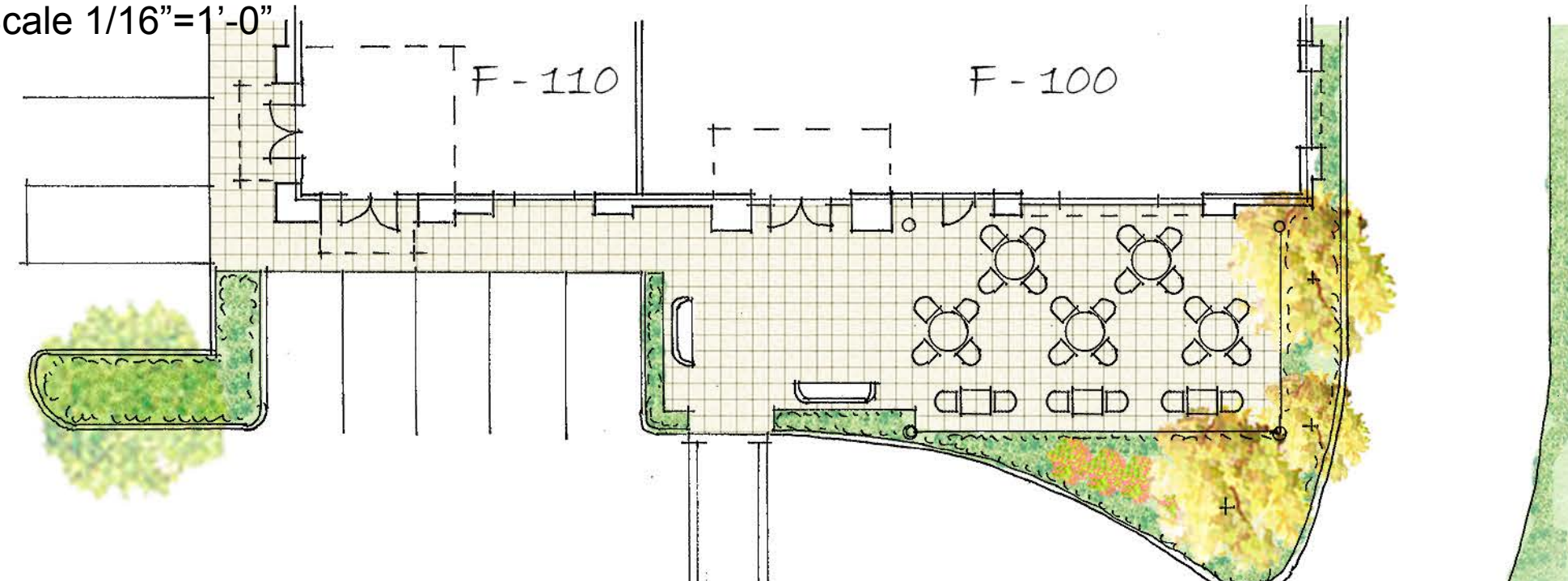

PARTIAL PLAN
Scale 1/16"=1'-0"

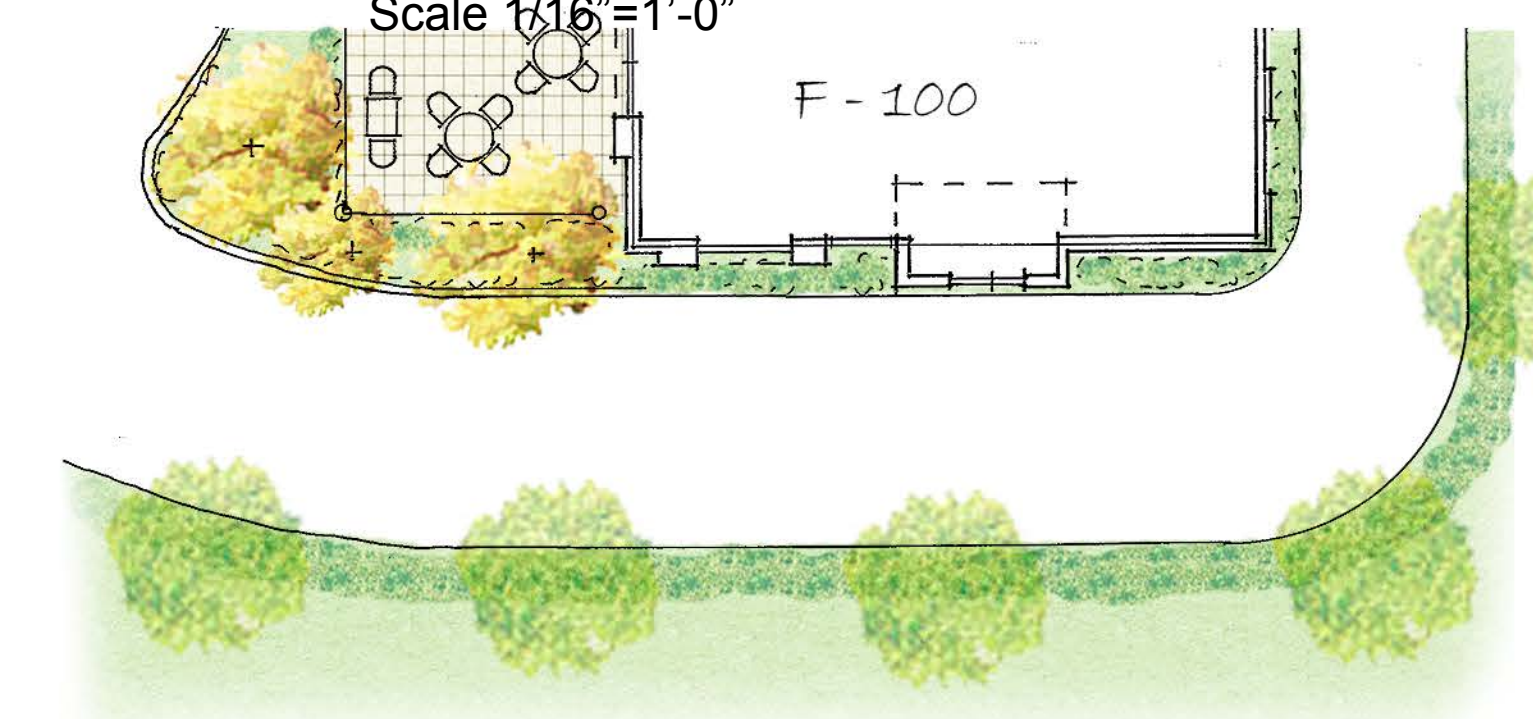

PARTIAL PLAN
Scale 1/16"=1'-0"

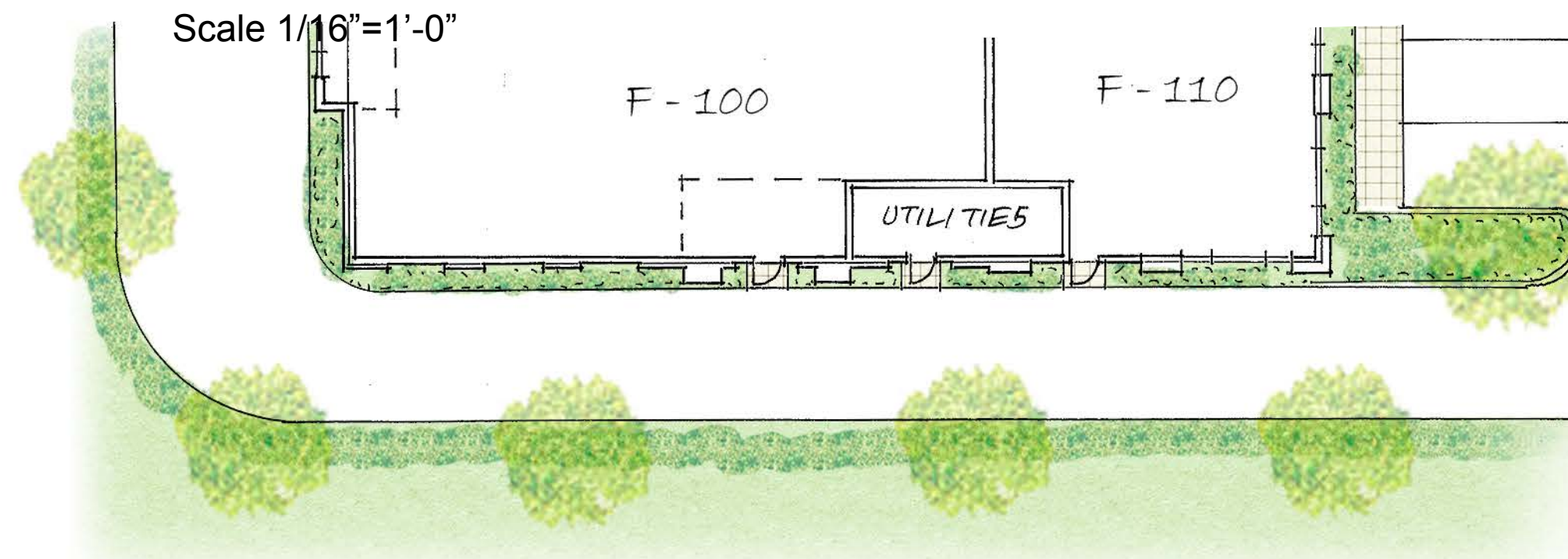

PARTIAL PLAN
Scale 1/16"=1'-0"

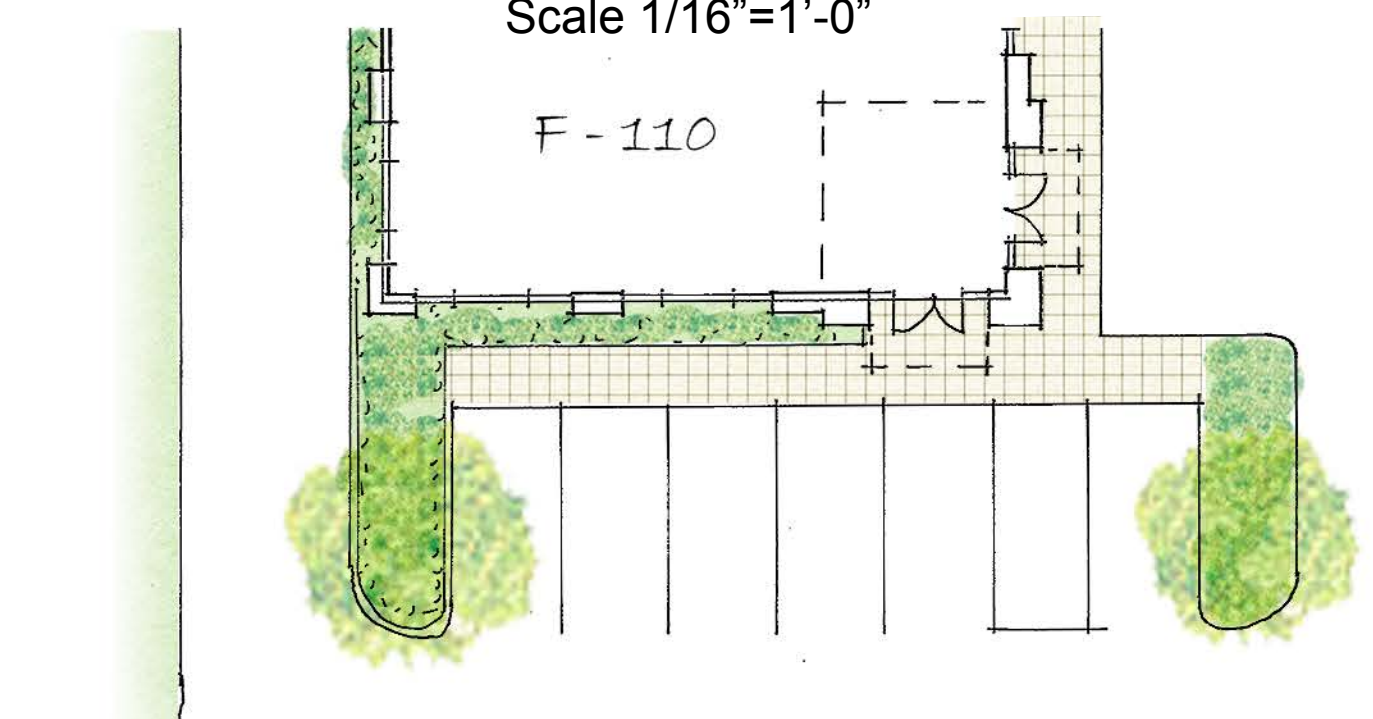

PARTIAL PLAN
Scale 1/16"=1'-0"

Building F Elevations

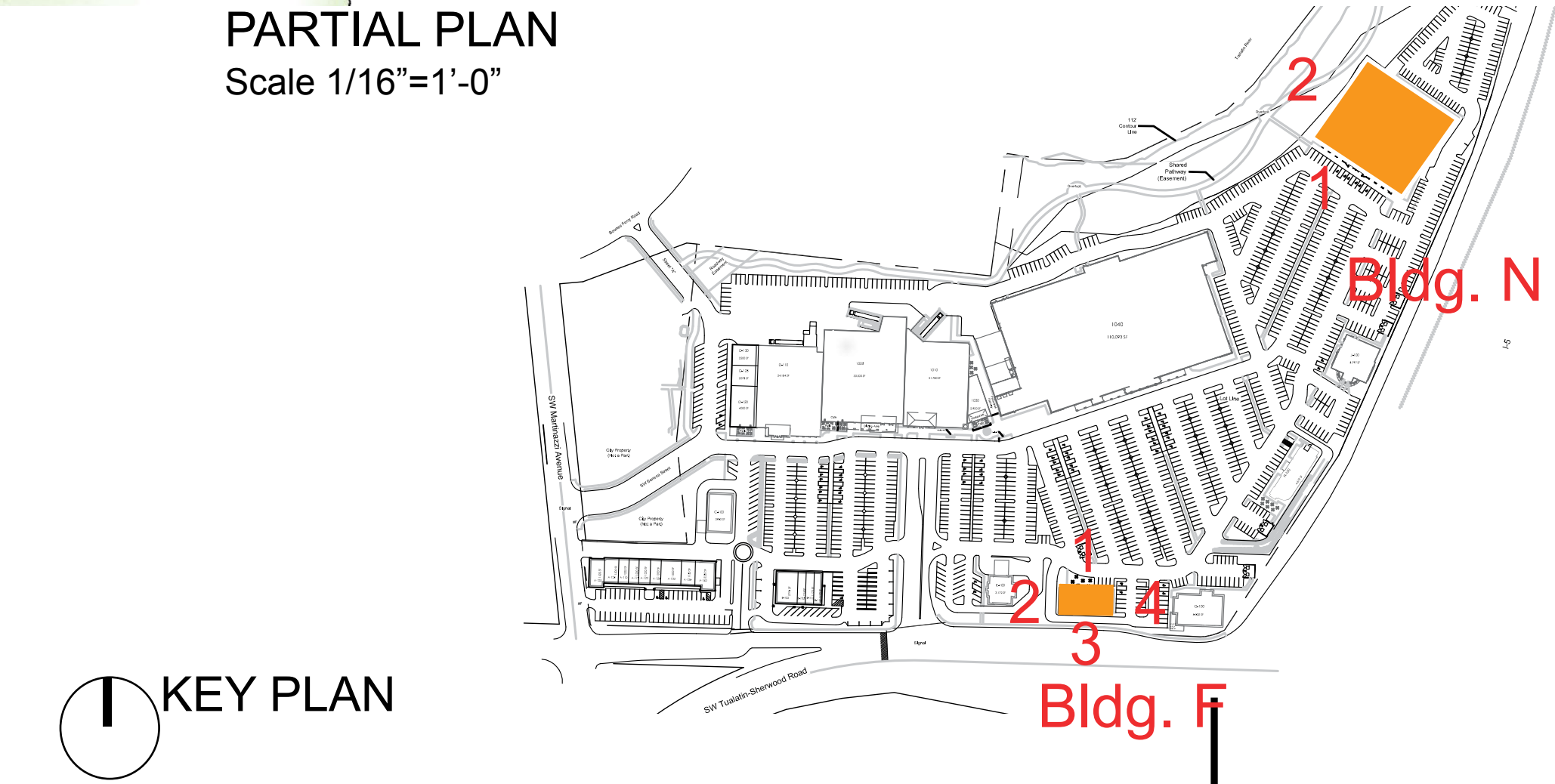

KEY PLAN

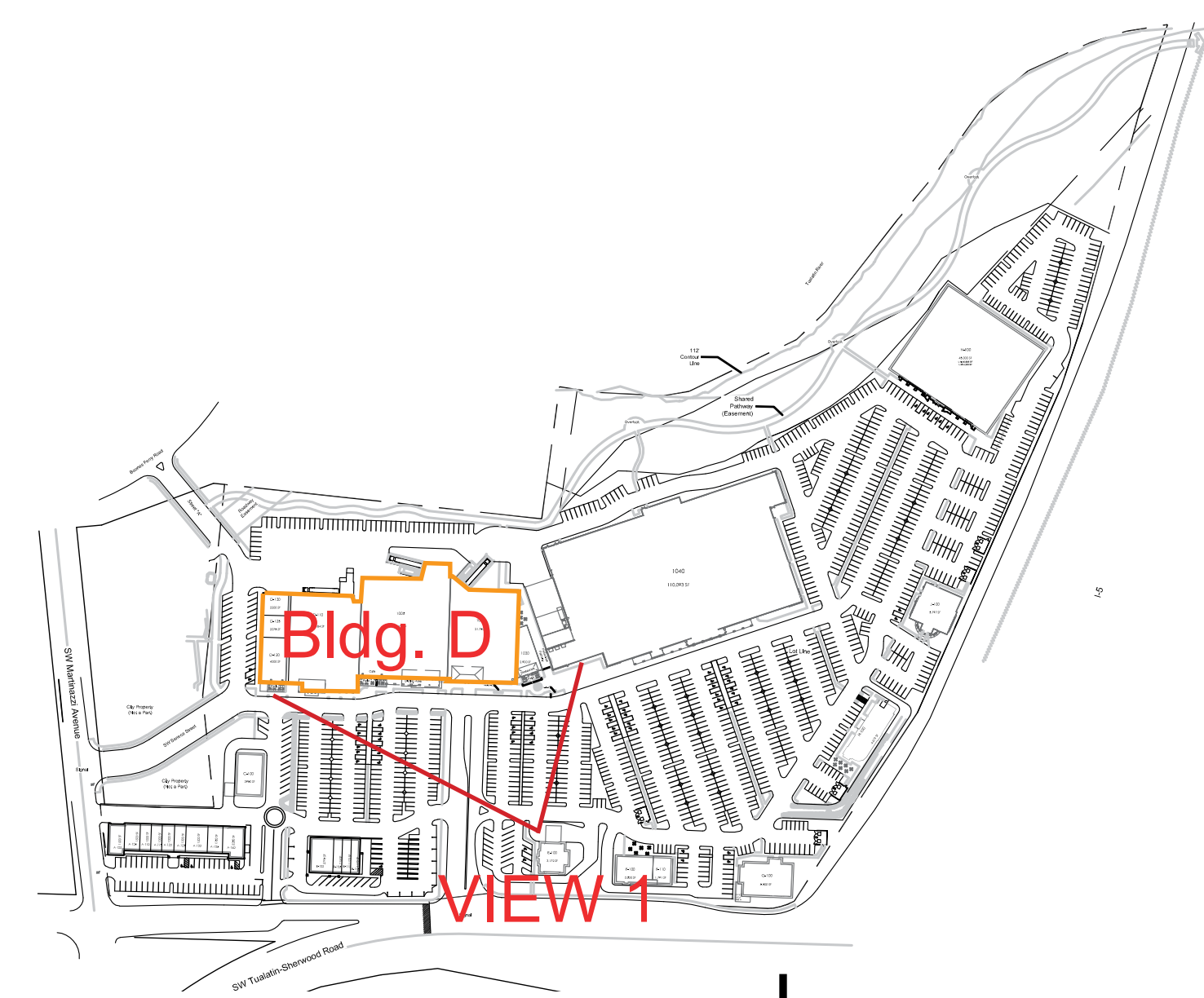

1 KEY PLAN

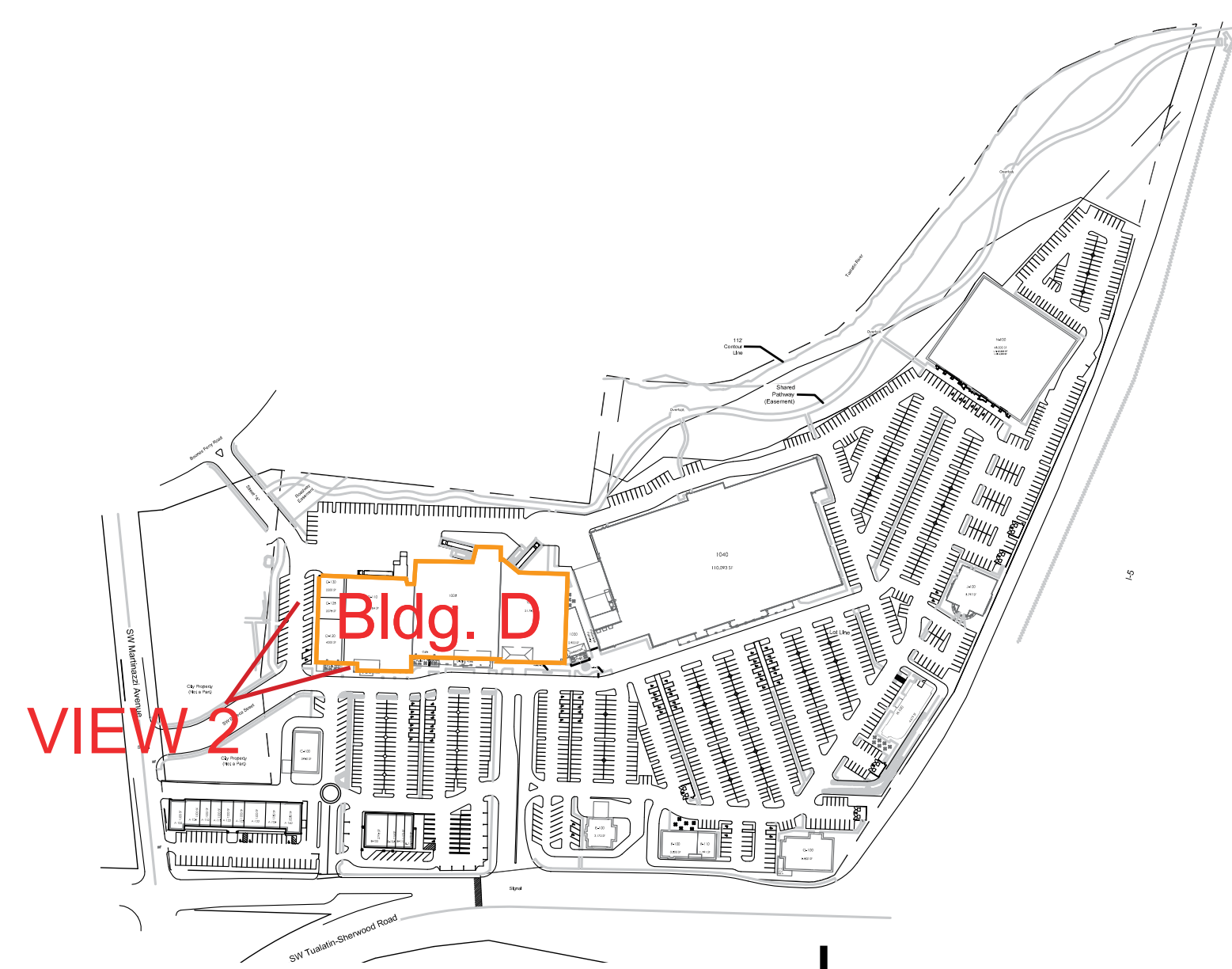

KEY PLAN

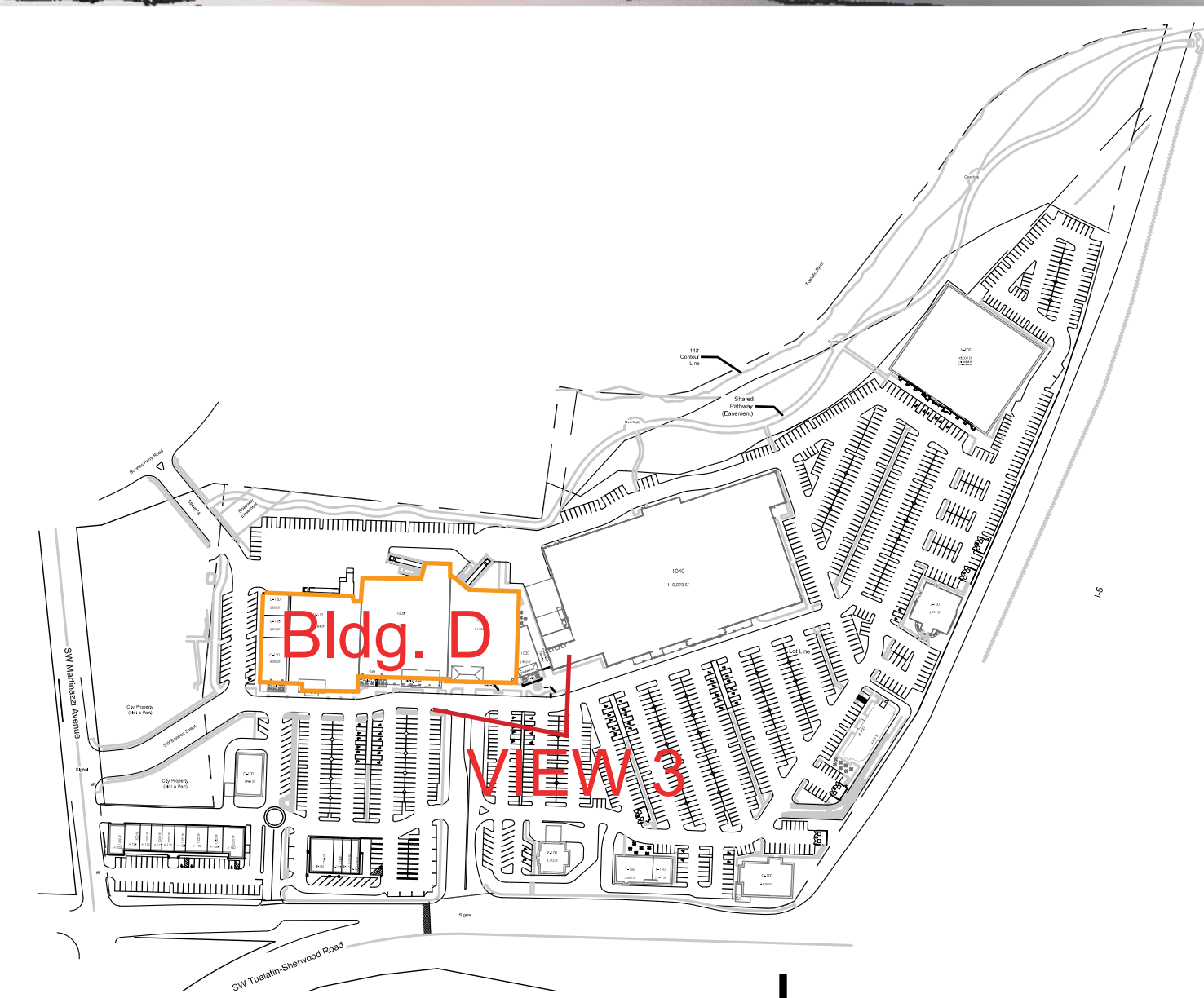

1 KEY PLAN

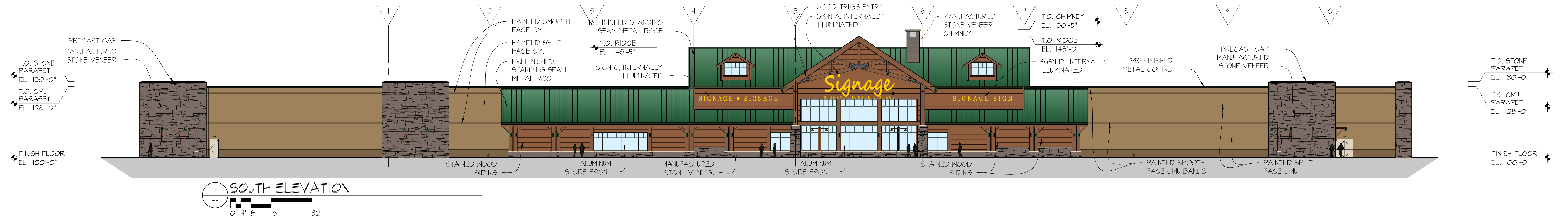

1 SOUTH ELEVATION

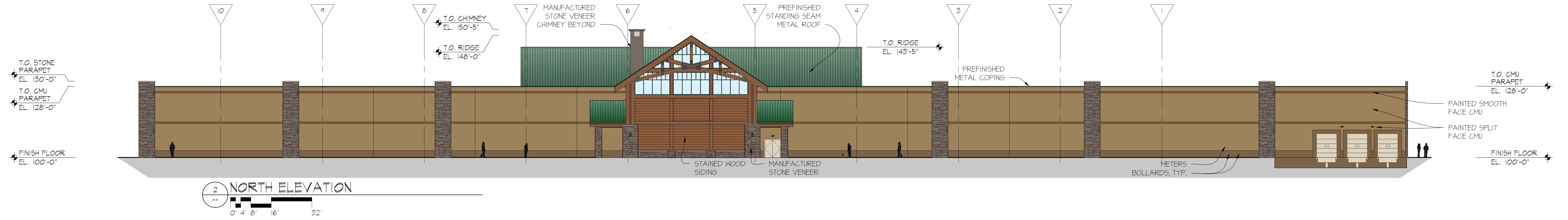

2 NORTH ELEVATION

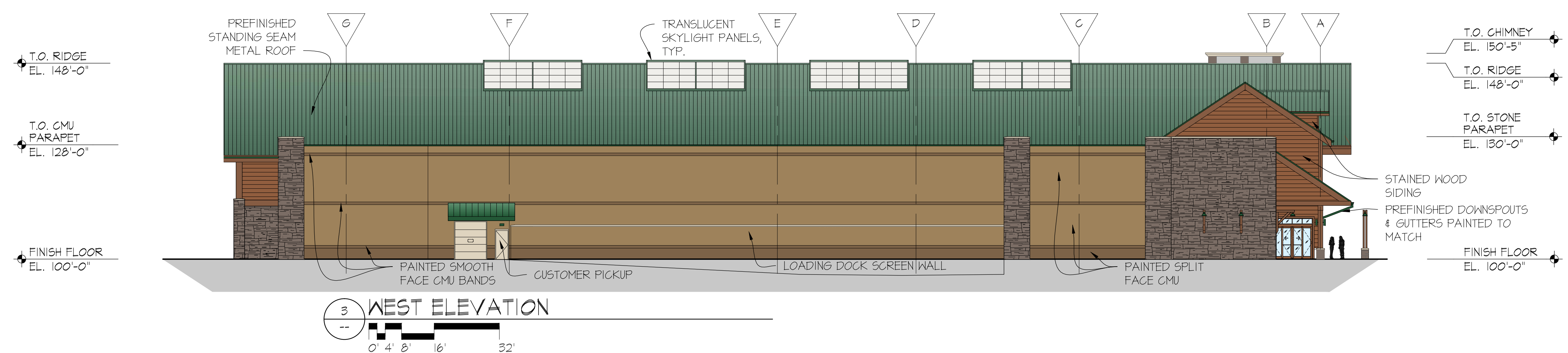

3 WEST ELEVATION

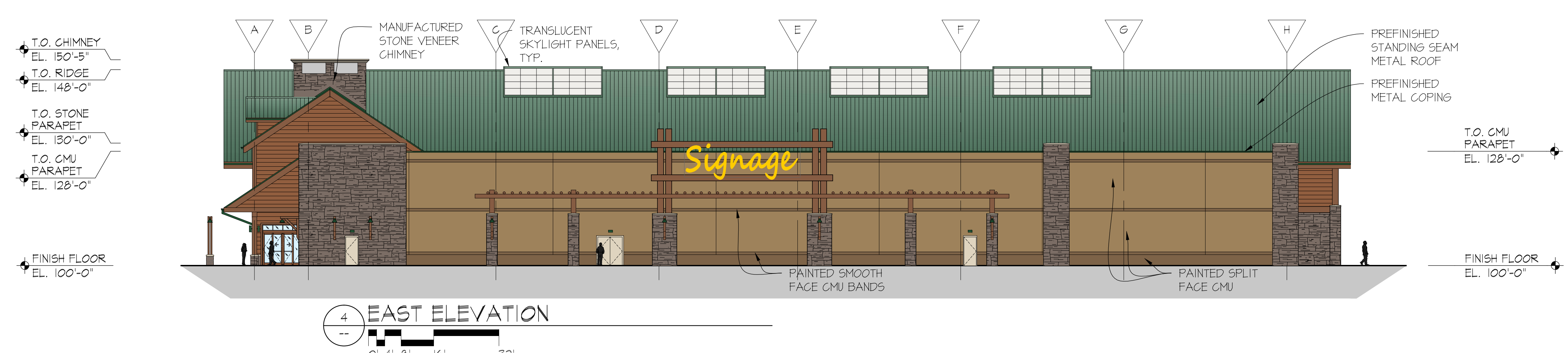

4 EAST ELEVATION

preliminary
not for construction
design submitted
28 march 2015

RETAIL CONCEPT | **PRELIMINARY DRAWINGS**
TUALATIN, OR

HBA
HOLLAND BASHAM ARCHITECTS

03/28/13
P# 12511.1



SOUTHWEST ELEVATION



NORTHWEST ELEVATION



NORTHEAST ELEVATION

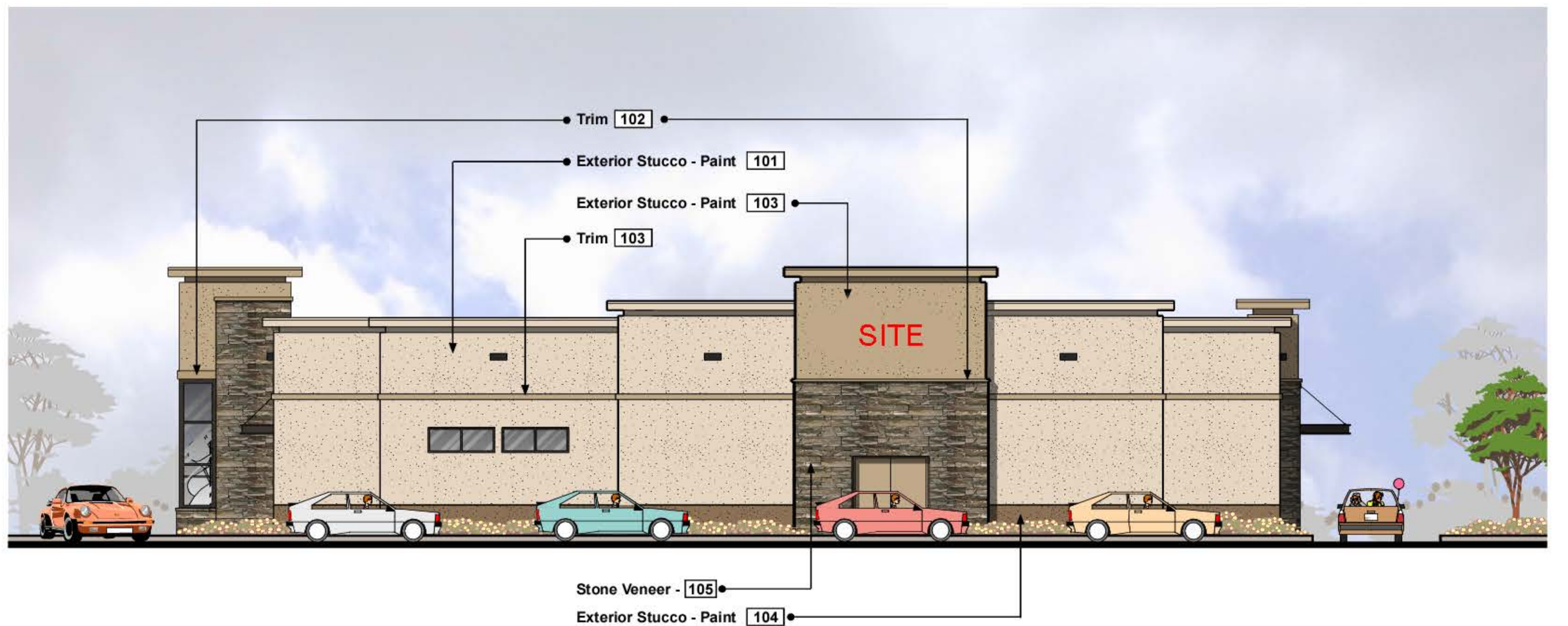

SOUTHEAST ELEVATION

**BUILDING H
PRELIMINARY ELEVATIONS
Tualatin, OR**

4-5-13

File Name: 12175E-ALL-4-5-13



Note:

All roof top mechanical equipment shall be located in equipment well and screened from view by parapet walls.

COLOR AND MATERIAL LEGEND

- 101 Paint - Sherwin Williams - #SW6155 "Rice Grain"
- 102 Valori Precast - "Cappuccino"
- 103 Paint - Sherwin Williams - #SW7549 "Studio Taupe"
- 104 Paint - Sherwin Williams - #SW6102 "Portabello"
- 105 Stone Veneer - Coronado Stone Pro-ledge "Crossroads"
- 106 Aluminum Awning - Color "Dark Bronze"

C · R · H · O

Architecture Interiors Planning

195 South "C" Street Suite 200

Tustin, California 92780

714 832 1834

FAX 714 832 1910

STRUCTURE TABLE:

- | | | | | | | | | | | | | | | | | | | | | | | | | | | | | | | | | | | | | | | | | | | | | | | | | | |
|---|--|--|---|---|--|---|--|--|--|---|-------------------------|---|---|--|---|---|---|---|---|---|---|--|--|--|--|---|---|--|--|---|---|---|--|---|--|--|---|--|--|--|--|-------------------------|--|---|--|--|--|--|---|
| 1 SANITARY SEWER MANHOLE
RIM = 132.74'
6" PVC(SW) = 126.14'
8" PVC(S) = 125.83' (NO FLOW)
8" PVC(N) = 125.40' | 2 SANITARY SEWER MANHOLE
RIM = 131.92'
8" PVC(N) = 124.05'
8" PVC(S) = 123.82'
8" PVC(W) = 123.66' | 3 SANITARY SEWER MANHOLE
RIM = 126.15'
8" PVC(N) = 122.90'
8" PVC(E) = 122.91'
8" PVC(S) = 122.81' | 4 SANITARY SEWER MANHOLE
RIM = 127.16'
8" PVC(N) = 122.71'
8" PVC(W) = 122.63' | 5 SANITARY SEWER MANHOLE
RIM = 126.69'
8" PVC(E) = 121.44'
8" PVC(W) = 121.38' | 6 SANITARY SEWER MANHOLE
RIM = 125.10'
8" PVC(E) = 119.54'
8" PVC(SW) = 119.49' | 7 SANITARY SEWER MANHOLE
RIM = 125.94'
8" PVC(N) = 118.90'
8" PVC(S) = 118.84' | 8 SANITARY SEWER MANHOLE
RIM = 126.89'
8" STEEL(N) = 122.76'
8" PVC(N) = 117.96'
8" PVC(SE) = 119.26'
8" PVC(W) = 117.89' | 9 SANITARY SEWER MANHOLE
RIM = 123.37'
8" PVC(N) = 116.59'
8" PVC(E) = 116.57'
8" PVC(S) = 116.67' | 10 SANITARY SEWER MANHOLE
RIM = 128.45'
6" PVC(N) = 119.88'
6" PVC(S) = 119.82' | 11 SANITARY SEWER MANHOLE
RIM = 124.21'
6" PVC(N) = 115.21'
8" PVC(E) = 114.97'
8" PVC(W) = 114.86'
FLOWLINE = 114.89' | 12 IE 10" CMP = 127.79' | 13 CATCH BASIN
RIM = 130.52'
6" CONC(S) = 128.87' | 14 CATCH BASIN
RIM = 126.29'
18" CONC(S) = 116.93'
18" CONC(N) = 116.85' | 15 STORM DRAINAGE MANHOLE
RIM = 126.29'
18" CONC(S) = 116.93'
18" CONC(N) = 116.85' | 16 CATCH BASIN
RIM = 121.82'
OUT WEST | 17 CATCH BASIN
RIM = 124.00'
OUT EAST | 18 STORM DRAINAGE MANHOLE
RIM = 127.23'
18" CONC(S) = 117.28'
12" CONC(W) = 117.24'
18" CONC(N) = 117.19' | 19 STORM DRAINAGE MANHOLE
RIM = 127.06'
18" CONC(E) = 117.63'
18" CONC(W) = 117.62'
18" CONC(N) = 117.34' | 20 STORM DRAINAGE MANHOLE
RIM = 127.88'
18" CONC(E) = 117.52'
15" CONC(S) = 117.51'
18" CONC(W) = 117.45' | 21 CATCH BASIN
RIM = 124.81'
OUT WEST | 22 CATCH BASIN
RIM = 124.56'
OUT WEST | 23 STORM DRAINAGE MANHOLE
RIM = 124.32'
12" PVC(N) = 118.55'
18" CONC(E) = 118.11' W/ PLUG
12" PVC(S) = 119.32'
18" CONC(W) = 118.11' W/ PLUG | 24 CATCH BASIN
RIM = 123.69'
OUT NORTH | 25 CATCH BASIN
RIM = 123.66'
8" IRON PIPE(E/W) = 121.91'
SUMP = 121.91' | 26 CATCH BASIN
RIM = 123.74'
OUT SOUTHWEST | 27 CATCH BASIN
RIM = 124.23'
12" CMP(W) = 123.02'
SUMP = 122.93' | 28 CATCH BASIN
RIM = 122.43'
OUT EAST | 29 STORM DRAINAGE MANHOLE
RIM = 123.25'
12" CONC(N) = 119.64'
18" CONC(E) = 118.36'
12" CMP(SE) = 118.85'
8" CMP(W) = 119.44' | 30 CATCH BASIN
RIM = 122.85'
12" CMP(NW) = 120.93'
SUMP = 120.60' | 31 CATCH BASIN
RIM = 122.85'
OUT WEST | 32 CATCH BASIN
RIM = 123.75'
OUT WEST | 33 CATCH BASIN
RIM = 122.73'
12" CMP(NW) = 120.48'
8" CMP(W) = 120.48'
SUMP = 120.33' | 34 CATCH BASIN
RIM = 123.27'
12" CONC(SW) = 121.77'
8" IRON PIPE(E) = 121.72'
SUMP = 121.67' | 35 CATCH BASIN
RIM = 123.65'
OUT EAST | 36 CATCH BASIN
RIM = 123.58'
8" IRON PIPE(E) = 122.18'
SUMP = 122.18' | 37 CATCH BASIN
RIM = 123.66'
8" IRON PIPE(E/W) = 121.91'
SUMP = 121.91' | 38 CATCH BASIN
RIM = 123.63'
12" CPP(S) = 121.63'
SUMP = 121.63' | 39 CATCH BASIN
RIM = 124.23'
12" CONC(W) = 123.02'
SUMP = 122.93' | 40 CATCH BASIN
RIM = 126.79'
12" CONC(E) = 124.19'
SUMP = 123.04' | 41 CATCH BASIN
RIM = 127.59'
12" CONC(N) = 124.48'
12" CONC(W) = 123.94'
12" CONC(S) = 123.80' | 42 CATCH BASIN
RIM = 127.59'
12" CONC(N) = 124.48'
12" CONC(W) = 123.94'
12" CONC(S) = 123.80' | 43 IE 12" CMP = 124.08' | 44 CATCH BASIN
RIM = 127.79'
OUT SOUTHWEST | 45 CATCH BASIN
RIM = 127.67'
OUT EAST | 46 CATCH BASIN
RIM = 123.69'
OUT SOUTH | 47 CATCH BASIN
RIM = 125.54'
OUT NORTH | 48 CATCH BASIN
RIM = 124.70'
OUT NORTH | 49 CATCH BASIN
RIM = 124.51'
OUT NORTH | 50 CATCH BASIN
RIM = 123.67'
OUT WEST |
|---|--|--|---|---|--|---|--|--|--|---|-------------------------|---|---|--|---|---|---|---|---|---|---|--|--|--|--|---|---|--|--|---|---|---|--|---|--|--|---|--|--|--|--|-------------------------|--|---|--|--|--|--|---|

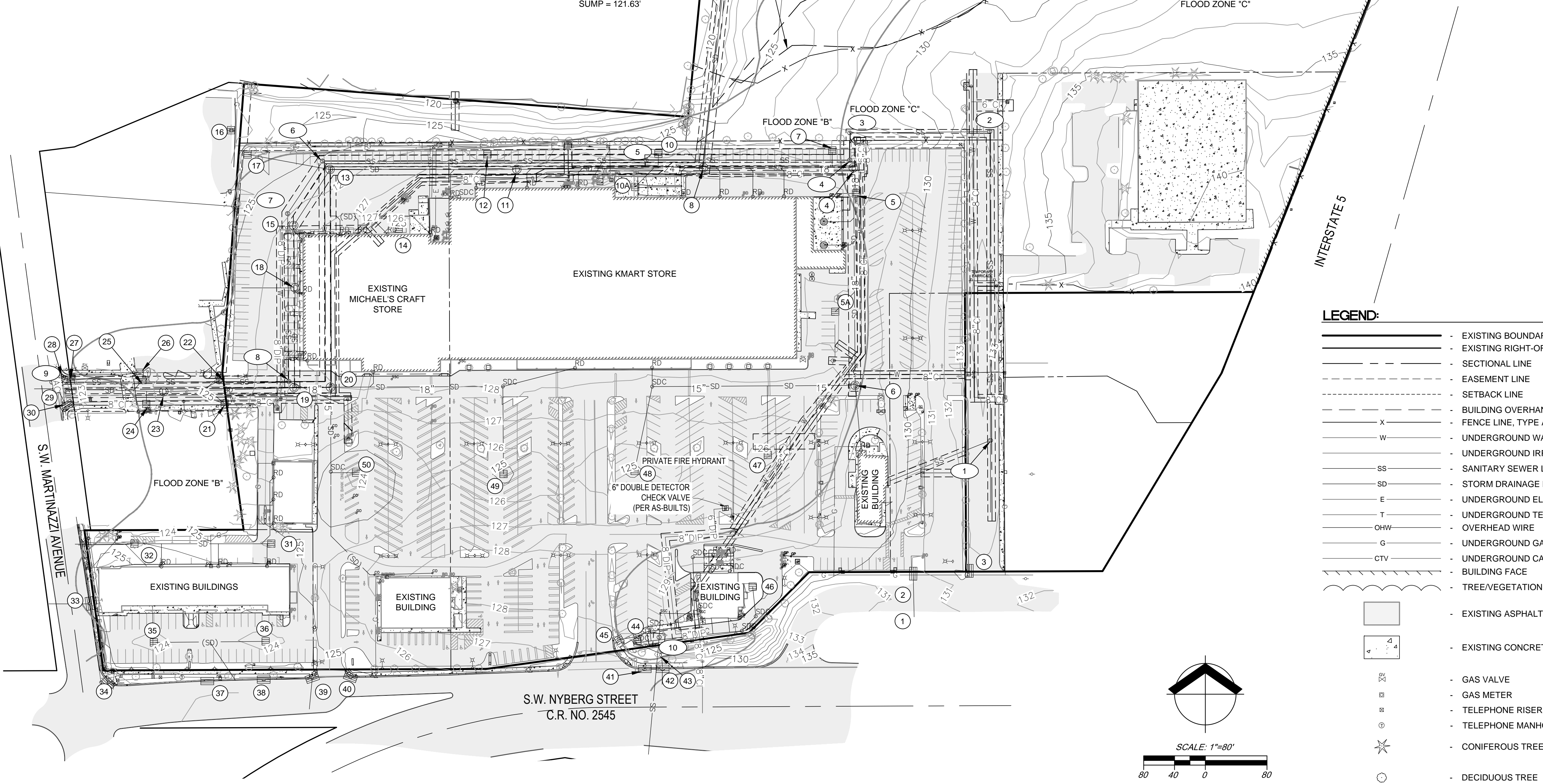

DATUM:
WASHINGTON COUNTY BENCHMARK NO. 822
A 3" BRASS DISK SET IN CONCRETE CURB AT THE SOUTHEAST
CORNER OF THE INTERSECTION OF SW BOONES FERRY ROAD
AND SW TUALATIN ROAD.
ELEVATION = 122.154'

BASIS OF BEARINGS:
ESTABLISHED BY HOLDING MONUMENTS [104] AND [100],
N 89°46'15" E ALONG THE NORTHERLY LINE OF (TITLE
REPORT) PARCEL III AND PARCEL V PER SURVEY NO.
21,181.

- LEGEND:**
- | | | | |
|-------|-----------------------------|---|----------------------------|
| — | EXISTING BOUNDARY LINE | ⊙ | SANITARY SEWER CLEANOUT |
| — | EXISTING RIGHT-OF-WAY LINE | ⊙ | SANITARY SEWER MANHOLE |
| - - - | SECTIONAL LINE | ⊙ | CATCH BASIN |
| - - - | EASEMENT LINE | ⊙ | STORM DRAIN MANHOLE |
| - - - | SETBACK LINE | ⊙ | ROOF DRAIN |
| - - - | BUILDING OVERHANG LINE | ⊙ | FIRE HYDRANT |
| - - - | FENCE LINE, TYPE AS NOTED | ⊙ | FIRE DEPARTMENT CONNECTION |
| - - - | UNDERGROUND WATER LINE | ⊙ | POST INDICATOR VALVE |
| - - - | UNDERGROUND IRRIGATION LINE | ⊙ | UNDERGROUND WATER VAULT |
| - - - | UNDERGROUND ELECTRICAL LINE | ⊙ | WATER VALVE |
| - - - | OVERHEAD WIRE | ⊙ | WATER METER BOX |
| - - - | UNDERGROUND GAS LINE | ⊙ | SPRINKLER VALVE |
| - - - | UNDERGROUND CABLE TV LINE | ⊙ | GROUND LIGHT |
| - - - | BUILDING FACE | ⊙ | STREET LIGHT (COBRA ARM) |
| - - - | TREE/VEGETATION LINE | ⊙ | SHOEBOX LIGHT (SINGLE) |
| - - - | EXISTING ASPHALT SURFACE | ⊙ | ACORN/GLOBE LIGHT |
| - - - | EXISTING CONCRETE SURFACE | ⊙ | ELECTRIC METER |
| ⊙ | GAS VALVE | ⊙ | TRANSFORMER |
| ⊙ | GAS METER | ⊙ | PARKING BUMPER |
| ⊙ | TELEPHONE RISER | ⊙ | TRAFFIC SIGNAL POLE |
| ⊙ | TELEPHONE MANHOLE | ⊙ | SIGNAL JUNCTION BOX |
| ⊙ | CONIFEROUS TREE | ⊙ | UNKNOWN CLEANOUT |
| ⊙ | DECIDUOUS TREE | ⊙ | UNKNOWN MANHOLE |
| | | ⊙ | BOLLARD |
| | | ⊙ | GATE POST |
| | | ⊙ | MAILBOX |
| | | ⊙ | SIGN |

EXISTING CONDITIONS
NYBERG RIVERS MASTER PLAN
TUALATIN, OREGON

PROJECT NO.: 21198310
DATE: 04/08/13
DESIGNED BY: MJZ
DRAWN BY: MJZ
CHECKED BY: JRS

EXISTING CONDITIONS
C0.0

Cardno
Shaping the Future
PORTLAND
5415 SW WESTGATE DR. STE 100, PORTLAND, OR 97221
TEL: (503) 419-2500 FAX: (503) 419-2800
www.cardno.com

CENTERCAL
Perkowitz + Ruth
ARCHITECTS



- LEGEND**
- PROPOSED BUILDING LINE
 - EXISTING BOUNDARY LINE
 - PROPOSED CURB
 - PROPOSED STRIPING
 - PROPOSED CAST IN PLACE WALL
 - PROPOSED SHARED PATH WALL
 - CONSERVATION EASEMENT AREA
 - PROPOSED GREASE INTERCEPTOR
 - PROPOSED STORM CATCHBASIN
 - PROPOSED STORM CLEANOUT
 - PROPOSED SANITARY CLEANOUT
 - PROPOSED STORM MANHOLE
 - PROPOSED SANITARY MANHOLE
 - PROPOSED FIRE HYDRANT
 - PROPOSED FIRE DEPT. CONNECTION
 - PROPOSED WATER METER
 - PROPOSED COMPOUND METER

PROJECT SUMMARY

MASTER PLAN AREA:	38.72 ACRES
FUTURE DEVELOPMENT AREA: (BY OTHERS)	6.81 ACRES
PRIMARY DEVELOPMENT AREA:	
GROSS AREA:	31.91 ACRES
NATURAL AREA:	6.00 ACRES
NET AREA:	25.91 ACRES
REQUIRED LANDSCAPE AREA:	15% / 4.78 ACRES
LANDSCAPE AREA PROPOSED:	9.03 ACRES
FLOOR AREA RATIO:	0.214
TOTAL PERMISSIBLE BUILDING AREA:	307,000 SF
BUILDING	AREA
BLDG 1005	30,000 SF
BLDG 1010	21,750 SF
BLDG 1030	2,900 SF
BLDG 1040	110,000 SF
BLDG A	12,500 SF
BLDG B	5,850 SF
BLDG C	3,950 SF
BLDG D	32,459 SF
BLDG E	3,285 SF
BLDG F	5,500 SF
BLDG G-100	6,200 SF
BLDG H-100	4,679 SF
BLDG J-100	5,734 SF
BLDG M-100	8,000 SF
BLDG N-100	45,000 SF
TOTAL:	297,807 SF
ADDITIONAL POTENTIAL BUILDING AREA:	9,193 SF
TOTAL PROVIDED STALLS:	1,299 STALLS
PARKING RATIO:	4.36/1,000 SF
PARKING STALL	STANDARD 9-FT X 19-FT
DIMENSIONS:	COMPACT 7.7-FT X 16-FT

NOTES:
 1) "SITE AREA" INCLUDES ONLY THE AREAS OF TUALATIN URBAN RENEWAL BLOCKS THAT ARE SUBJECT OF THIS DEVELOPMENT PROPOSAL. OTHER PHASES OF THE MASTER PLAN MAY BE DEVELOPED BY OTHERS.
 2) REQUIRED LANDSCAPING BASED ON GROSS SITE AREA
 3) BUILDING AREAS LISTED IN TABLE MAY DIFFER FROM ACTUAL FOOTPRINT SIZE TO ALLOW FOR INTERIOR WALLS AND ARCHITECTURAL ELEMENTS.

Cardno
 Shaping the Future
 PORTLAND
 5415 SW WESTGATE DR. STE 100, PORTLAND, OR 97221
 TEL: (503) 419-2500 FAX: (503) 419-2600
 www.cardno.com

CENTERCAL
 PERMANENT, LLC

Perkowitz + Ruth
 ARCHITECTS

SITE PLAN
NYBERG RIVERS MASTER PLAN
 TUALATIN, OREGON

PROJECT NO.: 21198310
 DATE: 04/08/13
 DESIGNED BY: RG
 DRAWN BY: RG
 CHECKED BY: JRS

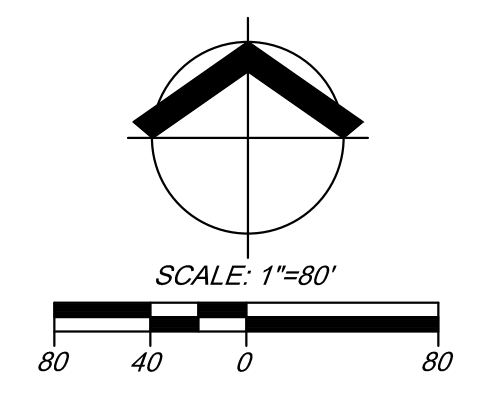

SITE PLAN
C1.0

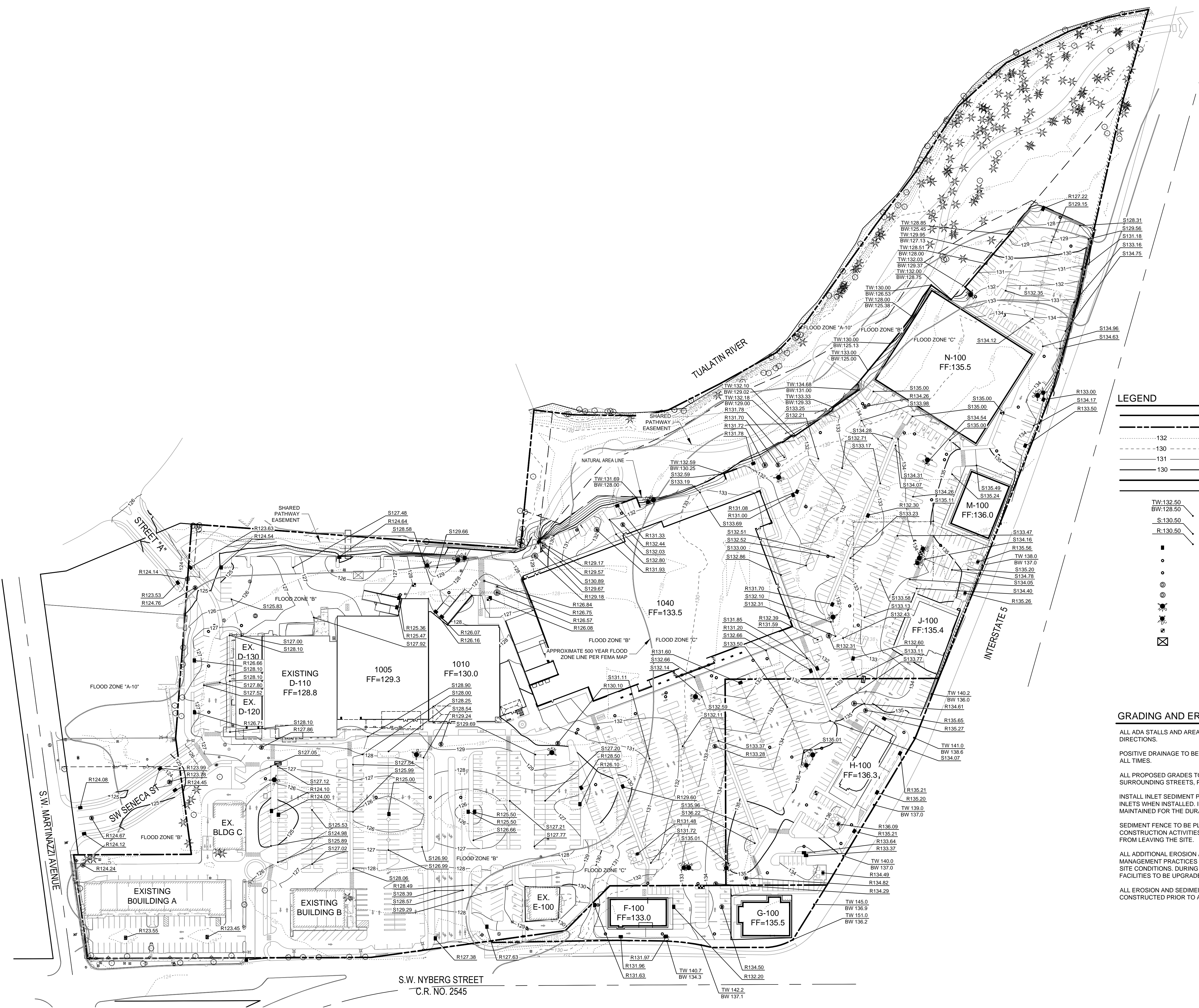

LEGEND

	PROPOSED BUILDING LINE
	EXISTING BOUNDARY LINE
	EXISTING MINOR CONTOUR
	EXISTING MAJOR CONTOUR
	PROPOSED MINOR CONTOUR
	PROPOSED MAJOR CONTOUR
	PROPOSED CAST IN PLACE WALL
	PROPOSED SHARED PATH WALL
	PROPOSED TOP OF WALL, BOTTOM OF WALL
	PROPOSED SPOT SHOT
	PROPOSED RIM SHOT
	PROPOSED STORM CATCHBASIN
	PROPOSED STORM CLEANOUT
	PROPOSED SANITARY CLEANOUT
	PROPOSED STORM MANHOLE
	PROPOSED SANITARY MANHOLE
	PROPOSED FIRE HYDRANT
	PROPOSED FIRE DEPT. CONNECTION
	PROPOSED WATER METER
	PROPOSED COMPOUND METER

GRADING AND EROSION CONTROL NOTES

ALL ADA STALLS AND AREAS TO BE GRADES AT 2% MAX IN ALL DIRECTIONS.

POSITIVE DRAINAGE TO BE MAINTAINED AWAY FROM BUILDINGS AT ALL TIMES.

ALL PROPOSED GRADES TO MATCH INTO EXISTING GRADES ON SURROUNDING STREETS, PROPERTIES, AND SENSITIVE AREAS.

INSTALL INLET SEDIMENT PROTECTION ON ALL EXISTING AND NEW INLETS WHEN INSTALLED. INLET SEDIMENT PROTECTION TO BE MAINTAINED FOR THE DURATION OF ALL CONSTRUCTION ACTIVITIES.

SEDIMENT FENCE TO BE PLACED AND MAINTAINED DURING ALL CONSTRUCTION ACTIVITIES TO PREVENT SEDIMENT LADEN WATER FROM LEAVING THE SITE.

ALL ADDITIONAL EROSION AND SEDIMENT CONTROL BEST MANAGEMENT PRACTICES SHALL BE IMPLEMENTED FOR ANTICIPATED SITE CONDITIONS. DURING THE CONSTRUCTION PERIOD. ALL FACILITIES TO BE UPGRADES AS NEEDED FOR STORM EVENTS.

ALL EROSION AND SEDIMENT CONTROL FACILITIES WILL BE CONSTRUCTED PRIOR TO ANY CLEARING AND GRADING ACTIVITIES.

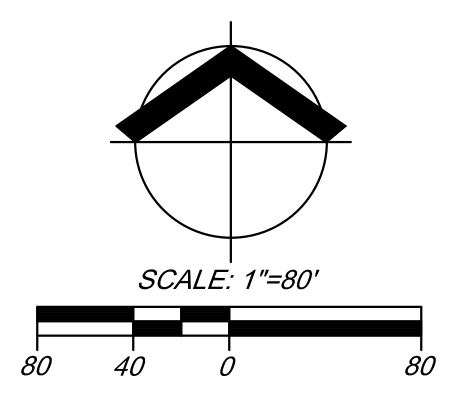

STORM STRUCTURE MANHOLE/VAULT TABLE

SDMH#A1-WQ - 4 CARTRIDGES 72" MANHOLE RIM: 129.57 IE IN (15°NE) = 118.07 IE IN (10°NW) = 118.07 IE OUT (15°SE) = 115.77	SDMH#P6 60" MANHOLE RIM: 134.61 IE IN (18°SW) = 118.84 IE IN (12°SE) = 119.64 IE OUT (24°N) = 116.64
SDMH#E1-WQ - 2 CARTRIDGES 48" MANHOLE RIM: 126.03 IE IN (12°SE) = 122.17 IE OUT (12°NW) = 119.87	SDMH#P7 48" MANHOLE RIM: 134.82 IE IN (12°SW) = 120.78 IE OUT (18°NE) = 120.28
SDMH#F1-WQ - 2 CARTRIDGES 48" MANHOLE RIM: 134.50 IE IN (12°S) = 123.57 IE IN (8°W) = 123.57 IE OUT (12°NE) = 121.27	SDMH#P8-WQ - 1 CARTRIDGE 48" MANHOLE RIM: 124.76 IE IN (12°NW) = 118.16 IE OUT (12°E) = 117.96
SDMH#J1-WQ - 2 CARTRIDGES 48" MANHOLE RIM: 130.17 IE IN (12°S) = 119.68 IE IN (10°W) = 119.68 IE OUT (12°NE) = 117.38	SDMH#P9 48" MANHOLE RIM: 124.14 IE IN (12°W) = 118.56 IE IN (12°N) = 118.56 IE OUT (12°SE) = 118.36
SDMH#M1-WQ - 6 CARTRIDGES 72" MANHOLE RIM: 126.57 IE IN (12°W) = 118.70 IE IN (12°E) = 118.70 IE IN (10°SE) = 120.86 IE OUT (12°NE) = 116.40	SDMH#P10-WQ - 2 CARTRIDGE 48" MANHOLE RIM: 124.97 IE IN (15°SW) = 120.86 IE IN (10°NW) = 120.86 IE IN (10°SE) = 120.86 IE OUT (12°NE) = 116.40
SDMH#N1-WQ - 2 CARTRIDGES 48" MANHOLE RIM: 124.24	SDMH#P11 48" MANHOLE RIM: 125.49 IE IN (10°SW) = 121.66 IE IN (10°NW) = 121.66 IE OUT (15°NE) = 121.46
SDMH#P1 72" MANHOLE RIM: 126.75 IE IN (24°NE) = 114.80 IE IN (12°S) = 116.30	SDVT#B1-WQ - 15 CARTRIDGES RIM: 131.78 IE IN (18°NE) = 119.96 IE IN (18°SE) = 119.96 IE OUT (18°W) = 117.66
SDMH#P2 72" MANHOLE RIM: 129.18 IE IN (24°NE) = 114.73 IE OUT (24°SW) = 114.97 IE OUT (24°N) = 114.33	SDVT#D1-WQ - 15 CARTRIDGES RIM: 132.39 IE IN (18°W) = 120.58 IE OUT (18°E) = 118.28
SDMH#P3 60" MANHOLE RIM: 131.93 IE IN (24°E) = 115.34 IE OUT (24°SW) = 115.14	SDVT#H1-WQ - 11 CARTRIDGES RIM: 125.47 IE IN (18°S) = 119.68 IE IN (12°E) = 119.68 IE OUT (18°N) = 117.38
SDMH#P4 60" MANHOLE RIM: 131.72 IE IN (18°E) = 116.95 IE IN (24°S) = 116.65 IE OUT (24°W) = 116.45	
SDMH#P5 60" MANHOLE RIM: 132.31 IE IN (24°S) = 118.13 IE IN (18°W) = 118.13 IE OUT (24°N) = 117.93	

STORM STRUCTURE CATCHBASIN TABLE

SDCB#D1 RIM: 129.17 IE OUT (10°S) = 125.17	SDCB#D3 RIM: 131.60 IE OUT (12°N) = 127.60	SDCB#F4 RIM: 126.16 IE OUT (8°E) = 127.63	SDCB#M2 RIM: 126.16 IE IN (12°SE) = 119.96 IE OUT (12°N) = 119.96
SDCB#A2 RIM: 131.33 IE OUT (10°S) = 127.33	SDCB#D4 RIM: 128.50 IE OUT (12°E) = 124.50	SDCB#G1-WQ - 1 CARTRIDGE RIM: 127.63 IE IN (12°E) = 125.33 IE OUT (8°W) = 125.33	SDCB#M3 RIM: 126.07 IE OUT (12°NW) = 120.06
SDCB#B1 RIM: 131.78 IE OUT (10°E) = 127.79	SDCB#D5 RIM: 129.60 IE OUT (12°W) = 125.60	SDCB#G2-WQ - 1 CARTRIDGE RIM: 127.38 IE OUT (8°E) = 125.08	SDCB#M4 RIM: 125.36 IE IN (12°S) = 120.99 IE OUT (12°N) = 120.99
SDCB#B2 RIM: 133.50 IE OUT (8°W) = 129.50	SDCB#D6 RIM: 126.10 IE OUT (12°E) = 123.55	SDCB#H1 RIM: 124.10 IE OUT (10°W) = 121.20	SDCB#M5 RIM: 125.47 IE OUT (12°N) = 121.33
SDCB#B3 RIM: 133.00 IE OUT (8°W) = 129.00	SDCB#E1 RIM: 135.27 IE OUT (8°SW) = 132.27	SDCB#H2 RIM: 124.00 IE OUT (10°W) = 121.28	SDCB#N1-WQ - 1 CARTRIDGES RIM: 123.55
SDCB#B4 RIM: 127.22 IE OUT (12°SE) = 124.46	SDCB#E2 RIM: 135.21 IE OUT (8°NW) = 132.21	SDCB#H3 RIM: 125.00 IE OUT (12°W) = 121.69	SDCB#N2-WQ - 1 CARTRIDGES RIM: 123.45
SDCB#C1 RIM: 131.08 IE OUT (12°NE) = 127.08	SDCB#E3 RIM: 135.20 IE OUT (8°NW) = 131.20	SDCB#H4 RIM: 125.50 IE OUT (12°W) = 121.50	SDCB#P2 RIM: 123.53 IE OUT (12°NE) = 119.53
SDCB#C2 RIM: 131.00 IE OUT (12°NE) = 127.00	SDCB#E4 RIM: 135.21 IE OUT (8°NW) = 131.21	SDCB#H5 RIM: 125.50 IE OUT (12°N) = 121.50	SDCB#P3 RIM: 124.45 IE OUT (10°NW) = 121.45
SDCB#C3 RIM: 132.30 IE OUT (12°S) = 128.30	SDCB#E5 RIM: 133.37 IE OUT (8°N) = 129.67	SDCB#I1 RIM: 127.35 IE OUT (8°E) = 126.66	SDCB#P4 RIM: 124.45 IE OUT (10°SE) = 121.45
SDCB#C4 RIM: 131.70 IE OUT (12°E) = 127.70	SDCB#E6 RIM: 133.64 IE OUT (8°N) = 129.64	SDCB#J2 RIM: 126.71 IE OUT (8°E) = 125.74	SDCB#P5 RIM: 123.33 IE OUT (12°S) = 121.81
SDCB#C5 RIM: 132.60 IE OUT (12°N) = 128.60	SDCB#F1 RIM: 132.20 IE OUT (8°E) = 128.20	SDCB#K1-WQ - 2 CARTRIDGES RIM: 124.54 IE OUT (12°S) = 120.54	SDCB#P6 RIM: 123.34 IE OUT (12°N) = 121.82
SDCB#D1 RIM: 131.59 IE OUT (12°W) = 128.00	SDCB#F2 RIM: 131.97 IE OUT (8°N) = 127.97	SDCB#L1-WQ - 2 CARTRIDGES RIM: 124.64 IE OUT (12°S) = 120.64	SDTD#A1-WQ - 2 CARTRIDGES RIM: 124.41 IE IN (10°E) = 122.11 IE OUT (10°SW) = 122.11
SDCB#D2 RIM: 131.20 IE OUT (12°N) = 128.00	SDCB#F3 RIM: 131.96 IE OUT (8°N) = 127.96	SDCB#M1 RIM: 126.08 IE OUT (12°N) = 122.08	

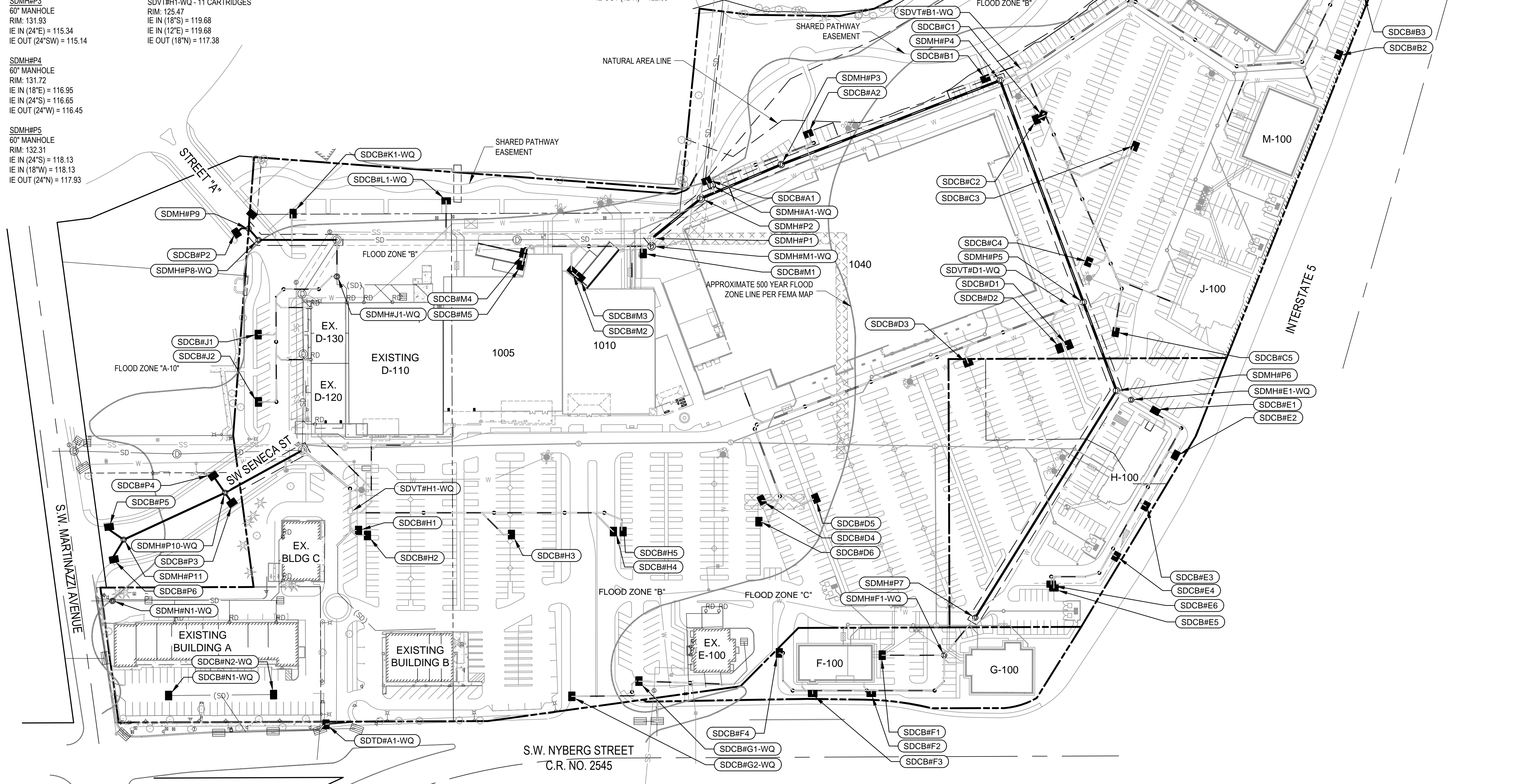

LEGEND

- - - - - PROPERTY LINE
- - - - - LOT LINE
- - - - - EXISTING STORM LINE
- - - - - PROPOSED STORM PRIVATE LINE
- - - - - PROPOSED STORM PUBLIC LINE
- - EXISTING STORM MANHOLE
- - EXISTING STORM CATCH BASIN
- - PROPOSED STORM MANHOLE
- - PROPOSED STORM CATCH BASIN
- - PROPOSED STORM CLEAN OUT
- - - - - EXISTING STORM EASEMENT
- - - - - PROPOSED STORM EASEMENT
- - - - - EXISTING VACATED EASEMENT

Cardno
Shaping the Future

PORTLAND
5415 SW WESTGATE DR. STE 100, PORTLAND, OR 97221
TEL: (503) 419-2500 FAX: (503) 419-2800
www.cardno.com

CENTERCAL
PROPERTIES, LLC

Perkowitz + Ruth
ARCHITECTS

STORM PLAN
NYBERG RIVERS MASTER PLAN
TUALATIN, OREGON

PROJECT NO.: 21198310
DATE: 04/08/13
DESIGNED BY: KDD
DRAWN BY: KDD
CHECKED BY: JRS

STORM PLAN
C3.0

MANHOLE DATA

SSMH#1(EX) RIM: 127.81 IE IN (8"E) = 118.29	SSMH#3 RIM: 130.10 IE IN (8"E) = 121.80 IE IN (8"E) = 121.80 IE OUT (8"W) = 121.60
SSMH#2 RIM: 131.70 IE IN (8"NE) = 124.91 IE OUT (8"W) = 124.71	SSMH#4 RIM: 129.24 IE IN (8"E) = 120.58 IE OUT (8"W) = 120.38
SSMH#3 RIM: 132.44 IE IN (8"E) = 123.25 IE OUT (8"W) = 123.05	SSMH#5 RIM: 127.86 IE IN (8"E) = 118.81 IE OUT (8"W) = 118.61
SSMH#4 RIM: 126.84 IE IN (8"E) = 121.74 IE IN (6"S) = 121.74	
SSMH#P1 RIM: 134.29 IE IN (6"W) = 125.99 IE IN (6"E) = 125.99 IE OUT (8"N) = 125.79	
SSMH#P2 RIM: 133.28 IE IN (6"E) = 123.38 IE IN (8"S) = 123.38 IE OUT (8"W) = 123.18	

CATCH BASIN DATA

SSCB#A1 RIM: 135.26 IE OUT (6"W) = 132.26	SSCB#A2 RIM: 135.56 IE OUT (6"W) = 132.56
SSCB#C1 RIM: 136.09 IE OUT (6"WW) = 133.09	SSCB#D1 RIM: 131.48 IE IN (6"S) = 127.12
SSCB#D2 RIM: 134.49 IE OUT (6"W) = 131.49	

GREASE INTERCEPTOR DATA

SSGI#A1 RIM: 134.38 IE IN (6"E) = 129.55 IE OUT (6"W) = 129.38	SSGI#D1 RIM: 134.65 IE IN (6"E) = 127.00 IE OUT (6"W) = 126.83
SSGI#A2 RIM: 135.34 IE IN (6"E) = 128.53 IE OUT (6"W) = 128.36	SSGI#D2 RIM: 132.39 IE IN (6"S) = 127.68 IE OUT (6"N) = 127.51
SSGI#B1 RIM: 132.39 IE IN (6"E) = 122.46 IE OUT (6"W) = 122.29	SSGI#N1 RIM: 127.54 IE IN (4"N) = 120.84 IE OUT (4"S) = 120.67
SSGI#C1 RIM: 135.54 IE IN (6"SE) = 125.68 IE OUT (6"NW) = 125.51	SSGI#N2 RIM: 127.30 IE IN (4"N) = 122.43 IE OUT (4"S) = 122.26

LEGEND

- PROPERTY LINE
- LOT LINE
- SS --- EXISTING SANITARY LINE
- PROPOSED SANITARY PRIVATE LINE
- PROPOSED SANITARY PUBLIC LINE
- --- EXISTING SANITARY MANHOLE
- --- PROPOSED PUBLIC MANHOLE
- --- PROPOSED PRIVATE MANHOLE
- --- PROPOSED SANITARY CATCH BASIN
- --- PROPOSED SANITARY CLEAN OUT
- --- PROPOSED GREASE INTERCEPTOR
- EXISTING SANITARY EASEMENT
- PROPOSED SANITARY EASEMENT
- EXISTING VACATED EASEMENT

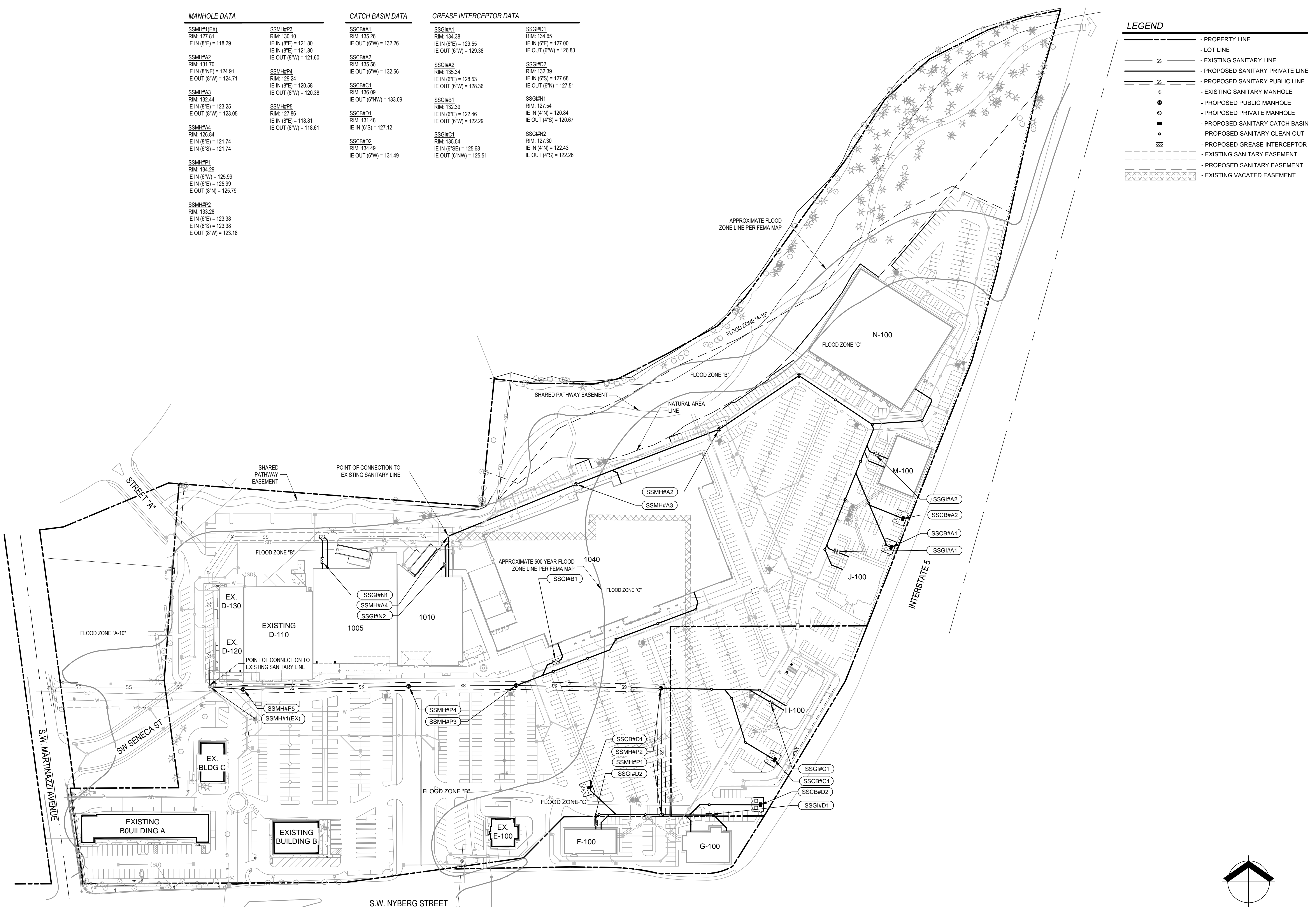

SANITARY PLAN
NYBERG RIVERS MASTER PLAN
TUALATIN, OREGON

PROJECT NO.: 21198310
DATE: 04/08/13
DESIGNED BY: MJZ
DRAWN BY: MJZ
CHECKED BY: JRS

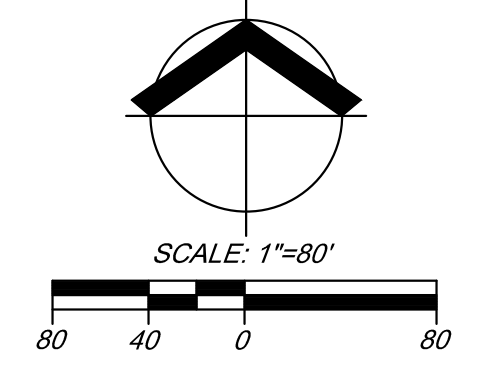

SANITARY PLAN
C4.0

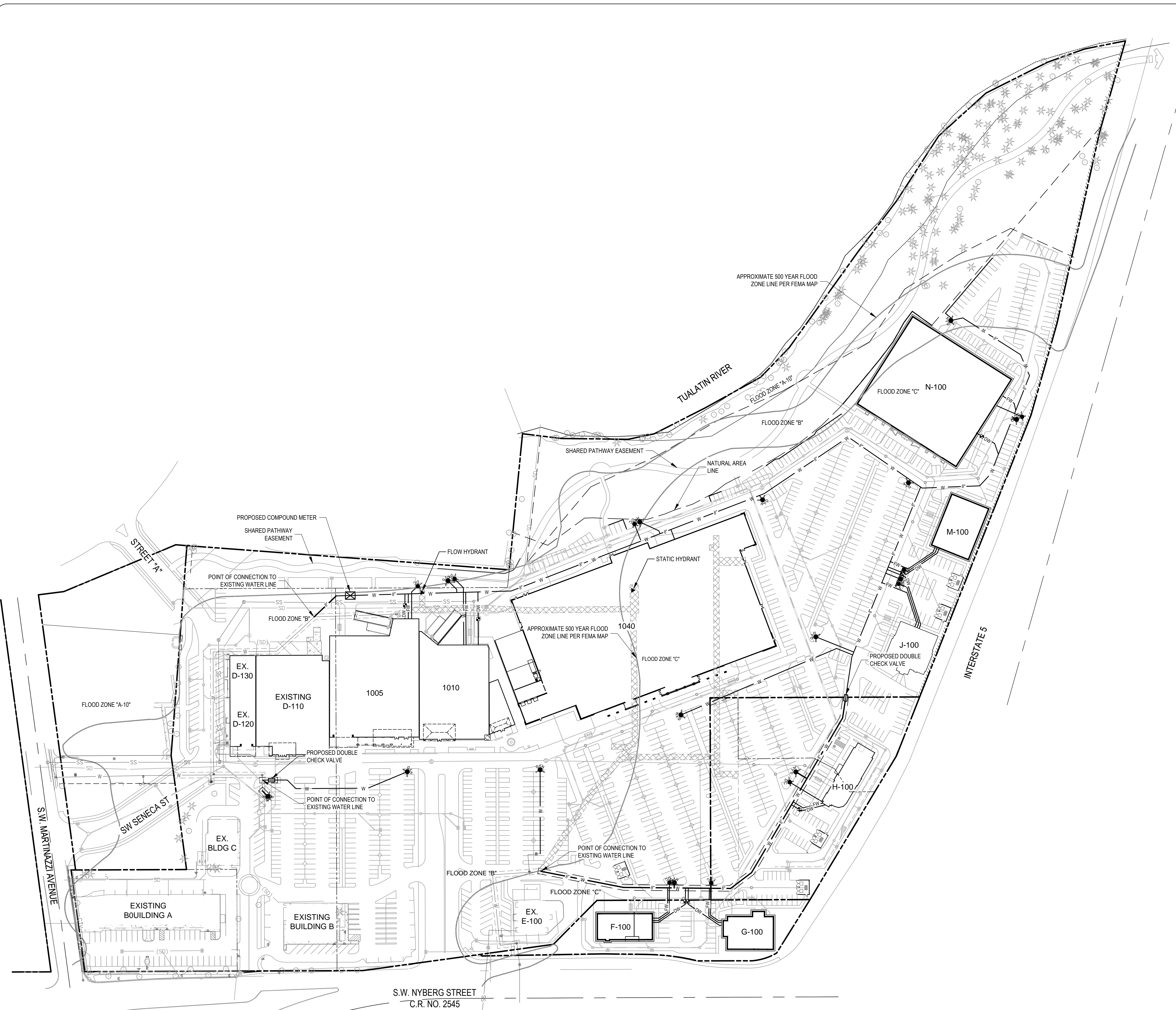

LEGEND

- PROPERTY LINE
- LOT LINE
- EXISTING WATER LINE
- PROPOSED WATER PRIVATE LINE
- PROPOSED WATER PUBLIC LINE
- PROPOSED FIRE WATER LINE
- PROPOSED DOMESTIC WATER LINE
- EXISTING FIRE HYDRANT
- EXISTING WATER METER
- EXISTING WATER VAULT
- EXISTING WATER VALVE
- PROPOSED FIRE HYDRANT
- PROPOSED FIRE DEPT. CONNECTION
- PROPOSED WATER METER
- PROPOSED COMPOUND METER
- PROPOSED DOUBLE CHECK VALVE
- EXISTING WATER EASEMENT
- PROPOSED WATER EASEMENT
- EXISTING VACATED EASEMENT
- EXISTING FIRE FLOW HYDRANT

WATER GENERAL NOTES:

1. ALL DOMESTIC WATER METERS SHALL BE RESIZED PER BUILDINGS PROJECTED WATER USAGE.
2. ALL DOMESTIC WATER LINES TO BE METERED AND BACKFLOWS TO BE PROVIDED INSIDE THE BUILDING.
3. ALL FIRE DEPARTMENT CONNECTIONS WILL BE WITHIN 100' OF A FIRE HYDRANT.
4. ALL FIRELINE BACKFLOW TO BE PROVIDED INSIDE THE BUILDING.

EXISTING FIRE FLOW TEST DATA:
 TEST DATE: 3/18/2013

STATIC HYDRANT: NYBERG ROAD
 (SEE PLAN LOCATION)

FLOW HYDRANT: NYBERG ROAD
 (SEE PLAN LOCATIONS)

STATIC PRESSURE = 70 PSI

RESIDUAL PRESSURE = 66 PSI

FLOW = 949 GPM

PRESSURE = 20 PSI

AVAILABLE FLOW = 3712 GPM

S.W. NYBERG STREET
 C.R. NO. 2545

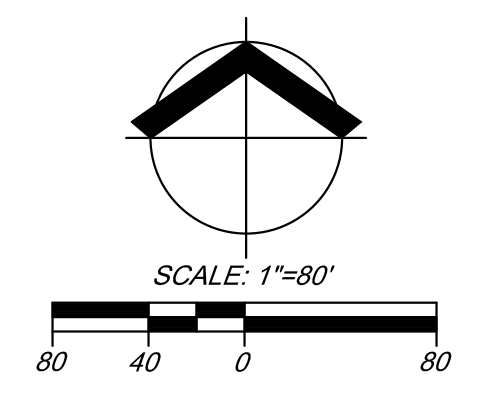

LANDSCAPE PLANT MATERIAL SCHEDULE

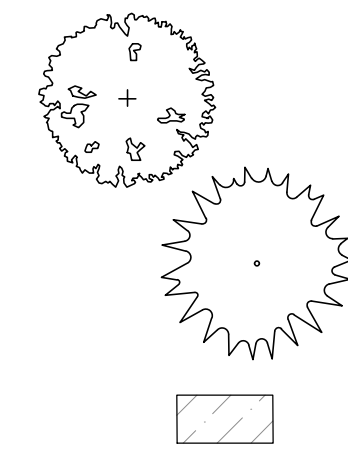

TUALATIN RIVER PLANTINGS	SIZE	QTY.
DECIDUOUS TREES OREGON WHITE OAK WESTERN DOGWOOD WESTERN HAWTHORNE PAPER BIRCH	2" CAL. / B&B AS SHOWN	339
EVERGREEN TREES WESTERN RED CEDAR DOUGLAS FIR	6-7' HT. / B&B AS SHOWN	29
SHRUBS / GROUNDCOVER BEARBERRY OREGON GRAPE HOLLY NOOTKA ROSE SEDGES AND RUSHES	1-3 GAL.	

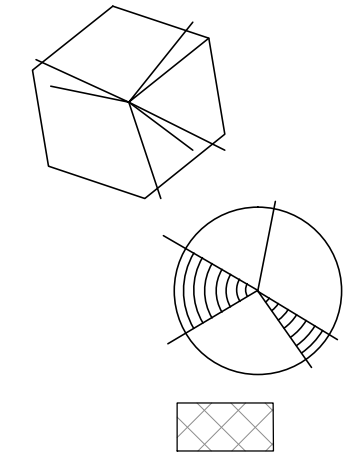

CENTRAL OREGON PLANTINGS	SIZE	QTY.
DECIDUOUS TREES RIVER BIRCH THORNLESS HONEYLOCUST TOBA HAWTHORNE SERVICEBERRY	2" CAL. / B&B AS SHOWN	109
EVERGREEN TREES BRISTLECONE PINE ALPINE FIR	6-7' HT. / B&B AS SHOWN	23
SHRUBS / GROUNDCOVER RABBITBUSH BIG SAGE MOUNTAIN MAHOGANY POTENTILLA PIONEER JUNIPER	1-3 GAL.	

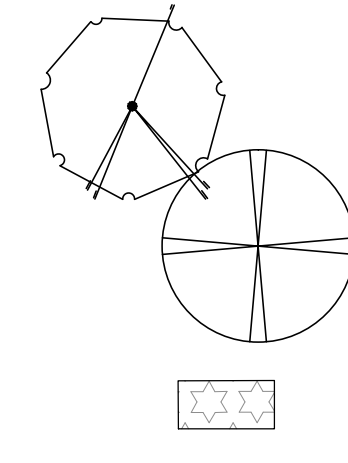

COAST RANGE PLANTINGS	SIZE	QTY.
DECIDUOUS TREES COAST LIVE OAK BEACH PLUM	2" CAL. / B&B AS SHOWN	38
EVERGREEN TREES SHORE PINE MADRONE	6-7' HT. / B&B AS SHOWN	3
SHRUBS / GROUNDCOVER BEACH ROSE PACIFIC WAX MYRTLE SALAL BUNCHBERRY AMERICAN DUNEGRASS	1-3 GAL.	



GENERAL NOTES: LANDSCAPE PLAN

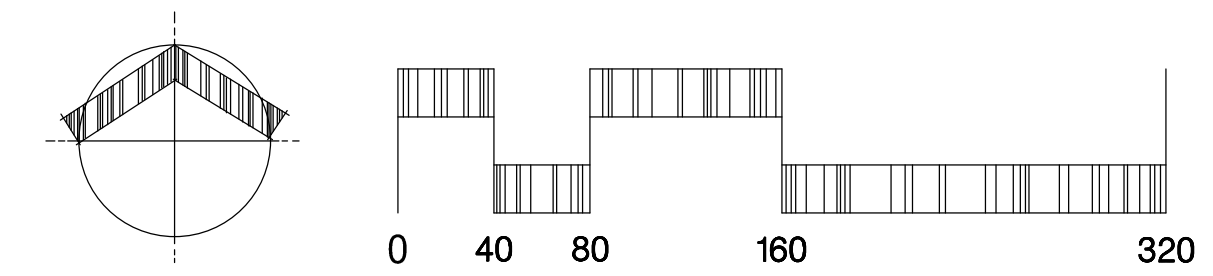

- LANDSCAPE PLANTING SHALL CONFORM TO THE STANDARDS ESTABLISHED UNDER CITY OF TUALATIN PLANNING DEPT.
- ALL PLANT BEDS SHALL HAVE A 3" DEPTH OF BARK MULCH.
- LANDSCAPE AREAS SHALL HAVE A COMPLETE UNDERGROUND AUTOMATIC IRRIGATION SYSTEM WITH FULL HEAD TO HEAD COVERAGE.
- ALL PLANT MATERIAL DELIVERED TO THIS SITE SHALL MEET THE AMERICAN NURSERYMAN'S ASSOCIATION STANDARDS.
- CONTRACTOR SHALL OBTAIN WRITTEN APPROVAL FOR ALL PLANT MATERIAL SUBSTITUTIONS FROM THE LANDSCAPE ARCHITECT PRIOR TO INSTALLATION. PLANT SUBSTITUTIONS WITHOUT PRIOR WRITTEN APPROVAL THAT DO NOT COMPLY WITH THE DRAWINGS AND SPECIFICATIONS MAY BE REJECTED BY THE LANDSCAPE ARCHITECT AT NO COST TO THE OWNER. THESE ITEMS MAY BE REQUIRED TO BE REPLACED WITH PLANT MATERIALS THAT ARE IN COMPLIANCE WITH THE DRAWINGS.



Community Plan Map -Planning Districts- Map 9-1

NOTES:

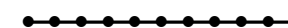

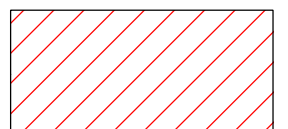

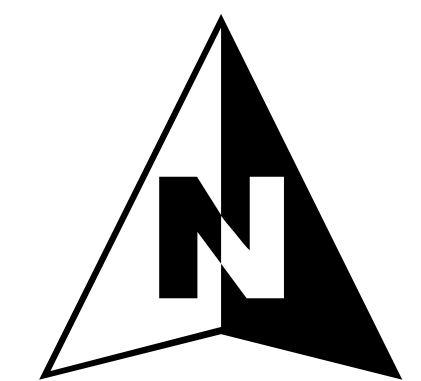
1. All plan designation boundaries are intended to follow property lines, center lines of streets, or can be scaled pursuant to the scale of this map. If mapping errors occur, the City Council shall be the sole arbitration body to decide the location of boundaries.
2. Specific requirements for each Planning District are found within the Tualatin Development Code.
3. The Wetland Protection District and the Greenway and Riverbank Protection District locations are described in the Tualatin Development Code. Maps of the districts are available from the Planning Department.
4. Properties within the Tualatin Urban Renewal Area boundary are subject to the Tualatin Urban Renewal Plan which may contain specifications and requirements that are more restrictive than those found within the Planning District standards.





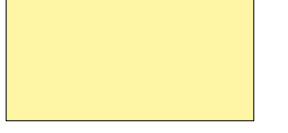



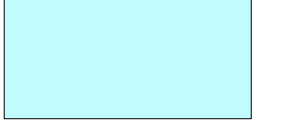

-  Planning Area Boundary
-  Manufactured Dwelling Park Permitted
-  City Boundary
-  In Planning Area/ Outside of City



RF 1:9,600

Effective: May 25, 2011

RESIDENTIAL		DU/Acre
	RL Low Density	1-6.4
	RML Medium-Low Density	7-10
	RMH Medium-High Density	11-15
	RH High Density	16-25
	RH/HR High Density/High Rise	26-30

MANUFACTURING	COMMERCIAL
 ML Light	 CO Office
 MG General	 CC Central
 MP Park	 CG General
 MBP Business Park	 CR Recreational
INSTITUTIONAL	 MC Medical Center
 IN Institutional	

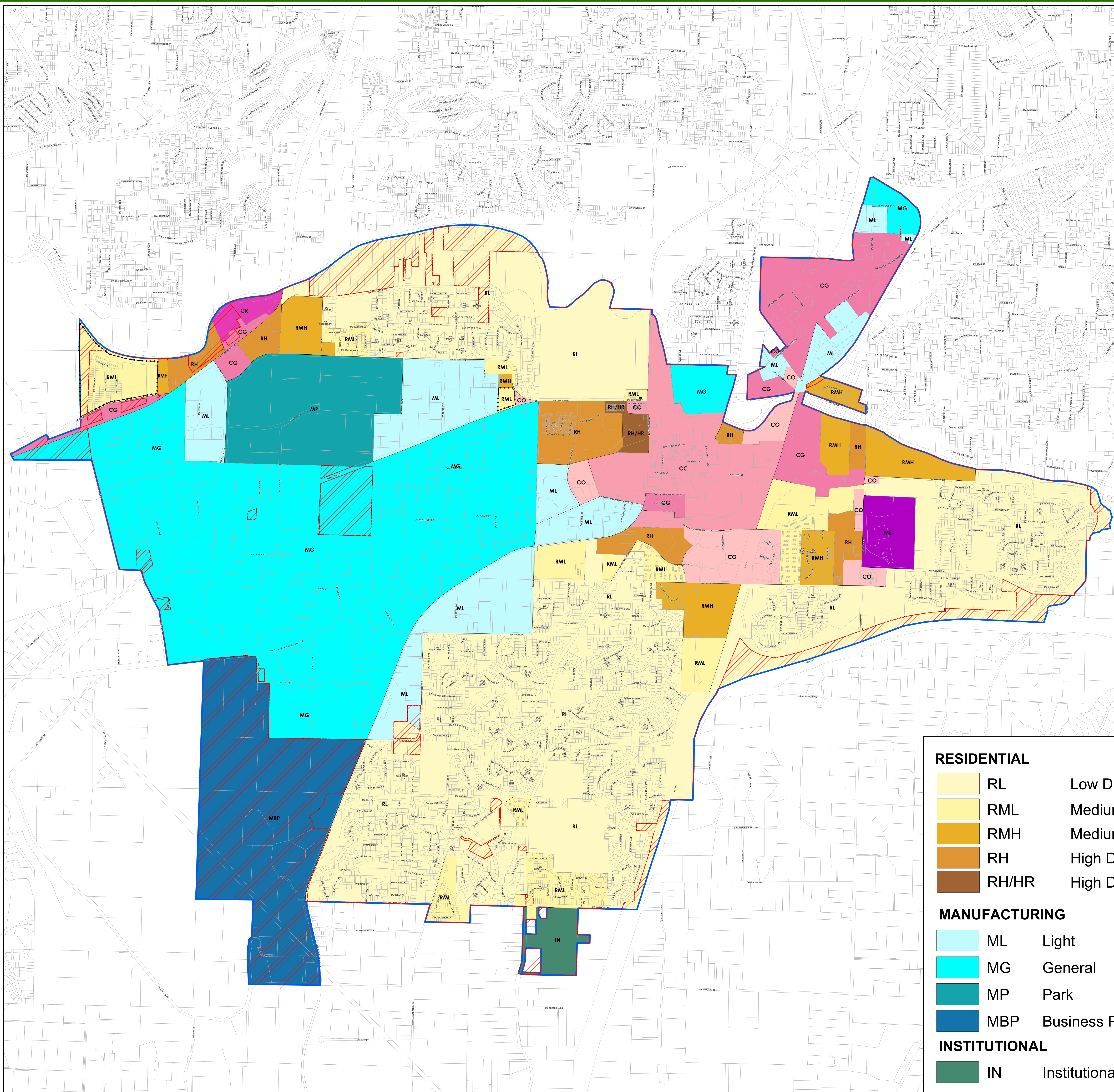

This map is derived from various digital databasesources. While an attempt has been made to provide an accurate map, the City of Tualatin assumes no responsibility or liability for any errors or omissions in the information. This map is provided "as is". -Engineering and Building Dept. J:/Maps/TDC/TDCMap 11-5 Tualatin Bicycle Plan.mxd: Effective July 28, 2005 Printed July 23, 2007

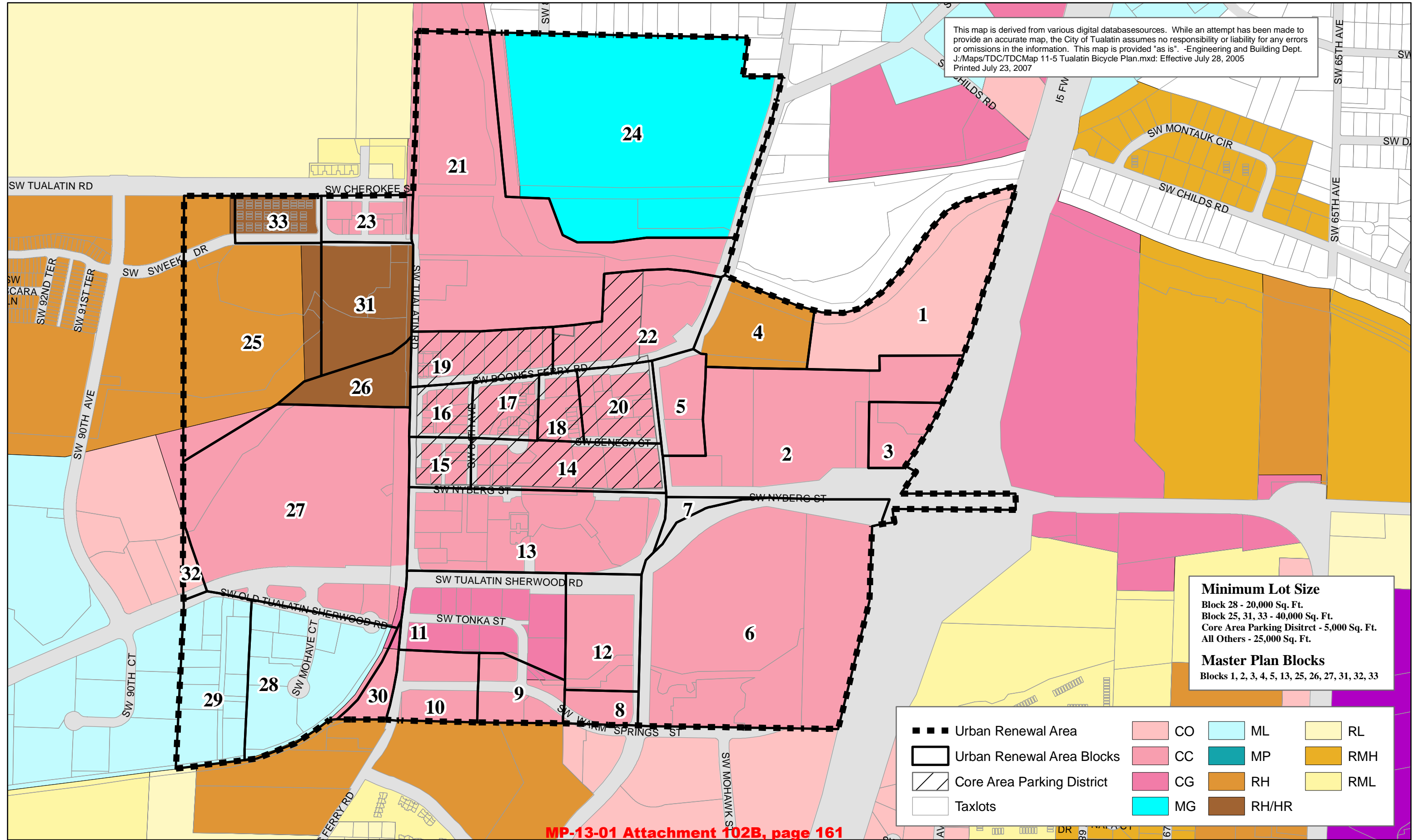



Minimum Lot Size
 Block 28 - 20,000 Sq. Ft.
 Block 25, 31, 33 - 40,000 Sq. Ft.
 Core Area Parking Disitret - 5,000 Sq. Ft.
 All Others - 25,000 Sq. Ft.

Master Plan Blocks
 Blocks 1, 2, 3, 4, 5, 13, 25, 26, 27, 31, 32, 33

■ ■ ■ Urban Renewal Area	CO	ML	RL
▭ Urban Renewal Area Blocks	CC	MP	RMH
▨ Core Area Parking District	CG	RH	RML
□ Taxlots	MG	RH/HR	

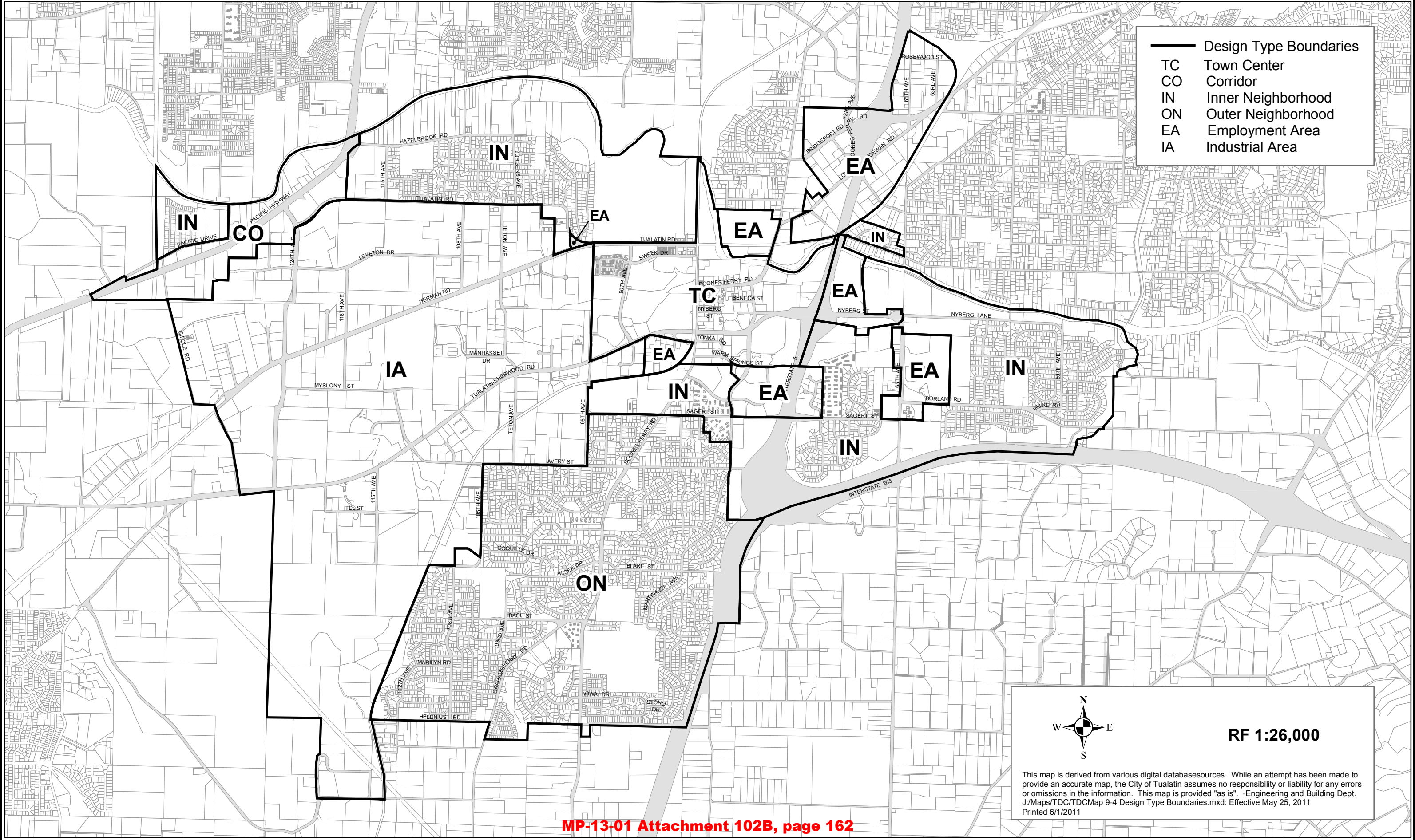
Map 9-4: Design Type Boundaries









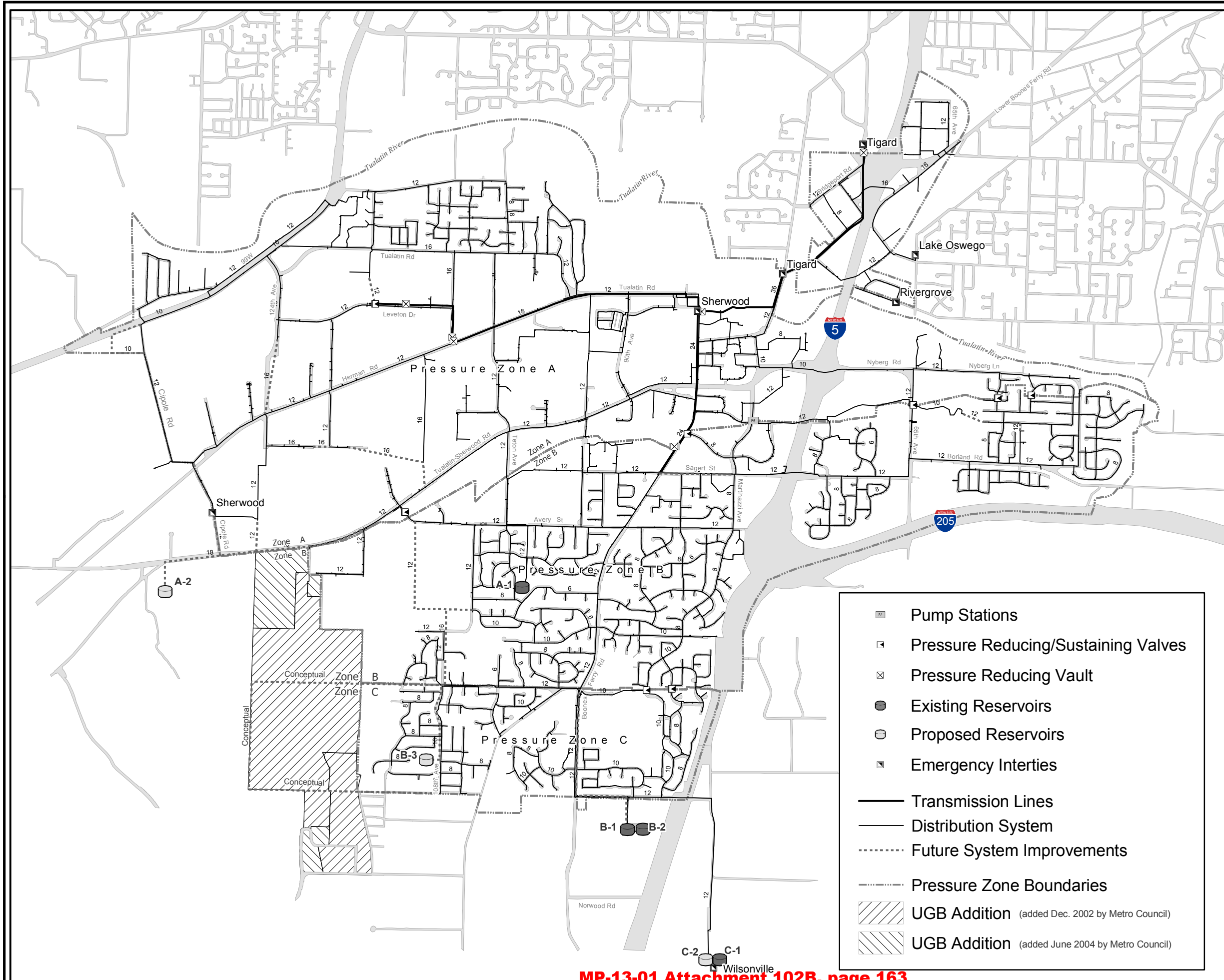







RF 1:26,000

This map is derived from various digital databasesources. While an attempt has been made to provide an accurate map, the City of Tualatin assumes no responsibility or liability for any errors or omissions in the information. This map is provided "as is". -Engineering and Building Dept. J:\Maps\TDC\TDCMap 9-4 Design Type Boundaries.mxd: Effective May 25, 2011 Printed 6/1/2011



-  Pump Stations
-  Pressure Reducing/Sustaining Valves
-  Pressure Reducing Vault
-  Existing Reservoirs
-  Proposed Reservoirs
-  Emergency Interties
-  Transmission Lines
-  Distribution System
-  Future System Improvements
-  Pressure Zone Boundaries
-  UGB Addition (added Dec. 2002 by Metro Council)
-  UGB Addition (added June 2004 by Metro Council)

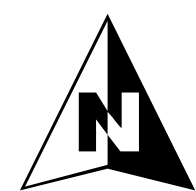

RF 1:28,000

This map is derived from various digital database sources. While an attempt has been made to provide an accurate map, the City of Tualatin assumes no responsibility or liability for any errors or omissions in the information. This map is provided "as is". -Engineering and Building Department Effective July 28, 2005 Printed July 28, 2005

Map 13-1: Sewer System Master Plan

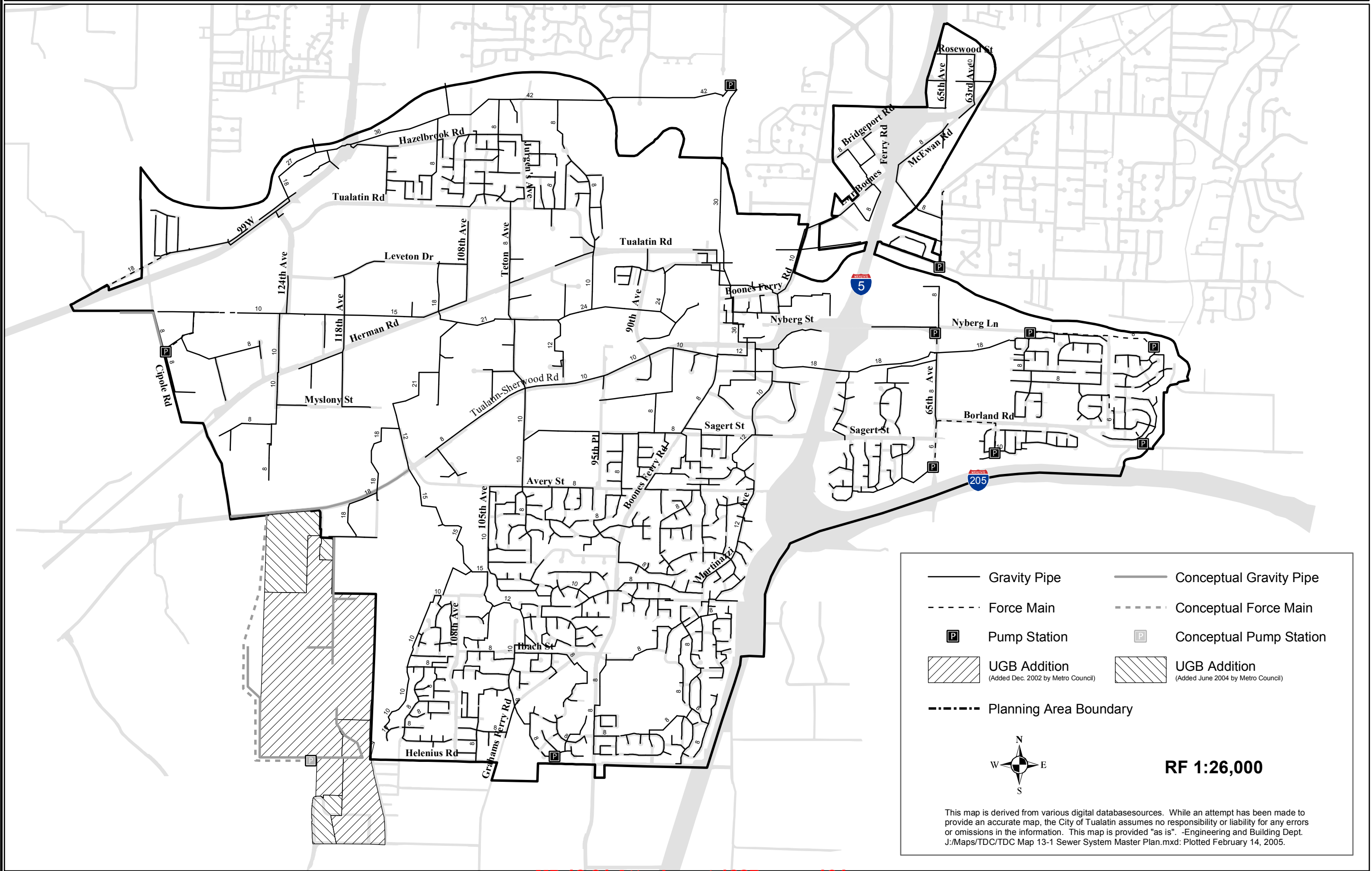

Map 74-1: Street Tree Plantings

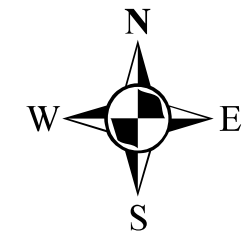
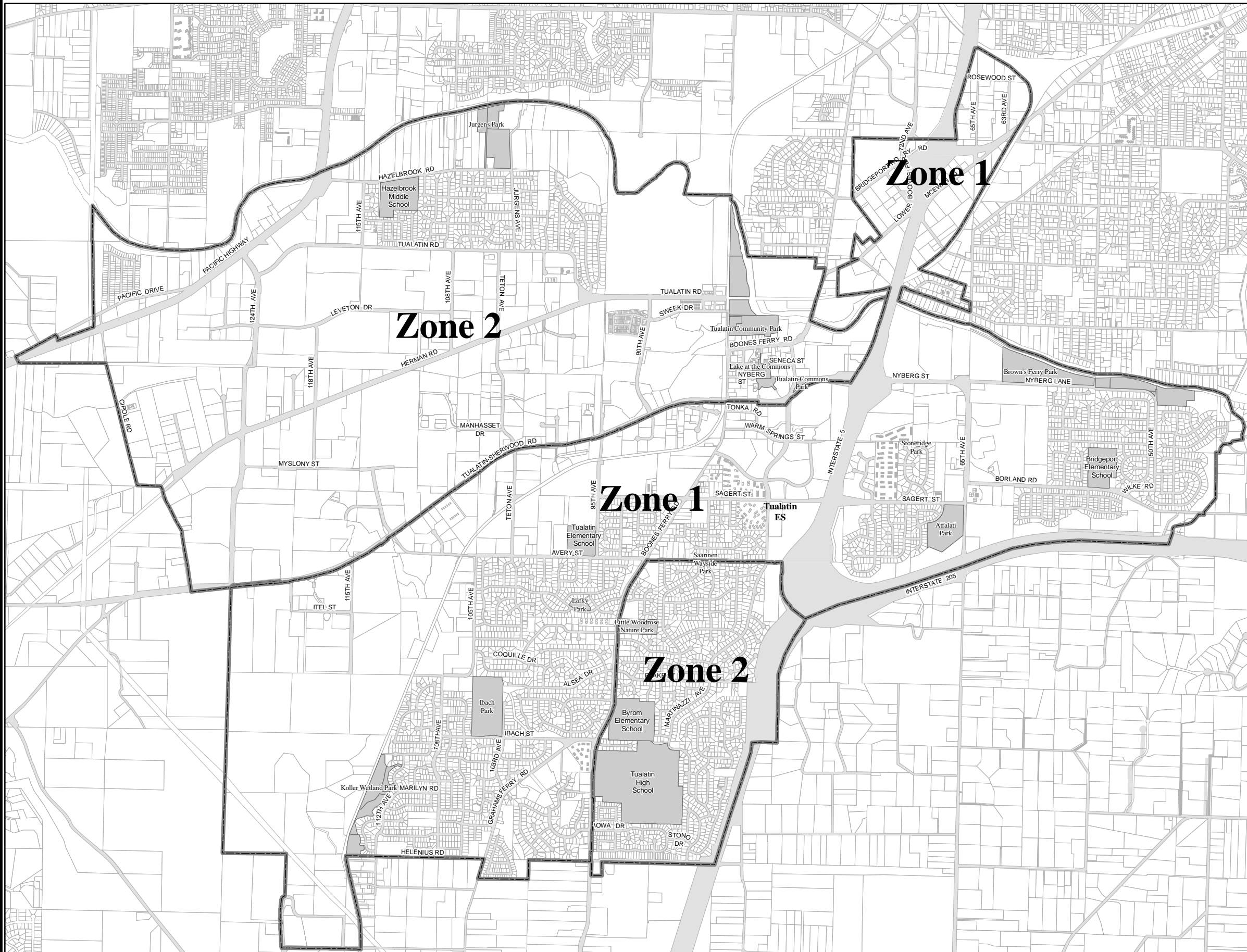

RF 1:26,000

	Street Tree Zones
	Parks & Schools

Zone 1

- | | | |
|------------------------------|-----------------------------------|--------------------------------------|
| 4 Foot Planter Strips | 5 to 6 Foot Planter Strips | 6 Foot or More Planter Strips |
| Leprechaun Ash | Any of the listing above, plus: | Any of the listing above |
| Purple Beech | Shademaker Honey Locust | |
| European Hornbeam | Autumn Applause Ash | |
| Armstrong Maple | | |
| Scanlon/Bowhall Maple | | |
| Skyrocket English Oak | | |
| Capital Flowering Pear | | |
| Persian Parrotia | | |
| Eastern Redbud | | |
| Zelkova Musashino | | |

Zone 2

- | | | |
|------------------------------|-----------------------------------|--------------------------------------|
| 4 Foot Planter Strips | 5 to 6 Foot Planter Strips | 6 Foot or More Planter Strips |
| Golden Desert Ash | Any of the listings above, plus: | Any of the listing above, plus: |
| Leprechaun Ash | Raywood Ash | Tri-Color Beech |
| Purple Beech | Urbanite Ash | Frontier Elm |
| Goldenrain | Ginko | Globe Sugar Maple |
| European Hornbeam | Greenspire Linden | Red Sunset Maple |
| Ivory Japanese Lilac | Crimson King Maple | Red Oak |
| Amur Maackia | | Scarlet Oak |
| Amur Maple | | |
| Crimson Sentry Maple | | |
| Trident Maple | | |
| Skyrocket English Oak | | |
| Persian Parrotia | | |
| Eastern Redbud | | |
| Yellowwood | | |

This map is derived from various digital databasesources. While an attempt has been made to provide an accurate map, the City of Tualatin assumes no responsibility or liability for any errors or omissions in the information. This map is provided "as is". -Engineering and Building Dept.

J:/Maps/TDC/TDC Map 74-1 Street Tree Plantings.mxd
Effective May 25, 2011 Printed 6/1/2011

Map 75-1: Access Management

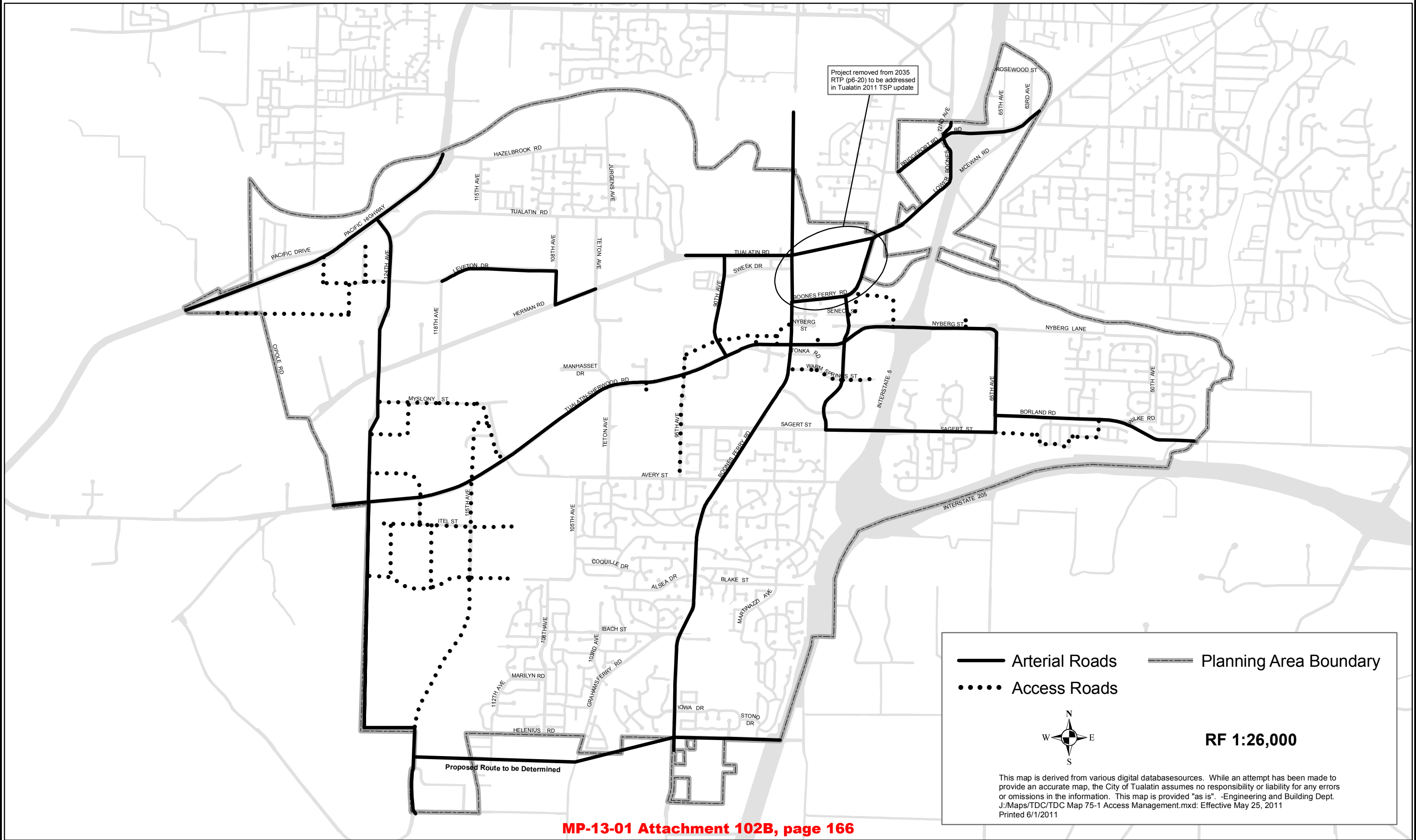

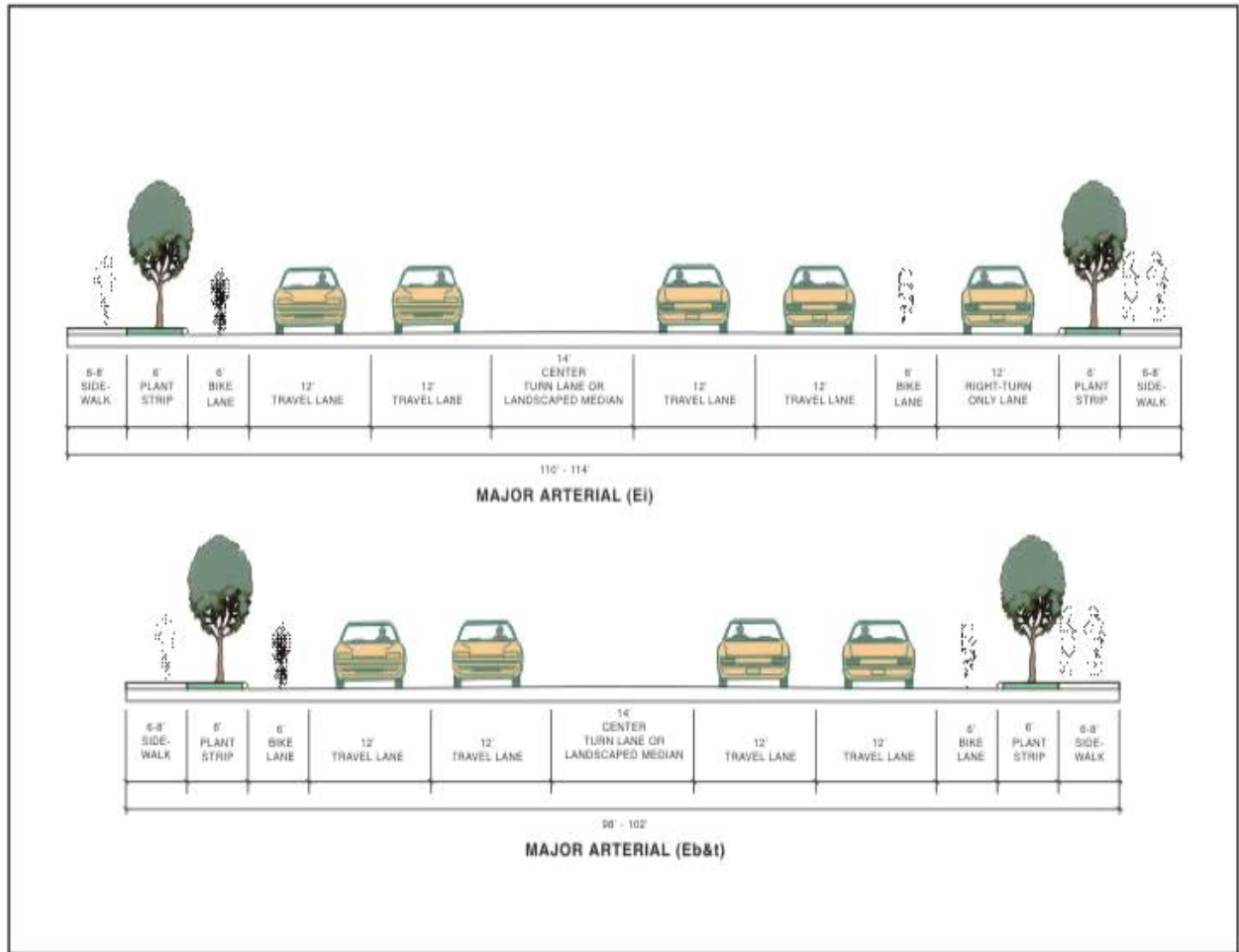

NOTE: TYPICAL RIGHTS-OF WAY AND ULTIMATE CROSS-SECTIONS SHOWN. ADDITIONAL WIDTH MAY BE NEEDED DUE TO TOPOGRAPHICAL CONSTRAINTS OR ADDITIONAL TURN LANES AT INTERSECTIONS. THE PLANTING STRIP DIMENSION INCLUDES A 6" CURB AND GUTTER. INTERIM REDUCED SECTIONS MAY BE CONSTRUCTED WHEN APPROVED BY THE CITY ENGINEER.

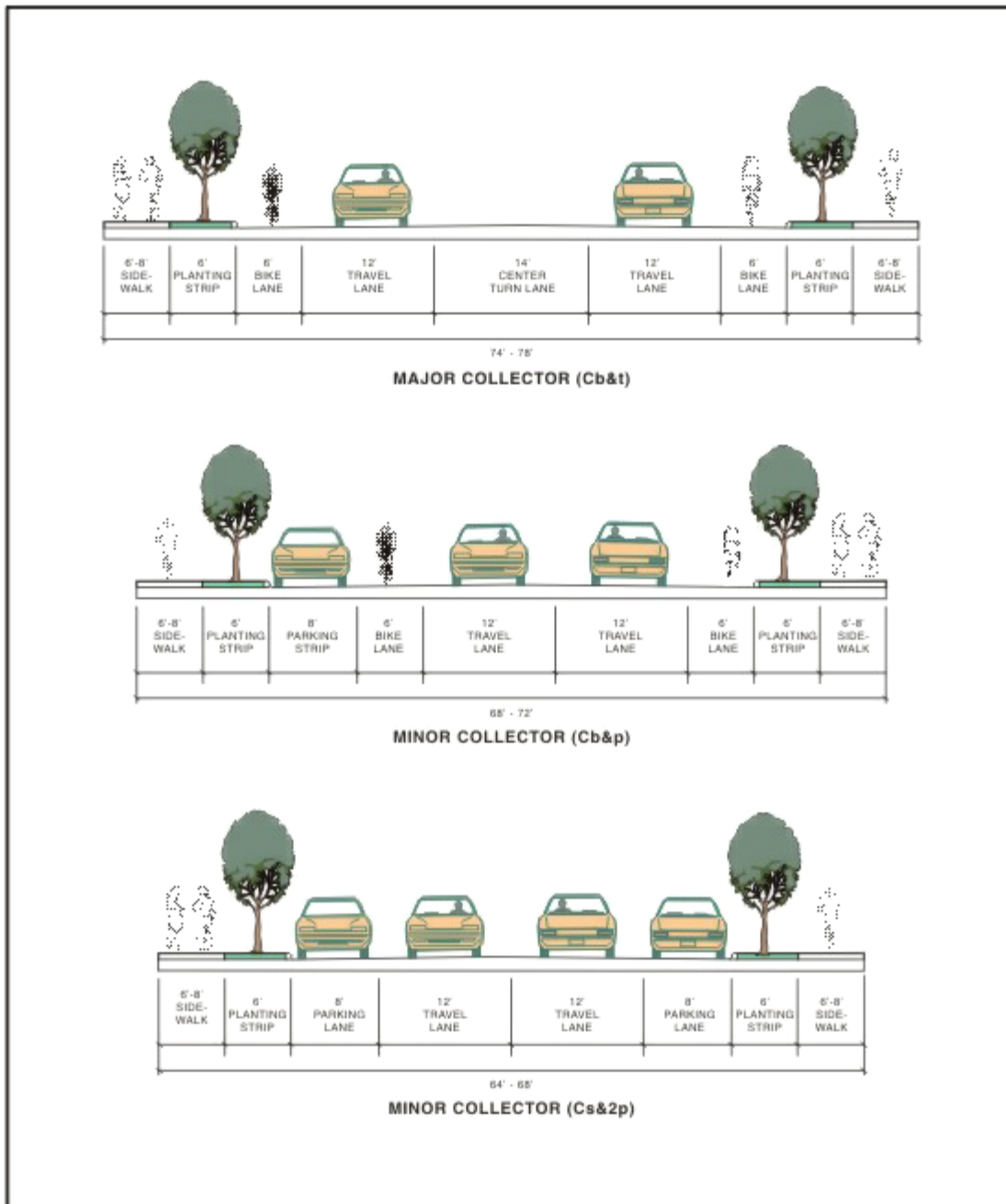

RECOMMENDED ARTERIAL STREET DESIGN STANDARDS (1)

	TRANSPORTATION SYSTEM PLAN CITY OF TUALATIN, OREGON JUNE 2001	FIGURE 75-2B	
	4157GW05T612.DWG		



NOTE: TYPICAL RIGHTS-OF WAY AND ULTIMATE CROSS-SECTIONS SHOWN. ADDITIONAL WIDTH MAY BE NEEDED DUE TO TOPOGRAPHICAL CONSTRAINTS OR ADDITIONAL TURN LANES AT INTERSECTIONS. THE PLANTING STRIP DIMENSION INCLUDES A 6" CURB AND GUTTER. INTERIM REDUCED SECTIONS MAY BE CONSTRUCTED WHEN APPROVED BY THE CITY ENGINEER.

RECOMMENDED COLLECTOR STREET DESIGN STANDARDS (1)

	TRANSPORTATION SYSTEM PLAN CITY OF TUALATIN, OREGON	FIGURE 75-2D	
	JUNE 2001		

4157DWG5T911.DGN

Figure 11-1: Functional Classification Plan

The projects embodied in this map that could affect rivers, streams and wetlands have not been analyzed in terms of Statewide Planning Goal 5 (Natural Resources) as required by Oregon Administrative Rule 660-12-0025(2) and (3)(b). Thus, prior to construction a Goal 5 analysis will be completed and proper permits obtained.

Potential STA/UBA:
Boones Ferry Road from the Tualatin River to Warm Springs Street has been identified for a potential STA/UBA classification.

Project removed from 2035 RTP (p6-20) to be addressed in Tualatin 2011 TSP update

The project at 65th river crossing is designated as a study area. Alternate crossing locations will be considered as part of the design of the project.

Proposed I-5/Highway 99W Connector
Subject to an exception approval from LCDC, a northern alignment is shown. A southern alignment, including an interchange with a SW 124th Avenue extension, is preferred, subject to obtaining a state goals exception.

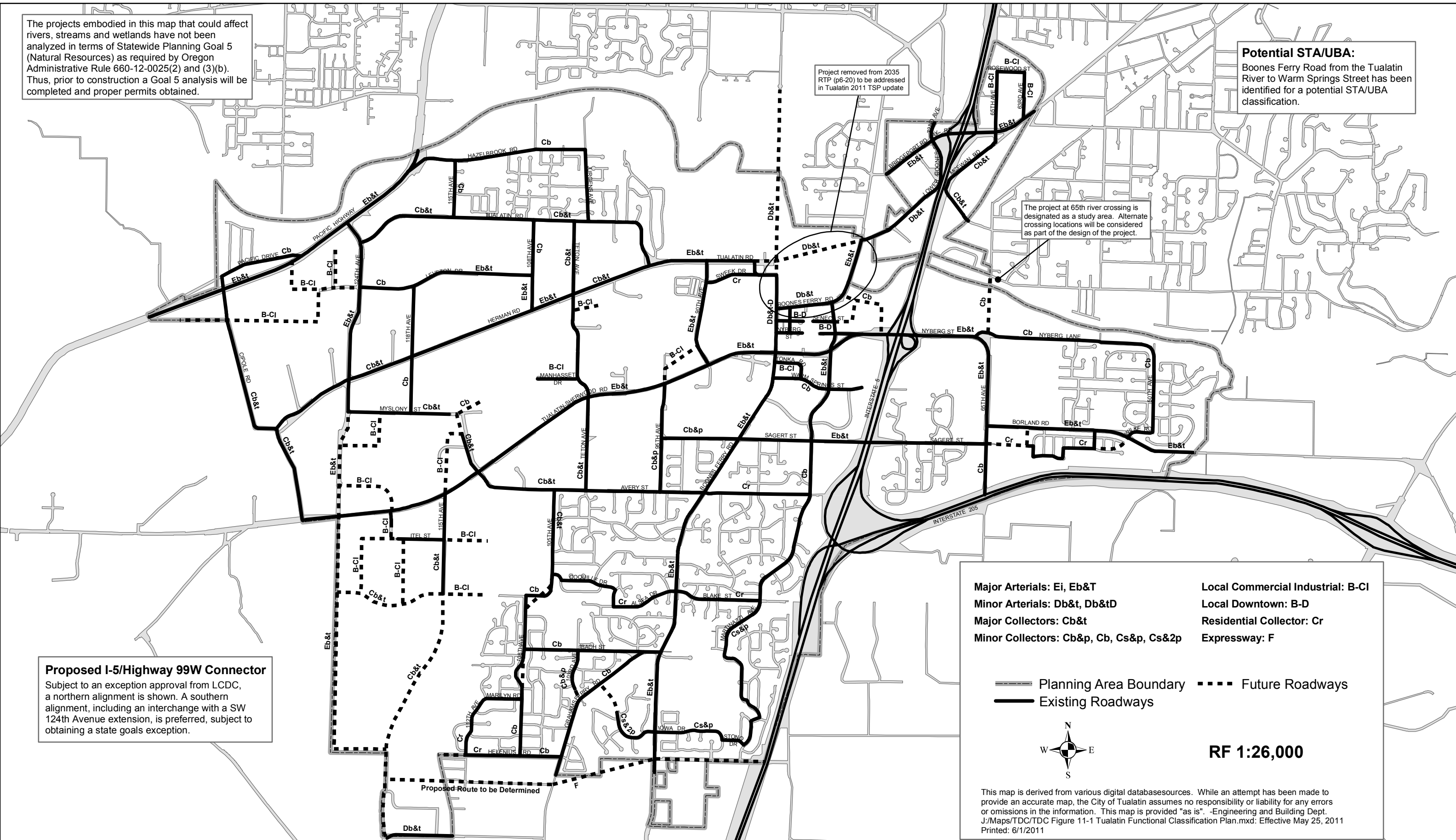

- | | |
|---|-----------------------------------|
| Major Arterials: Ei, Eb&T | Local Commercial Industrial: B-CI |
| Minor Arterials: Db&t, Db&tD | Local Downtown: B-D |
| Major Collectors: Cb&t | Residential Collector: Cr |
| Minor Collectors: Cb&p, Cb, Cs&p, Cs&2p | Expressway: F |

- Planning Area Boundary
- Existing Roadways
- - - Future Roadways

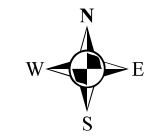



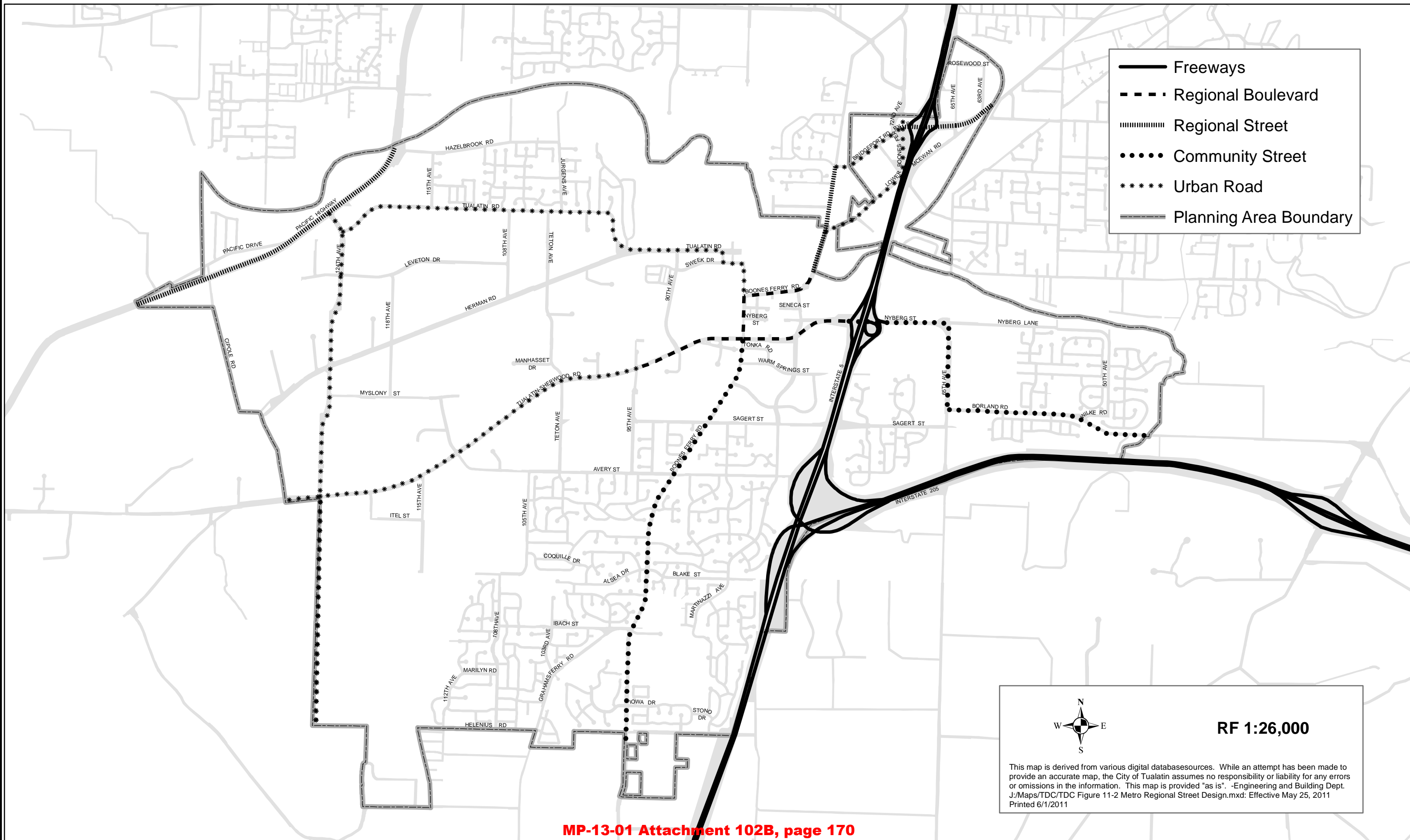

RF 1:26,000

This map is derived from various digital databasesources. While an attempt has been made to provide an accurate map, the City of Tualatin assumes no responsibility or liability for any errors or omissions in the information. This map is provided "as is". -Engineering and Building Dept. J:\Maps\TDC\TDC Figure 11-1 Tualatin Functional Classification Plan.mxd: Effective May 25, 2011 Printed: 6/1/2011

Figure 11-2: Metro Regional Street Design System



	Freeways
	Regional Boulevard
	Regional Street
	Community Street
	Urban Road
	Planning Area Boundary



N
E
S
W

RF 1:26,000

This map is derived from various digital databasesources. While an attempt has been made to provide an accurate map, the City of Tualatin assumes no responsibility or liability for any errors or omissions in the information. This map is provided "as is". -Engineering and Building Dept. J:/Maps/TDC/TDC Figure 11-2 Metro Regional Street Design.mxd: Effective May 25, 2011 Printed 6/1/2011

Figure 11-4: Tualatin Pedestrian Plan

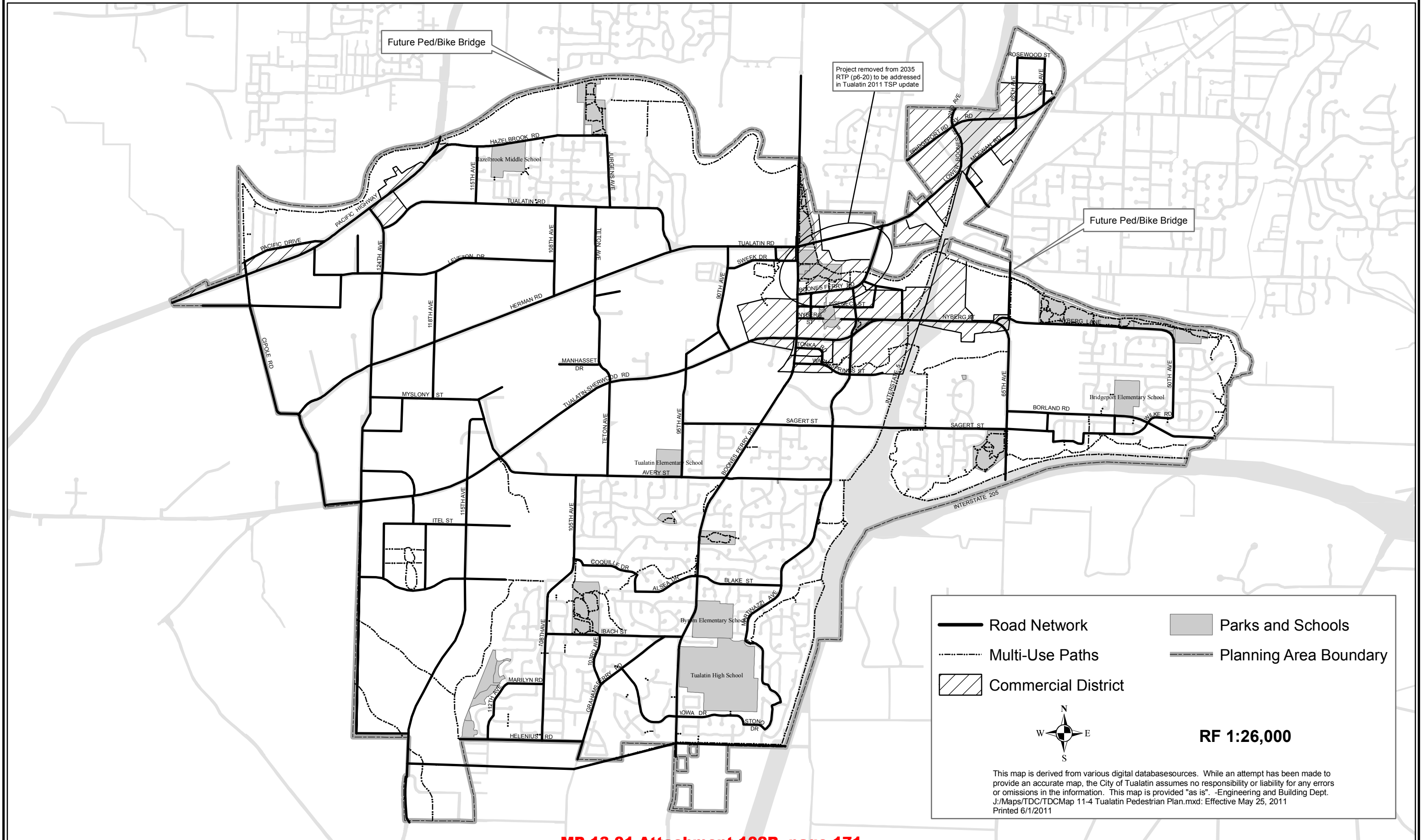
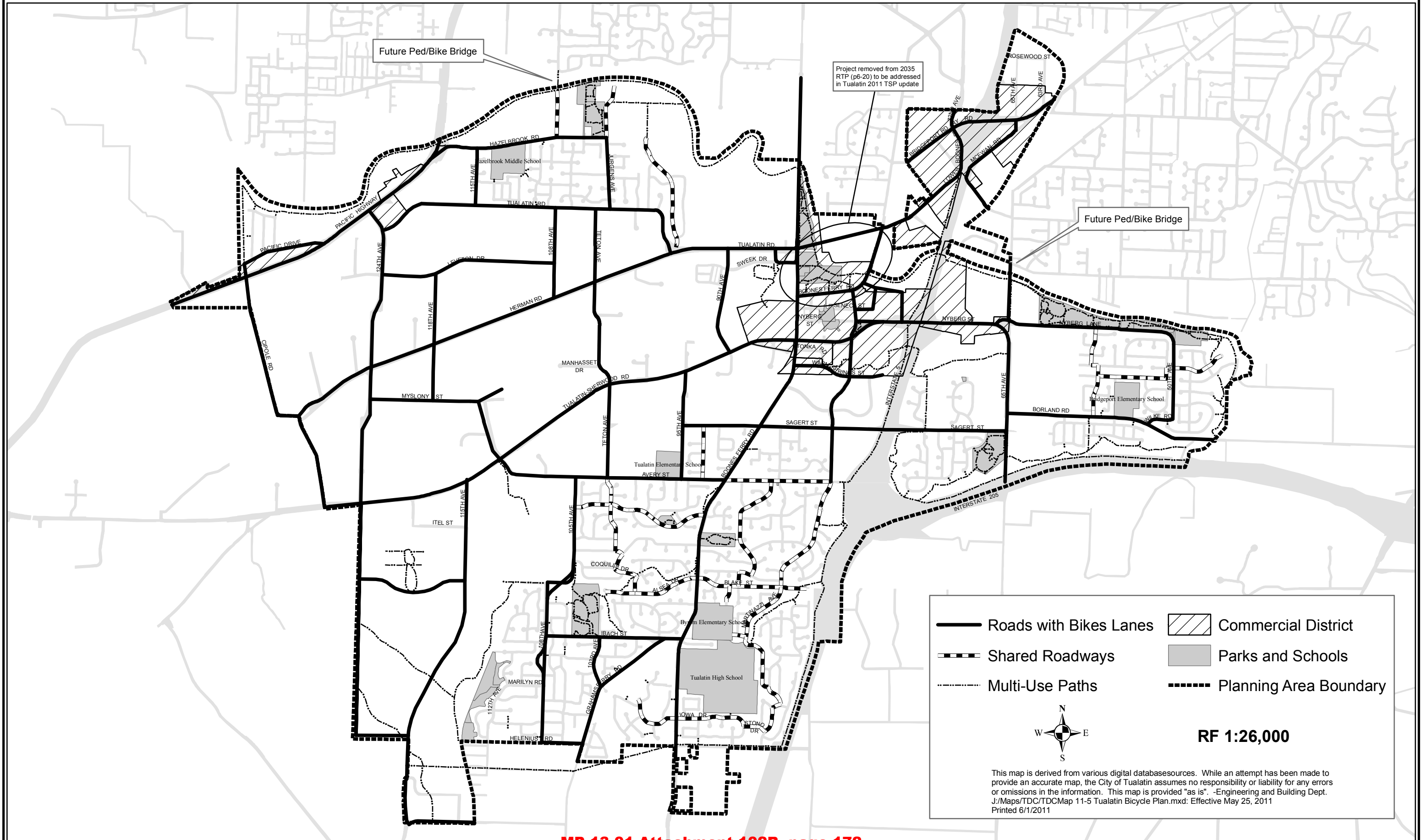









Figure 11-5: Tualatin Bicycle Plan



 Roads with Bikes Lanes	 Commercial District
 Shared Roadways	 Parks and Schools
 Multi-Use Paths	 Planning Area Boundary







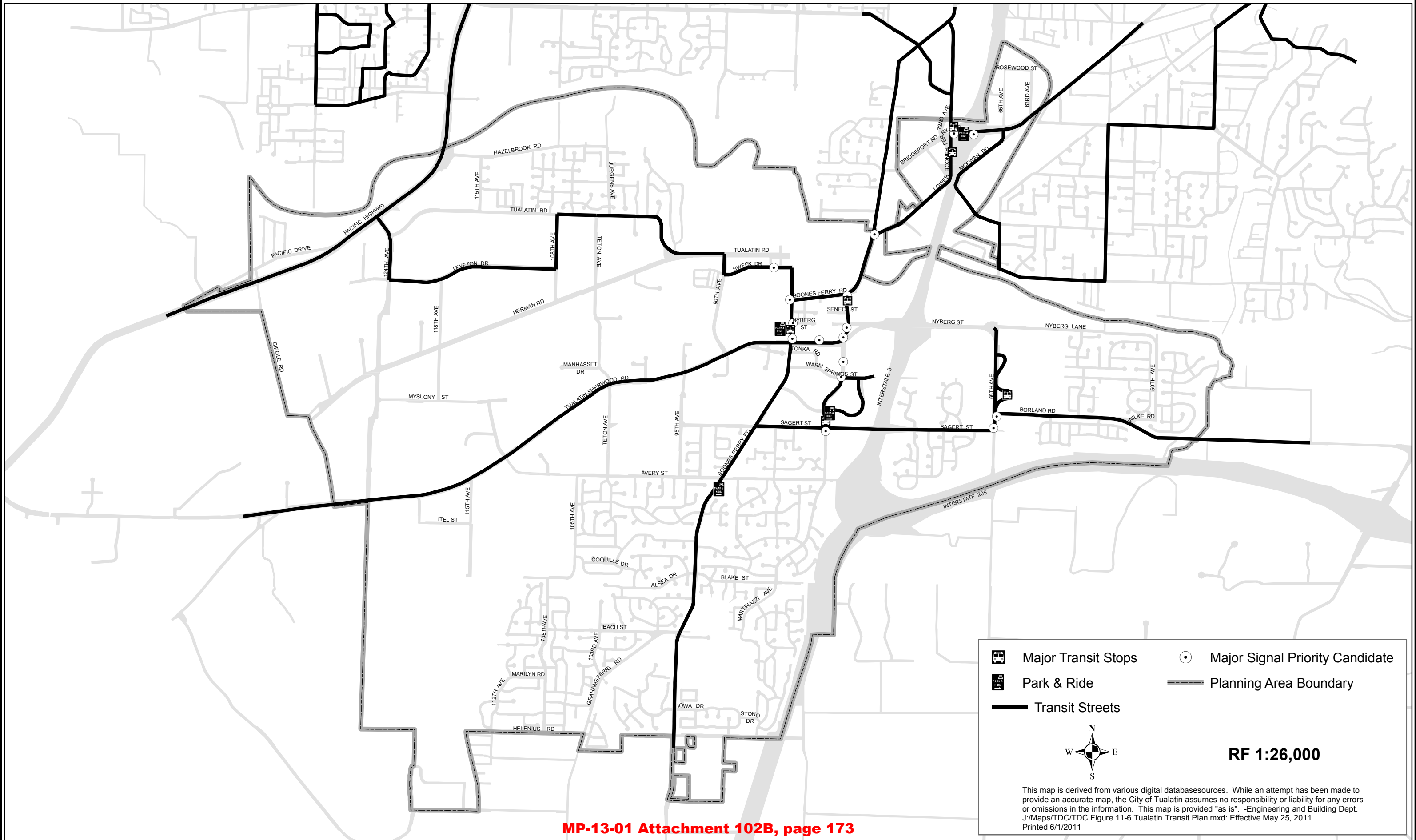

RF 1:26,000

This map is derived from various digital databasesources. While an attempt has been made to provide an accurate map, the City of Tualatin assumes no responsibility or liability for any errors or omissions in the information. This map is provided "as is". -Engineering and Building Dept. J:/Maps/TDC/TDCMap 11-5 Tualatin Bicycle Plan.mxd: Effective May 25, 2011 Printed 6/1/2011

Figure 11-6: Tualatin Transit Plan



 Major Transit Stops	 Major Signal Priority Candidate
 Park & Ride	 Planning Area Boundary
 Transit Streets	



RF 1:26,000

This map is derived from various digital databasesources. While an attempt has been made to provide an accurate map, the City of Tualatin assumes no responsibility or liability for any errors or omissions in the information. This map is provided "as is". -Engineering and Building Dept. J:/Maps/TDC/TDC Figure 11-6 Tualatin Transit Plan.mxd: Effective May 25, 2011 Printed 6/1/2011

Figure 11-7: Tualatin Truck Routes

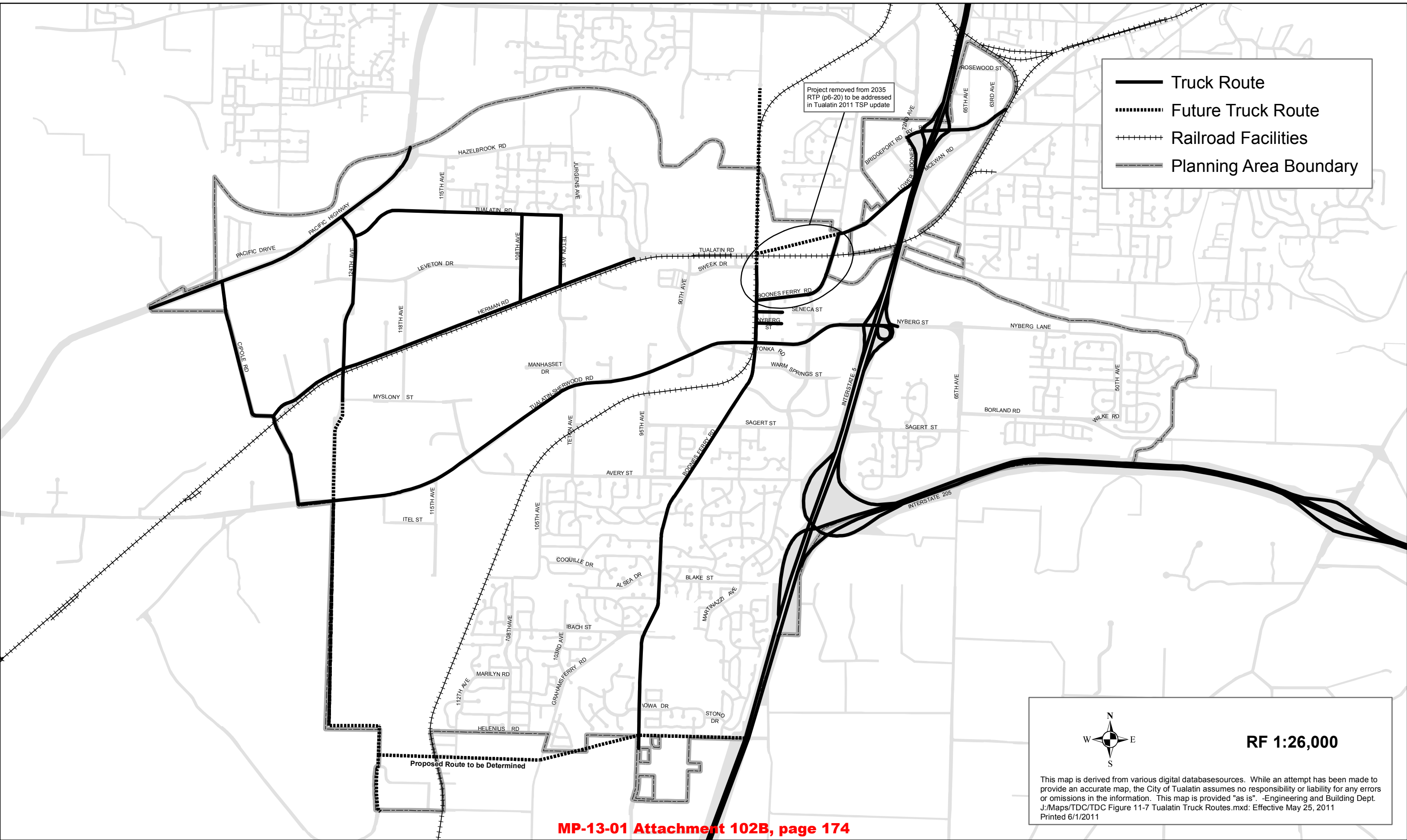

- Truck Route
- Future Truck Route
- + + + + + Railroad Facilities
- - - - - Planning Area Boundary

 **RF 1:26,000**

This map is derived from various digital databasesources. While an attempt has been made to provide an accurate map, the City of Tualatin assumes no responsibility or liability for any errors or omissions in the information. This map is provided "as is". -Engineering and Building Dept. J:/Maps/TDC/TDC Figure 11-7 Tualatin Truck Routes.mxd: Effective May 25, 2011 Printed 6/1/2011

Figure 11-8a: Financially Constrained TSP Projects

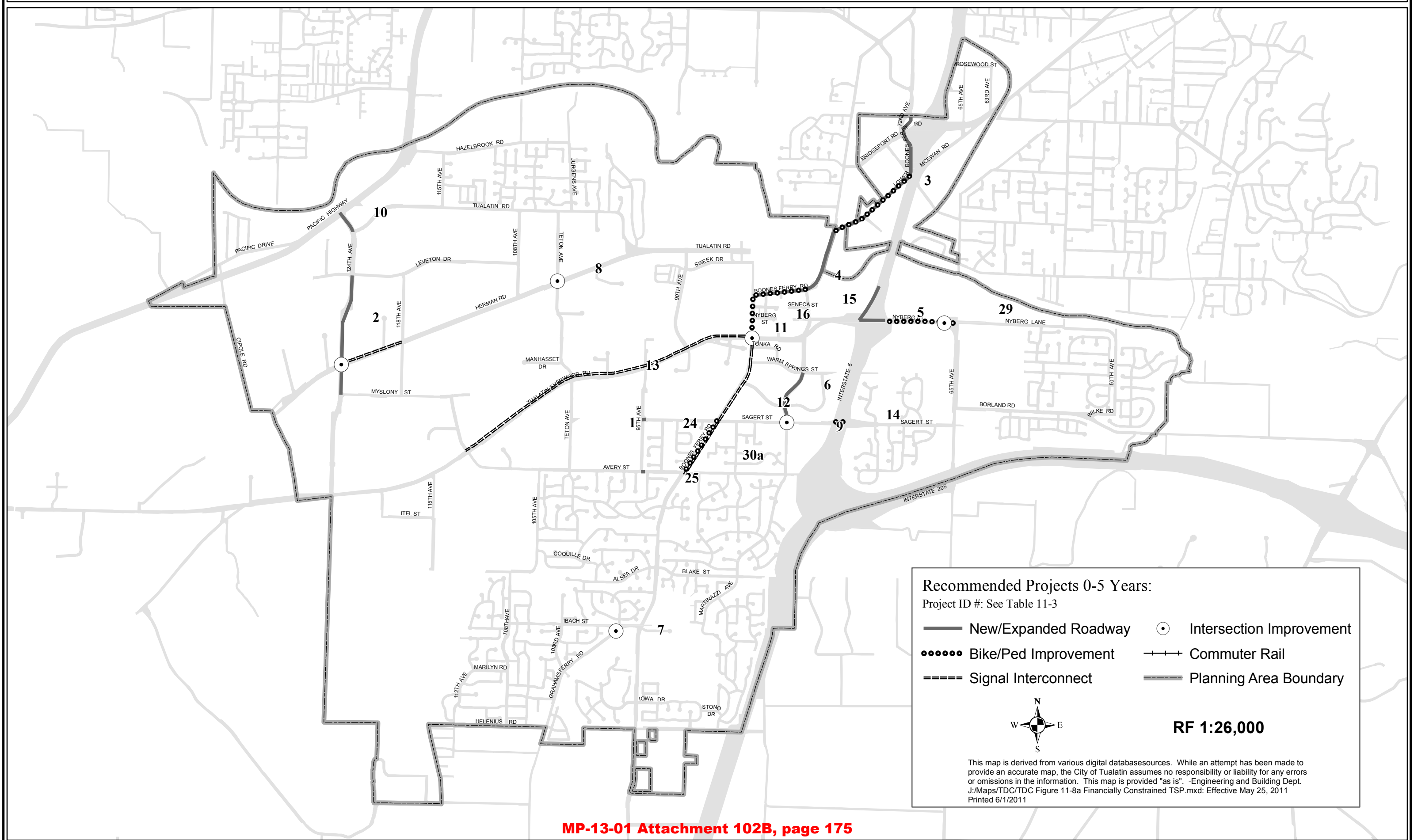

Figure 11-8c: Financially Constrained TSP Projects

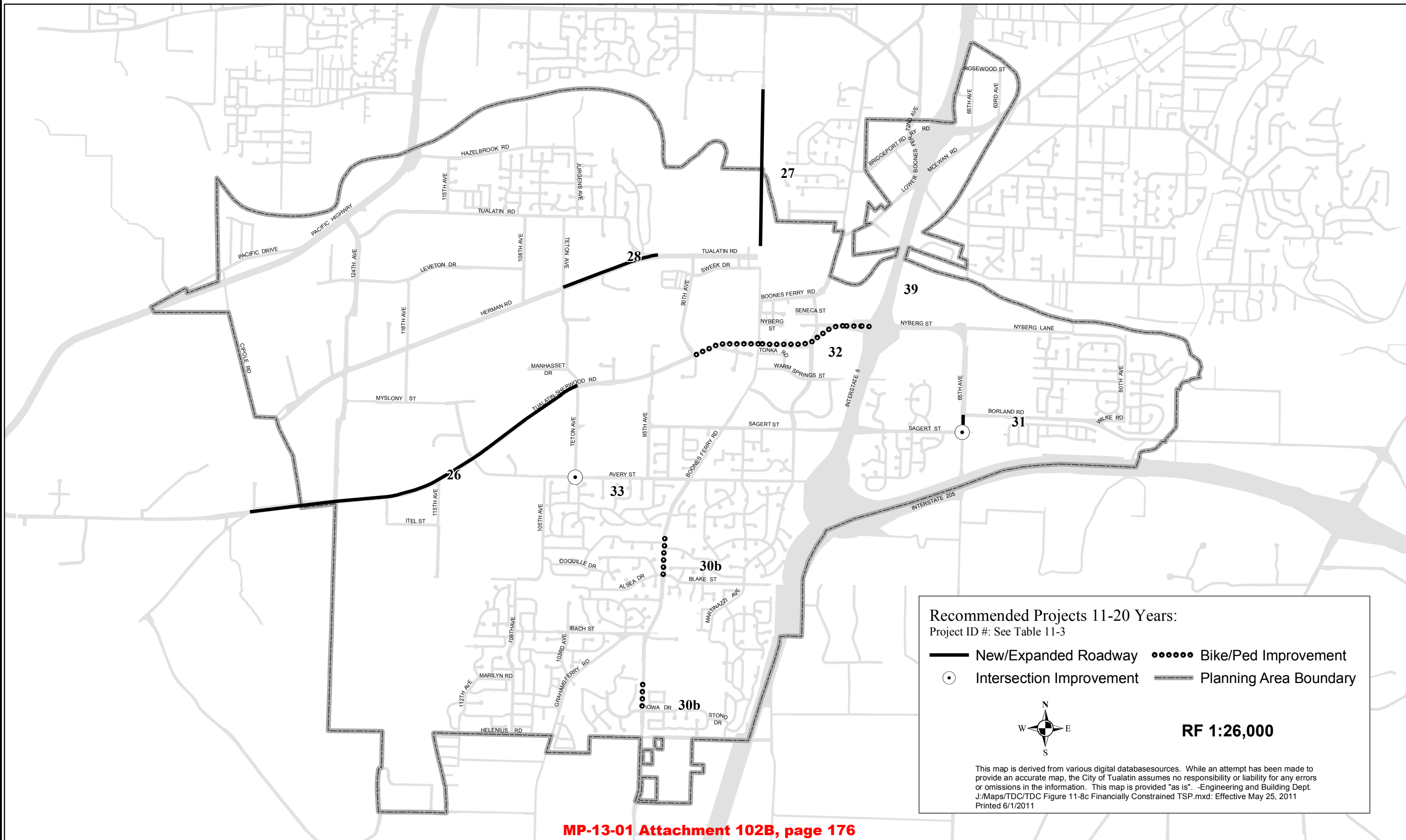
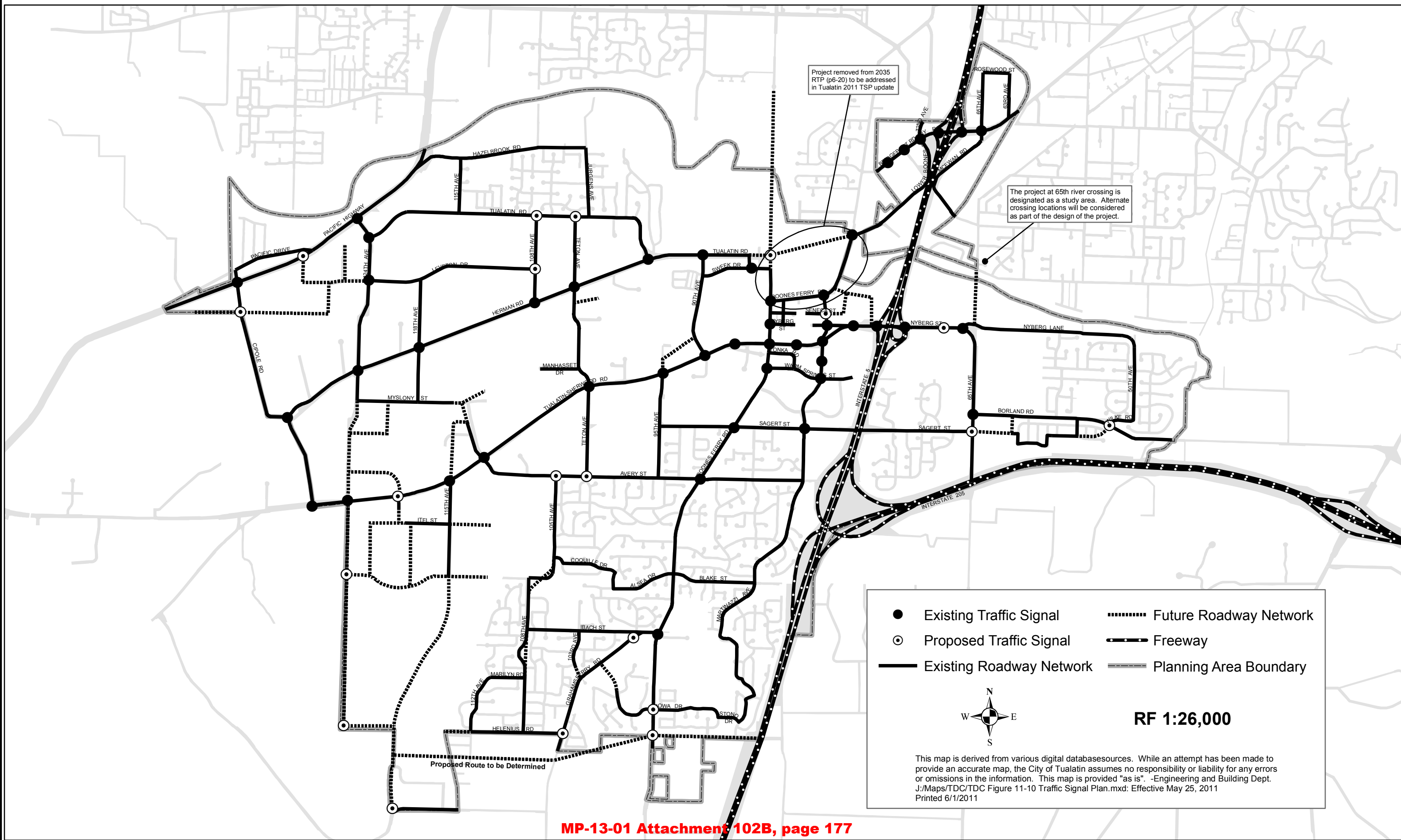

Figure 11-10: Traffic Signal Plan



Tualatin Development Code

TABLE 11-1

TUALATIN FUNCTIONAL CLASSIFICATION DESCRIPTIONS

Functional Classification	Description
Freeway	Primary function is to carry high levels of regional vehicular traffic and public transit at high speeds; full access control with access limited to interchanges and street crossings with grade separations; widely spaced access points; serves motorized vehicle traffic only; contains a median.
Expressway - (F)	Primary function is to carry high levels of regional vehicular traffic and public transit at high speeds, but to a lesser extent than freeways; provides a limited number of grade-separated interchanges (preferred) and at-grade intersections; high access control; serves motorized vehicle traffic only; contains a median.
Major Arterial - (Ei) - (Eb&t)	Primary function is to serve both local and through traffic as it enters and leaves the urban area; connects the minor arterial and collector street system to freeways and expressways; provides access to other cities and communities; serves major traffic movements; access control through medians and/or channelization; restricted on-street parking; sidewalks and bicycle facilities required; may allow a right-turn pocket if warranted; will be used by public transit.
Minor Arterial - (Db&t) - (Db&t – Downtown)	Primary function is to serve local and through traffic between neighborhoods and to community and regional facilities; distributes traffic from major arterials to collectors and local streets, higher degree of access than major arterials; trip lengths, traffic volumes, and speeds are lower than on major arterials; sidewalks and bicycle lanes required; likely to be used by public transit.
Major Collector - (Cb&t)	Primary function is to serve local traffic between neighborhoods and community facilities, principal carrier between arterials and local streets; provides some degree of access to adjacent properties, while maintaining circulation and mobility for all users; carries lower traffic volumes at slower speeds than arterials; typically has two to three lanes; may contain some on-street parking; pedestrian and bicycle facilities are required; may be used by public transit.
Minor Collector - (Cb&p) - (Cs&2p) - (Cs&p) - (Cb)	Primary function is to connect neighborhoods with major collector streets to facilitate movement of local traffic; has slower speeds to ensure community livability and safety for pedestrians and bicyclists; on-street parking is prevalent (except Cb, which must have bicycle lanes on both sides of the street, with no on-street parking); pedestrian and bicycle facilities are re-

(Revised 04/11)

11 - 8

	quired; bicycle facilities may be exclusive or shared roadways depending on traffic volumes, speeds, and extent of bicycle travel; may be used by public transit.
Residential Collector - (Cr)	Provides primary routes into residential neighborhoods; carries higher volumes than local streets, but is not intended to serve through traffic; provides direct access to adjacent land uses; characterized by moderate roadway distances and slow speeds, serves passenger cars, public transit, pedestrians, and bicyclists, but not truck traffic; pedestrian facilities are required.
Local Commercial Industrial - (B-CI)	Primary function is to provide direct truck, public transit, and vehicular access to commercial and industrial land uses; characterized by short to moderate roadway distances and slow speeds; offers a high level of accessibility; pedestrian facilities are required.
Local Street - (B-D) - (B) - (B-Skinny)	Primary function is to provide direct access to adjacent land uses; characterized by short roadway distances, slow speeds, and low volumes; offers a high level of accessibility; serves passenger cars, pedestrians, and bicycles, but not trucks; may be used by public transit, pedestrian facilities are required.
Note: (Xx&xx): Street design standard – See Figures 75-2A through 75-2G	

Tualatin Development Code

TABLE 11-2
STREET FUNCTIONAL CLASSIFICATION SUMMARY

Freeways	Expressway (F)
I-5 – <i>north city limits to south city limits</i> I-205 – <i>from I-5 to east city limits</i>	I-5/Highway 99W connector
Major Arterials (Ei) - applies to the following intersections	
Lower Boones Ferry Road/SW 65 th Avenue/McEwan Road Lower Boones Ferry Road/Bridgeport Road Tualatin-Sherwood Road/Martinazzi Avenue/Nyberg Street	Highway 99W/SW 124 th Avenue Highway 99W/Cipole Road
Major Arterials (Eb&t)	
Highway 99W – <i>north city limits to south city limits</i> Tualatin-Sherwood Road – <i>west city limits to Nyberg St.</i> Nyberg Street – <i>Tualatin-Sherwood Rd. to SW 65th Ave.</i> SW 124 th Avenue – <i>Hwy 99W to Tualatin-Sherwood Rd.</i> Herman Road - <i>Teton to 108th</i> 108th Avenue - <i>Herman to Leveton</i> Leveton Drive - <i>108th to 118th</i> Martinazzi Avenue - <i>Nyberg to Sagert</i> 90th Avenue - <i>Tualatin-Sherwood to Tualatin Rd.</i> 72nd Avenue - <i>Bridgeport to north City limits</i>	Bridgeport Road - <i>City limits to Lower Boones Ferry Road</i> Boones Ferry Road – <i>T-S Road to south city limits</i> Boones Ferry Road - <i>Martinazzi Avenue to Lower Boones Ferry Rd.</i> Lower Boones Ferry Road – <i>Bridgeport Road to east city limits</i> Borland Road – <i>SW 65th Avenue to east city limits</i> Sagert Street – <i>Martinazzi to SW 65th Avenue</i> SW 65 th Avenue – <i>Sagert Street to Nyberg</i> Tualatin Road - <i>Herman to Hall Blvd extension</i>
Minor Arterials (Db&t, Db&t – Downtown)	
Boones Ferry Rd – <i>Tualatin-Sherwood Rd to Martinazzi Ave</i> Martinazzi Avenue – <i>Nyberg to Boones Ferry Rd</i> Tualatin Road – <i>Boones Ferry Rd to Hall Blvd extension</i> Lower Boones Ferry Rd – <i>Boones Ferry Rd to Bridgeport Rd</i>	Tonquin Road – <i>Portland & Western Railroad west to the planning area boundary (i9ntersecting with SW 115th Avenue and SW 124th Avenue)</i> Hall Boulevard – <i>Tualatin Road to north city limits</i> <i>Tualatin Road Extension - Chinook to Lower Boones Ferry</i>
Major Collectors (Cb&t)	
Tualatin Road – <i>SW 124th Avenue to Herman</i>	McEwan Road – <i>East city limits to Lower Boones Ferry Road</i>

Tualatin Development Code

11.620

<p>Cipole Road – <i>Pacific Drive to Tualatin-Sherwood Road</i> Herman Road – <i>Cipole Road to 108th and Teton to Tualatin Road</i> Teton Road – <i>Tualatin Road to Avery Street</i> Myslony Street – <i>SW 124th Avenue to SW 112th Avenue</i> SW 112th Avenue – <i>Myslony Street to Tualatin-Sherwood Road</i> SW 115th Avenue – <i>Tualatin-Sherwood Road to Tonquin Road intersecting with Blake Street</i> Blake Street – <i>SW 124th Avenue to SW 115th Avenue</i> Unnamed east/west roadway south of Blake Street – <i>SW 124th Avenue to SW 115th Drive</i></p>	<p>Avery Street – <i>Tualatin-Sherwood Road to Boones Ferry Road</i> SW 105th Avenue – <i>Avery to Blake Street curves</i> Tualatin Road - <i>Chinook to Tualatin Road over the tracks</i> Sagert St - <i>Boones Ferry Road to Martinazzi</i></p>
<p>Minor Collectors (Cb&p, Cs&2p, Cs&p, Cb)</p>	
<p>Leveton Drive – <i>SW 124th Avenue to SW 118th Avenue</i> SW 108th Avenue – <i>Tualatin Road to Leveton Dr.</i> SW 118th Avenue – <i>Leveton Drive to Myslony Street</i> Hazelbrook Road – <i>Highway 99W to Jurgens Avenue</i> SW 115th Avenue – <i>Hazelbrook Road to Tualatin Road</i> Jurgens Avenue – <i>Hazelbrook Road to Tualatin Road</i> SW 108th Avenue – <i>Blake Street curves to Helenius Road</i> Ibach Street – <i>SW 108th Avenue to Grahams Ferry Road</i> Grahams Ferry Road – <i>Boones Ferry to south City limits</i> Pacific Drive – <i>Cipole Road to Highway 99W</i> Helenius Road – <i>SW 108th Avenue to Grahams Ferry Road</i> SW 103rd Avenue – <i>Ibach Street to Grahams Ferry Road</i> 65th Avenue - <i>Nyberg St north to river</i></p>	<p>Iowa Drive – <i>Grahams Ferry Road to Stono Drive</i> Martinazzi Avenue – <i>Maricopa Drive to Sagert St</i></p> <p>Warm Springs Street – <i>Boones Ferry Road to Martinazzi Avenue</i> SW 65th Avenue – <i>Sagert Street to south city limits</i> Nyberg Lane – <i>SW 65th Avenue to SW 50th Avenue</i> SW 50th Avenue – <i>Nyberg Lane to Wilke Road</i> Wilke Road – <i>Borland Road to SW 50th Avenue</i> Sagert Street – <i>Boones Ferry Road to SW 95th Avenue</i> Stono Drive – <i>Iowa Drive to Vermillion Drive</i> Vermillion Drive – <i>Stono Drive to Maricopa Drive</i> Maricopa Drive – <i>Vermillion Drive to Martinazzi Avenue</i> Loop Road - <i>Nyberg Road to Martinazzi Avenue</i> 95th Avenue - <i>Tualatin-Sherwood Road to Avery Street</i></p>

Tualatin Development Code

Residential Collector (Cr)	
<p>Avery Street – Boones Ferry Road to Martinazzi Avenue Blake Street – Martinazzi Avenue to Boones Ferry Road Marilyn Road – SW 112th Avenue to SW 108h Avenue unnamed east/west roadway – SW 108th Avenue to SW 112th Avenue Alsea Drive – SW 99th Avenue to Boones Ferry Road SW 99th Avenue – Paulina Drive to Alsea Drive SW 112th Avenue – Marilyn Road to Helenius Road</p>	<p>Sagert Street – east of SW 65th Avenue Sweek Drive – Tualatin Road to SW 90th Avenue Helenius Road – SW 108th Avenue to SW 112th Avenue Paulina Drive – SW 105th Avenue to Coquille Drive (west) Paulina Drive – Coquille Drive (east) to SW 99th Avenue Coquille Drive – Paulina Drive (west) to Paulina Drive (east)</p>
Local Commercial Industrial (B-CI)	
<p>Tonka Road – Boones Ferry Road to Warm Springs Street SW 65th Avenue – Lower Boones Ferry Road to Rosewood Street Rosewood Street – SW 65th Avenue to SW 63rd Avenue SW 63rd Avenue – Rosewood Street to Lower Boones Ferry Road Leveton Drive – SW 124th Avenue to SW 130th Avenue SW 130th Avenue – Leveton Drive to Highway 99W SW 125th Place – north of Leveton Drive SW 128th Avenue – Leveton Drive to Cummins Street Cummins Street – SW 128th Avenue to Cipole Road Spokane Court – east of Teton Avenue 115th Avenue – Tualatin-Sherwood Rd to 112th SW 117th Avenue – Itel Street to Blake Street SW 122nd Avenue – Itel Street to Blake Street</p>	<p>Manhasset Drive – west of Teton Avenue unnamed roadway – SW 124th Avenue to Myslony Street (could potentially become a private roadway) unnamed roadway – SW 124th Avenue to Tualatin-Sherwood Road (could potentially become a private roadway) SW 120th Avenue – south of Tualatin-Sherwood Road to Blake Street ext. SW 115th Avenue – Tualatin-Sherwood Road to McCamant Road Blake Street – west of SW 105th Avenue to SW 120th Avenue extension unnamed east/west roadway – east of SW 120th Avenue past SW 115th Ave unnamed east/west roadway - 120th Ave. to Tri-County Industrial Park unnamed east/west roadway - east of 112th Avenue unnamed roadway west of Cipole across from Cummins Street (could potentially become a private roadway)</p>
Local Street Downtown (B-D)	
<p>Seneca Street – west of Martinazzi Avenue Seneca Street – east of Boones Ferry</p>	

Tualatin Development Code

11.620

<p><i>Road</i> Nyberg Street – west of Martinazzi Avenue Nyberg Street – east of Boones Ferry Road <i>Road</i> SW 84th Avenue – Boones Ferry Road to Nyberg Street</p>	
---	--

Tualatin Development Code

TABLE 11-3
TRANSPORTATION IMPROVEMENT PROGRAM SUMMARY

Figure 11-8 id #	Project Description	Modes Served	Purpose	Cost	Funding Source(s)
0-5 Years					
1	Wilsonville-Beaverton Commuter Rail capital costs to start up service	Transit	mode choice, connectivity	\$75,000,000*	MSTIP, STIP
2	124th Avenue new street, Leveton to Myslony, signal at Herman	auto, ped, bike, rail	connectivity, safety	\$6,500,000*	LTIP
3	Lower Boones Ferry Road center turn lane, bike lanes, sidewalks, Bridgeport to Boones Ferry	auto, ped, bike, transit	safety, connectivity, capacity	\$5,800,000*	MSTIP
4	Boones Ferry Road center turn lane, bike lanes, sidewalk, Martinazzi to Tualatin-Sherwood	auto, ped, bike, transit	safety, connectivity, capacity	\$3,500,000*	CURP
5	Nyberg/I-5 interchange (#289) southbound turn lanes, widen bridge	auto, ped, bike	capacity	\$4,000,000*	CURP, STIP, SDC
6	Martinazzi Avenue new southbound lane, Warm Springs to Sagert	auto, ped, transit	capacity, safety	\$300,000*	SDC
7	Grahams Ferry Road/Ibach Street realign, signalize intersection	auto, ped, bike	safety, capacity	\$700,000*	SDC
8	Herman Road/Teton Avenue signalize intersection, railroad interconnect	auto, ped, bike, rail	capacity, safety	\$425,000*	SDC
9	Sagert Street/Martinazzi Avenue signalize intersection	auto, ped, transit	capacity	\$600,000*	SDC
10	124th Avenue additional travel lane at Highway 99W	auto, transit	capacity	\$270,000*	LTIP

Tualatin Development Code

11.730

Figure 11-8 id #	Project Description	Modes Served	Purpose	Cost	Funding Source(s)
11	Tualatin-Sherwood Road/Boones Ferry Road second westbound left-turn lane	auto, transit	capacity	\$700,000*	SDC
12	Boones Ferry Road interconnect signals south of Tualatin-Sherwood	auto, transit	progress through traffic	\$50,000*	SDC (needs to be added)
13	Tualatin-Sherwood Road interconnect signals west of Boones Ferry	auto, transit	progress through traffic	\$50,000*	SDC (needs to be added)
14	Sagert Street construct sidewalks on I-5 overpass	ped	Pedestrian safety, connectivity	\$13,500*	SDC (needs to be added)
15	Boones Ferry Road, Martinazzi Avenue driveway restrictions	auto, transit	safety, capacity	\$7,500*	SDC
16	Tualatin Town Center Refinement Plan to address RTP Area of Special Concern	Auto, transit, ped, bike	planning	\$20,000*	City
24	Sagert Street connect to 95th Place	auto, ped, bike	connectivity	\$75,000*	SDC
25	95th Place connect to Avery Street	auto, ped, bike	connectivity	\$250,000*	SDC
29	Nyberg Street/65th Avenue/Nyberg Lane signalize intersection or construct roundabout, sidewalks on Nyberg	auto, ped, bike	capacity, safety	\$650,000*	SDC
30a	Boones Ferry Road complete sidewalks, T-S Road to Avery Street	ped	safety, connectivity	\$250,000*	SDC (needs to be added)
6-10 Years					
17	124th Avenue new street, Myslony to T-S Road, signal at T-S Road	auto, ped, bike	connectivity	\$5,150,000*	LTIP
18	Herman Road reconstruct, 108th to 118th	auto, ped, bike, freight movement	modernization	\$2,720,290*	LTIP

Tualatin Development Code

Figure 11-8 id #	Project Description	Modes Served	Purpose	Cost	Funding Source(s)
35	Herman Road/108th Avenue signalize, railroad inter-connect	auto, ped, bike, rail	capacity, safety	\$200,000*	LTIP
36	Herman Road/118th Avenue signalize, railroad inter-connect	auto, ped, bike, rail	capacity, safety	\$200,000*	LTIP
19	Herman Road reconstruct, Teton to 108th	auto, ped, bike, freight movement	modernization	\$920,000*	SDC
20	Leveton Drive, 130th Avenue new streets	auto, ped, bike	connectivity, facilitate development	\$1,961,400*	LTIP & Development
21	SW 128th Avenue, Cummins Drive new streets	auto, ped, bike	connectivity, facilitate development	\$3,001,750*	LTIP & Development
22	105th Avenue-Blake Street-108th Avenue realign curves	auto, ped, bike	safety	\$860,000*	SDC
11-20 Years					
26	Tualatin-Sherwood Road widen to five lanes, Teton to Highway 99W	auto, transit	capacity, freight movement	\$25,000,000*	MSTIP
27	Hall Boulevard extend across Tualatin River	auto, ped, bike, transit	connectivity, recreation, capacity	\$25,000,000*	MSTIP, STIP, CURP, cities
Figure 11-8 id #	Project Description	Modes Served	Purpose	Cost	Funding Source(s)
28	Herman Road reconstruct, Tualatin Road to Teton	auto, ped, bike	modernization	\$1,700,000*	SDC
30b	Boones Ferry Road complete sidewalks, Avery St to Tualatin High School	ped	safety, connectivity	\$250,000*	SDC (needs to be added)

Tualatin Development Code

11.730

31	Sagert Street/65th Avenue turn lane, signalize, interconnect with Borland Road/SW 65th Avenue intersection	auto, ped, transit	capacity	\$400,000*	SDC
Figure 11-8 id #	Project Description	Modes Served	Purpose	Cost	Funding Source(s)
32	Tualatin-Sherwood Road bike lanes, 90th-Nyberg	bike	connectivity	\$330,000*	SDC (needs to be added)
33	Avery Street/Teton Avenue signalize intersection	auto, ped, bike	capacity	\$200,000*	SDC (needs to be added)
43	SW 124 th Avenue new street, Tualatin-Sherwood Road to Tonquin Road and/or a future I5/99W Connector, traffic signals at Blake Street and unnamed east/west collector	Auto, ped, bike, freight movement	connectivity, reduce truck delays	\$85,745,000	
Development-Related					
40	Bridgeport Road widen to 5+ lanes, west city limits to Lower Boones Ferry Road	auto, ped, bike	capacity, connectivity, safety, facilitate development	TBD	Development
23	SW 125th Place new street	auto, ped, bike	connectivity, facilitate development	\$360,000*	Development
34	East West Street in southwest residential Tualatin new street, 108 th to 112 th Avenues	auto, ped, bike	connectivity, facilitate development	\$1,100,000*	Development
37	Tualatin Road/108th Avenue signalize	auto, ped, bike, transit	capacity, safety	\$200,000*	Development
38	Cummins Drive/Cipole Road/unnamed street west of Cipole signalize	auto, ped, bike	capacity	\$200,000*	Development

Tualatin Development Code

41	Cipole Road widening from Highway 99W to Cummins Drive modified signal phasing at Highway 99W intersection	auto, ped, bike	capacity, facilitate development	\$1,195,000**	Development
42	SW Herman Road/SW Cipole Road realign, signalize intersection, railroad interconnect	auto, ped, bike	capacity, safety	\$1,800,000**	Development, LID
44	SW 115 th Avenue new or widened street, Blake Street to Tonquin Road	auto, ped, bike	connectivity, facilitate development	\$11,162,000	Development
45	Blake Street new street, west of the railroad to SW 124 th Avenue	auto, ped, bike	connectivity, facilitate development	\$15,846,088	Development
46	Tonquin Road new or widened street, bridge over the railroad crossing and a signal at SW 115 th Avenue	auto, ped, bike	connectivity, facilitate development	\$15,985,600	Development
47	Unnamed east-west collector new street between SW 115 th Avenue and SW 124 th Avenue	auto, ped, bike	connectivity, facilitate development	\$2,258,244	Development
48	Istel Street and SW 122 nd Avenue new or widened street between SW 120 th Avenue and Blake Street	auto, ped, bike	connectivity, facilitate development	\$3,190,000	Development
49	SW 117 th Avenue new street between Istel Street and Blake Street	auto, ped, bike	connectivity, facilitate development	\$1,540,000	Development

*2001 dollars; costs are not adjusted for inflation

** 2005 dollars, costs are not adjusted for inflation.

MSTIP: Washington County Major Streets Transportation Improvement Program, STIP: Oregon Statewide Transportation Improvement Program, CURP: Central Urban Renewal Plan, LTIP: Leveton Tax Increment Plan, TGM: Oregon Transportation Growth Management Program, SDC: Systems Development Charge, TBD: to be determined.

The projects listed in each time period are for planning purposes only and may change by City Council direction to address development, funding opportunities, or community need.

Tualatin Development Code

TABLE 11-4
PROJECTS UNFUNDED OR REQUIRING NEW FUNDING SOURCES

Project Description	Modes Served	Purpose	Cost
Recreation SDC or Bond			
SW 108th Avenue ped/bike bridge	ped, bike	recreation, connectivity	\$450,000*
Tualatin River pathway	ped, bike	recreation	\$2,500,000*
SW 65th Avenue ped/bike bridge	ped, bike	recreation, connectivity	\$450,000*
Nyberg Creek pathway	ped, bike	recreation, connectivity	\$170,000*
Pedestrian trail system completion (6 projects)	ped	recreation	\$625,000*
Tonquin Trail (SW Tualatin Concept Area)	ped, bike	recreation	\$880,000
Unfunded Industrial Area Projects			
Myslony Street (112th Avenue) extend to Tualatin-Sherwood Road	auto, ped, bike	connectivity	\$1,880,000*
Cipole Road widen to three lanes, Cummins Drive to T-S	auto, ped, bike, freight movement	capacity, modernization	\$5,500,000*
Herman Road reconstruct, Cipole Road to SW 124th Avenue	auto, ped, bike, freight movement	modernization	\$920,000*
Herman Road reconstruct, 118th Avenue to SW 124th Avenue	auto, ped, bike, freight movement	modernization	\$1,250,000*
Leveton Drive widen to five lanes, SW 108th to SW 118 th	auto, ped, bike, freight movement	capacity	\$1,000,000*
SW 108th Avenue widen to five lanes, Leveton to Herman	auto, ped, bike, freight movement	capacity	\$500,000*
Herman Road widen to five lanes, SW 108th to Teton	auto, ped, bike, freight movement	capacity	\$900,000*
Unnamed roadway extending west of Cipole Road/Cummins Drive intersection	auto, ped, bike, freight movement	capacity	\$840,000**
STIP/Federal Earmark			
I-5/Highway 99W Connector	auto, freight movement	capacity, reduce auto & truck delays	\$250,000,000*
I-205 widen to six lanes, I-5 to Stafford Road	auto, freight movement	capacity, safety	\$6,100,000*
Lower Boones Ferry Road interchange (#290)	auto, transit	capacity	TBD

Tualatin Development Code

11.730

Project Description	Modes Served	Purpose	Cost
reconstruct with loop ramps			
LID			
SW 93rd Avenue Complete to City standards	auto, ped, bike	modernization	\$150,000*
Unfunded, Other Priority Projects			
Boones Ferry Road/Blake Street Construct turn lanes, signalize	auto, ped, bike	safety, capacity	\$1,200,000*
Teton Avenue bike lanes, Herman Road to T-S	Bike	connectivity, safety	\$750,000*
McEwan Road widen to three lanes, Lower Boones Ferry to city limits	auto, ped, bike	capacity, modernization	\$2,300,000*
Avery Street/SW 105th Avenue Signalize	auto	capacity	\$150,000*
Unfunded, Other Desirable Projects			
Lower Boones Ferry Road extend across Tualatin River	auto, ped, bike	capacity, connectiv- ity	\$14,000,000* + right-of-way
Boones Ferry Road widen to five lanes, T-S to Ibach	auto, ped, bike, transit	capacity	\$3,000,000*
Nyberg Street bike lanes, T-S to SW 65th Avenue	bike	connectivity	\$850,000*
Borland Road bike lanes	bike	connectivity	\$1,500,000*
SW 65th Avenue*** extend across Tualatin River	auto, ped, bike	capacity, connectiv- ity	\$10,000,000*
SW 65th Avenue bike lanes, Nyberg to Borland	bike	connectivity	\$700,000*
SW 95th Avenue extend to SW 90th Avenue	auto, ped, bike	connectivity	\$500,000*
Highway 99W sidewalks, north city limits to south city limits	ped	connectivity	\$1,100,000*
SW 105th Avenue sidewalks, west side	ped	connectivity	\$84,000*
Tualatin Road/Teton Avenue Signalize	auto	capacity	\$150,000*
Leveton Drive/SW 108th Avenue Signalize	auto	capacity	\$150,000*
Borland Road/Wilke Road Signalize	auto	capacity	\$150,000*
Grahams Ferry Road/Helenius Road Signalize	auto	capacity	\$150,000*
Highway 99W/SW 130th Avenue Signalize	Auto	capacity	\$150,000*
Central design district pedestrian street	pedestrian	safety	\$2,600,000*

Tualatin Development Code

Project Description	Modes Served	Purpose	Cost
enhancements			
Highway 99W widen to six lanes, Cipole Rd to the Tualatin River	auto	capacity	\$4,000,000*
Tualatin Road widen to five lanes, Herman to Boones Ferry	auto	capacity	\$2,500,000*
SW 65th Avenue widen to five lanes, Sagert to Nyberg	auto	capacity	\$2,300,000*
Borland Road widen to five lanes	auto	capacity	\$4,300,000*
Nyberg Road widen to seven lanes, Martinazzi to I-5	auto	capacity	\$700,000*
95th Avenue bike lanes, Avery to Tualatin-Sherwood Rd.	bike	connectivity	\$1,000,000*
Sagert Street widen to five lanes, Martinazzi to SW 65th	auto	capacity	\$2,300,000*+ bridge widening
SW 90th Avenue widen to five lanes, Tualatin to Tualatin-Sherwood	auto	capacity	\$1,200,000*
All segments of streets designated E, D, C and B-CI in Figure 11-1 that are not specifically listed above.	auto, ped, bike	capacity, safety, connectivity, modernization	TBD
Boones Ferry Road widen to four lanes with turn lane or medians of varying widths from Lower Boones to Martinazzi	Auto, ped, bike, transit	Safety, connectivity, capacity	\$3,500,000*
Loop Road extend Seneca Street east of Martinazzi then north between the City offices and the old Safeway, then east behind K-Mart and south on the east side of K-Mart. A connection to Boones Ferry Road may be appropriate on the north side of the City offices.	Auto, ped, bike	Capacity, connectivity	\$2,500,000*
<p>*2001 dollars; costs are not adjusted for inflation ** 2005 dollars, costs are not adjusted for inflation *** The project at 65th river crossing is designated as a study area. Alternate crossing locations will be considered as part of the design of this project. MSTIP: Washington County Major Streets Transportation Improvement Program, STIP: Oregon Statewide Transportation Improvement Program, CURP: Central Urban Renewal Plan, LTIP: Leveton Tax Increment Plan, TGM: Oregon Transportation Growth Management Program, SDC: Systems Development Charge, TBD: to be determined</p>			

Tualatin Development Code

11.730

[Ord. 1103-02, 03/25/02; Ord. 1191-05, 6/27/05; Ord. 1213-06, 7/10/06; Ord. 1321-11 §18, 4/25/11]

NW1/4 SECTION 24 T2S RIW W.M.

WASHINGTON COUNTY OREGON

SCALE 1"=200'

2S | 24B

CANCELLED TAX LOTS
1003, 1004, 1401, 2101, 1001, 1002,
1005, 100, 101, 102, 200, 300, 400,
401, 401-M1, 402, 500, 600, 700,
701, 800, 900, 1400, 1200, 1600,
1700, 1800,

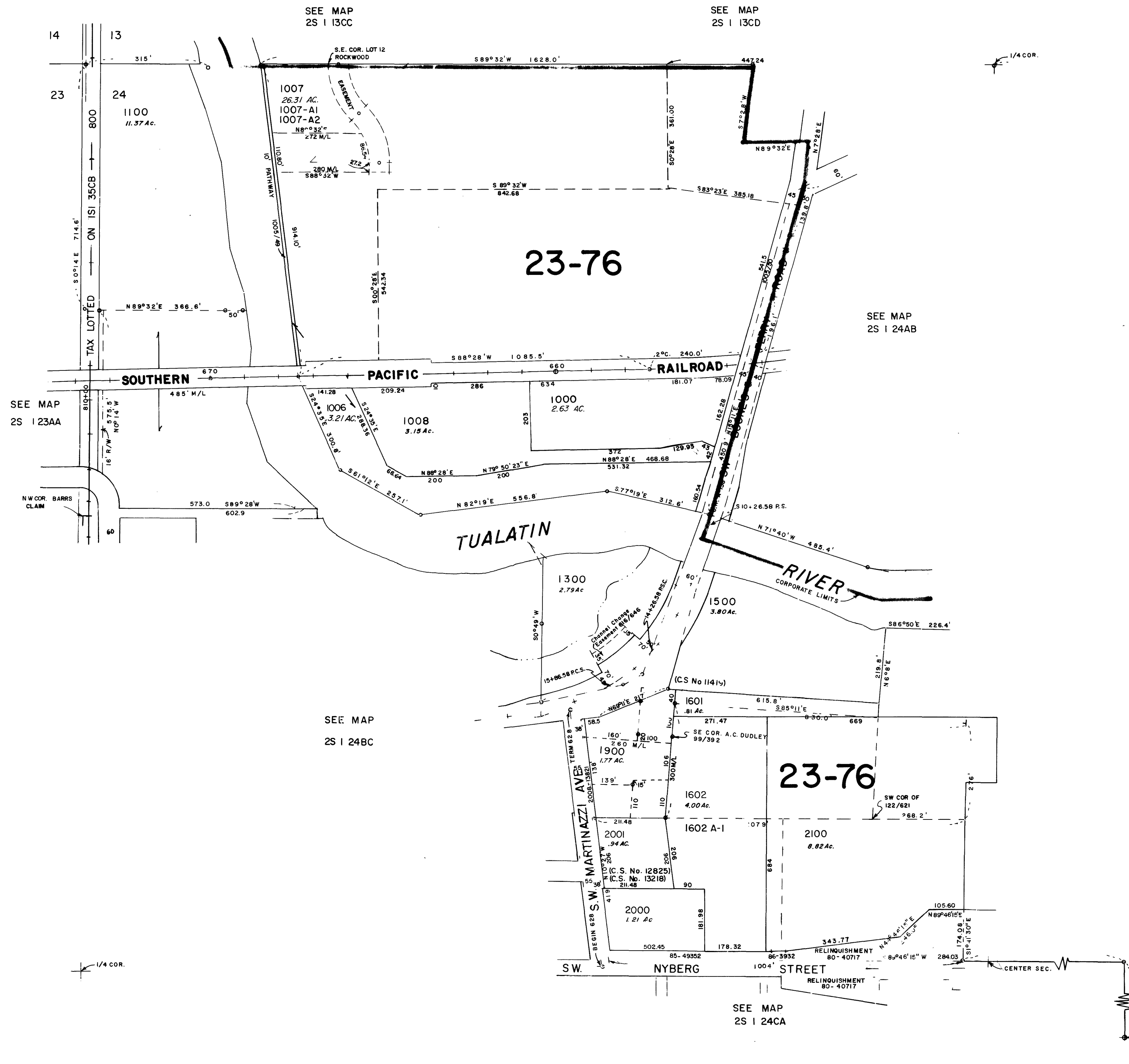

J.S.W. 9/17/59

CANCELLED TAX LOT NUMBERS
2400, 2504, 1301, 701, 800, 100, 101, 102
103, 104, 105, 200, 300, 400, 401, 500, 600
700, 900, 1000, 1100, 1200, 1300, 1400
1500, 1600, 1700, 1800, 1900, 2000, 2100
2200, 2300, 2590, 2500, 2501-A1, 2501,
2505, 2509.

FOR ASSESSMENT PURPOSES ONLY
DO NOT RELY ON FOR ANY OTHER USE

SEE MAP
2S 1 24AA

SEE MAP
2S 1 24AB

SEE MAP
2S 1 24B

SEE MAP
2S 1 24DB

SEE MAP
2S 1 24DA

C O U N T Y

C L A C K A M A S

TUALATIN
2S 1 24A

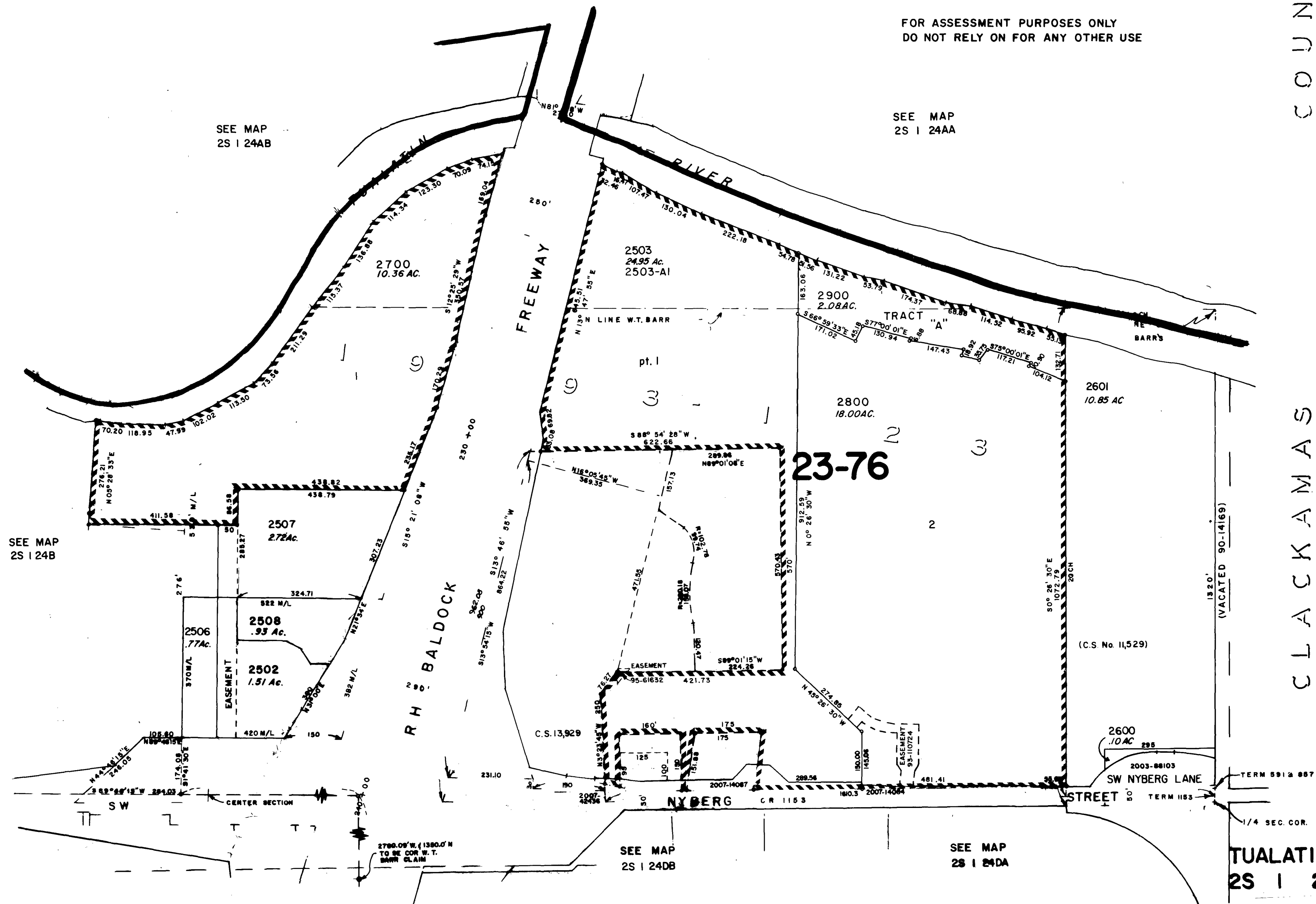

Transportation Impact Analysis

Nyberg Rivers

Tualatin, Oregon

April 2013



KITTELSON & ASSOCIATES, INC.
TRANSPORTATION ENGINEERING/PLANNING

Transportation Impact Analysis

Nyberg Rivers TIA

Tualatin, Oregon

Prepared For:
CenterCal Properties
1600 E. Franklin Avenue
El Segundo, CA 90245

Prepared By:
Kittelson & Associates, Inc.
610 SW Alder, Suite 700
Portland, OR 97205
(503) 228-5230

Project No. 12116

April 2013



TABLE OF CONTENTS

Executive Summary	2
Introduction	7
Existing Conditions	12
Transportation Impact Analysis	24
Conclusions and Recommendations	53

LIST OF FIGURES

Figure 1:	Site Vicinity Map	8
Figure 2:	Redevelopment Site Plan	9
Figure 3a:	Existing Lane Configurations and Traffic Control Devices	13
Figure 3b:	Roadway Ownership Map	14
Figure 4a:	Year 2012 Existing Traffic Conditions, Weekday PM Peak Hour	18
Figure 4b:	Year 2012 Existing Traffic Conditions, Saturday Midday Peak Hour	19
Figure 5a:	Year 2014 Background Traffic Conditions, Weekday PM Peak Hours	26
Figure 5b:	Year 2014 Background Traffic Conditions, Weekday PM Peak Hours	27
Figure 6:	Assumed Site Access Configurations and Traffic Control Devices	31
Figure 7:	Estimated Trip Distribution Pattern	34
Figure 8aA:	Estimated Year 2014 Site-Generated (Added) Traffic Volumes, Weekday PM Peak Hour	36
Figure 8aPB:	Estimated Year 2014 Site-Generated (Pass-by) Traffic Volumes, Weekday PM Peak Hour	37
Figure 8bA:	Estimated Year 2014 Site-Generated (added) Traffic Volumes, Saturday Midday Peak Hour	38
Figure 8bPB:	Estimated Year 2014 Site-Generated (Pass-by) Traffic Volumes, Saturday Midday Peak Hour	39
Figure 9a:	Year 2014 Total Traffic Conditions, Weekday PM Peak Hour	40
Figure 9b:	Year 2014 Total Traffic Conditions, Saturday Midday Peak Hour	41
Figure 10:	Alternative Site Access Configuration and Traffic Control Devices	46
Figure 11a:	Year 2014 Total Traffic Conditions, Alternative Access Configuration, Weekday PM Peak Hour	47
Figure 11b:	Year 2014 Total Traffic Conditions, Alternative Access Configuration Saturday Midday Peak Hour	48

LIST OF TABLES

Table 1:	Existing Transportation Facilities	15
Table 2:	2012 Existing Conditions Operations Summary.....	17
Table 3:	Existing Daily Traffic Volumes on Select Roadway Segments.....	20
Table 4:	Intersection Crash History (January 1, 2009 through December 31, 2011)	22
Table 5:	Historical Traffic Counts.....	24
Table 6:	2014 Background Traffic Conditions.....	28
Table 7:	2014 Background Daily Traffic Profile.....	29
Table 8:	Estimated Nyberg Rivers Trip Generation	33
Table 9:	2014 Total Traffic Operations	42
Table 10:	2014 Total Daily Traffic Profile.....	43
Table 11:	Estimated 95 th Percentile Queuing Analysis	44
Table 12:	SW Martinazzi Avenue/SW Seneca Street Intersection Mitigation (2014 Total Traffic Conditions)	49

Section 1
Executive Summary

EXECUTIVE SUMMARY

CenterCal Properties, LLC is proposing to redevelop a portion of an existing Tualatin retail center located in the northwest quadrant of the I-5/Nyberg Road interchange. The redevelopment, known as Nyberg Rivers, will consist of a reconfiguration of portions of the larger existing shopping center site. The redevelopment plan includes demolition of existing buildings, construction of new retail pads, and the relocation of some existing uses. In addition, several access changes will be made to the site to better accommodate the estimated traffic volumes being generated by the redevelopment. When complete, the proposed redeveloped plan will consist of a maximum total of 307,000 square feet of retail space.

The transportation analysis demonstrates that the proposed Nyberg Rivers redevelopment project can be constructed while maintaining acceptable traffic operations and safety at the study intersections within the immediate site vicinity, assuming provision of the recommended mitigation measures.

FINDINGS

Year 2012 Existing Conditions

- All of the study intersections currently operate acceptably during the weekday p.m. and Saturday midday peak hours with the exception of the SW Martinazzi Avenue/SW Sagert Street and SW 65th Avenue/SW Sagert Road intersections.
 - At both the SW Martinazzi Avenue/SW Sagert Street and SW 65th Avenue/SW Sagert Street intersections, the southbound approach during the weekday p.m. peak hour operates at LOS F.

Year 2014 Background Traffic Conditions

- All of the study intersections are forecast to operate acceptably during the weekday p.m. and Saturday midday peak hours with the exception of SW Martinazzi Avenue/SW Sagert Road and SW 65th Avenue/SW Sagert Road intersections.
 - At both the SW Martinazzi Avenue/SW Sagert Street and SW 65th Avenue/SW Sagert Street intersections, the southbound approach during the weekday p.m. peak hour is forecast to continue to operate at LOS F. These findings are consistent with analysis conducted as part of the recent Tualatin Transportation System Plan (TSP) Update and future improvements are identified within the TSP for both of these intersections.

Proposed Redevelopment Plan

- Under the redevelopment plan, the existing SW 75th Avenue connection to SW Nyberg Road will be closed to improve access management along SW Nyberg Road and to better accommodate the redevelopment proposal.
- The existing signalized access on SW Nyberg Road that currently serves the shopping center and the adjacent Fred Meyer site will remain. However, the following changes are proposed in order to better accommodate the proposed redevelopment, provide additional capacity for future growth in traffic, and improve safety relative to the existing condition:
 - A westbound right-turn lane will be developed on SW Nyberg Road to enhance access to the site and minimize vehicle queuing on SW Nyberg Road.
 - The existing site driveway is proposed to be widened as shown in the proposed site plan. This widening will include dual southbound left-turn lanes, a shared through/right-turn lane, and dual in-bound receiving lanes. A raised median will be constructed in the driveway throat to reduce turning conflicts on-site turning maneuvers and manage vehicle queues on the approach to the signal.
 - The north and south approach signal phasing is proposed to be modified from permissive left-turn phasing to split phasing.
- With the anticipated mix of new retail uses, the proposed redevelopment is estimated to generate 405 net new trips during the weekday p.m. peak hour and 725 net new trips during the Saturday midday peak hour.

Year 2014 Total Traffic Conditions

- All of the study intersections within the immediate site vicinity, including the site access points and internal site intersections, are forecast to operate acceptably during the weekday p.m. and Saturday midday peak hours.
- The SW Martinazzi Avenue/SW Sagert Road and SW 65th Avenue/SW Sagert Road intersections are forecast to continue to operate at LOS F.
 - The proposed development will have an insignificant impact at either intersection, resulting in an estimated 1.6% and 0.6% increase, respectively, during the weekday p.m. peak hour.
 - The Tualatin TSP has identified mitigations for these two intersections that, when implemented, will address the long-term operations.
 - The Washington County Transportation Development Tax (TDT) in part funds an improvement project on SW Sagert Street that will add capacity and reduce delay to both intersections.
- Beyond the site's frontage along SW Tualatin Sherwood Road and SW Martinazzi Avenue, where significant transportation improvements are proposed (including implementing the

- intent of the City's Loop Road), the project will have an insignificant impact on the other study intersections (generally resulting in less than a two percent increase in traffic relative to 2014 background conditions).
- At all signalized intersections beyond the site frontage (with the exception of the I-5 interchange), the project will add on average one vehicle or less per signal cycle to any movement. This level of impact is less than significant by any traffic engineering standard and well below the level that would be perceived by motorists.
 - Anticipated vehicle queues can be accommodated at the I-5 ramp terminals and the SW Nyberg Road/Signalized site driveway.
 - The proposed Nyberg Rivers redevelopment project has proposed an on-site roadway network that will meet the intent of the loop road connection. The proposal includes the following:
 - A new roadway connection to SW Boones Ferry Road (shown as "Street A" in Figure 2) that includes sidewalks.
 - An enhanced site-access driveway to SW Nyberg Road that will better accommodate vehicular queuing and demand.
 - A potential future (assuming the City desires to move forward) new site-access connection to SW Martinazzi Avenue that aligns across from SW Seneca Street. This connection would be the Seneca Street extension envisioned in the Town Center Plan. Prior to the City making a decision on any new SW Street Seneca alignment, the redevelopment site plan preserves this connection opportunity in the present or future.
 - The preservation of east-west and north-south travel ways that will provide vehicular and pedestrian access between Street A, the Seneca Street alignment/extension, and enhanced access to SW Nyberg Road.
 - New sidewalks along the enhanced site-access driveway to SW Nyberg Road that provide pedestrian connections to the integrated site circulation network.
 - New bikeway connections along the perimeter of the site.

SW Martinazzi Avenue and SW Boones Ferry Road Site Access Alternatives

- An alternative site access scenario was evaluated that demonstrates the impact of potentially adding a fourth leg (in the form of a site-access driveway) to the existing SW Martinazzi Avenue/SW Seneca Street intersection and closing the existing SW Martinazzi Avenue site driveway adjacent to the library. This analysis produced the following results:
 - The east and west approaches to a modified SW Martinazzi Avenue/SW Seneca Street intersection would operate at Level of Service (LOS) F and over capacity during the

weekday p.m. peak hour with the addition of a fourth site-access leg. Signalizing the intersection would provide the following:

- Mitigation that results in LOS A or better (a significant improvement over existing conditions).
 - Additional excess intersection capacity beyond what is needed to serve the Nyberg Rivers project traffic.
 - Enhanced east-west pedestrian connectivity across SW Martinazzi Avenue.
 - A safety improvement relative to stop sign control.
- In addition to the modified SW Martinazzi Avenue/SW Seneca Street intersection, another site-access alternative was evaluated that demonstrates the impacts of adding a limited access site-driveway to SW Boones Ferry Road. The analysis shows that with a direct connection to SW Boones Ferry Road, there would be some shifting of site-generated traffic off of SW Martinazzi Avenue. This additional access would further improve connectivity, help implement the City's loop road concept, and provide additional capacity beyond what is needed to serve the Nyberg Rivers project.

RECOMMENDATIONS

- With the proposed Nyberg Rivers redevelopment:
- The existing SW 75th Avenue site-access driveway to SW Nyberg Road should be closed in order to minimize turning movement conflicts, allow for the construction of a westbound right-turn lane at the SW Nyberg Road/signalized site driveway, and improve the interchange access spacing conditions along SW Nyberg Road.
 - To better accommodate the anticipated site-generated traffic at the SW Nyberg Road/Signalized site driveway:
 - A new westbound right-turn lane should be constructed on SW Nyberg Road.
 - The site driveway should be modified to include dual southbound left-turn lanes, a shared through/right-turn lane, and two inbound receiving lanes.
 - The existing north/south traffic signal phasing should be modified from permissive phasing to split phasing. Right-turn overlap phasing should be provided for the westbound right-turn movement into the Nyberg Rivers site.
- If site access to SW Martinazzi Avenue is provided via a new fourth leg to the SW Martinazzi Avenue/SW Seneca Street intersection, the intersection should be signalized.
- If a new site access driveway is provided to SW Boones Ferry Road, the driveway should be limited to right-in/right-out only access.

Section 2
Introduction

INTRODUCTION

PROJECT DESCRIPTION

CenterCal Properties, LLC is proposing to redevelop a portion of the existing Tualatin shopping center located in the northwest quadrant of the I-5/Nyberg Road interchange. The existing shopping center has been anchored by K-Mart and includes an assortment of other supporting retail uses such as drive-thru banks, fast-food restaurants, and small to medium miscellaneous retailers. The Tualatin City Hall and Library is also located within the boundary of the shopping center site, but on its own legal lot of record and in separate ownership than the shopping center. Figure 1 illustrates the location of the site in relationship to the larger regional vicinity.

In an effort to enhance and reinvigorate the existing shopping center, CenterCal is proposing to redevelop the center as shown in Figure 2. Known as the Nyberg Rivers project, the full redevelopment vision will entail the following components:

- The existing 96,799 square foot former K-Mart building will be removed.
- The existing 3,500 square foot building currently occupied by a Wendy's will be relocated to a new pad within the shopping center site.
- All other existing buildings will remain and it has been assumed that the existing tenants will continue to operate as-is for the foreseeable future.
- While a specific tenant mix is still being developed by CenterCal, it is envisioned that the redevelopment will include a large retailer and an assortment of small and medium-sized retail/restaurant uses. For the purposes of this traffic study, it has been assumed that this mix of uses will total approximately 245,456 square feet of new leasable area bringing the total net leasable square footage for the entire shopping center to 307,000.
- The existing SW 75th Avenue access to SW Nyberg Road is proposed to be closed.
- The existing signalized access on SW Nyberg Road that currently serves the shopping center will remain and continue to serve as the main entrance.
- All other shopping center driveways located off of SW Nyberg Road and SW Martinazzi Avenue will remain.
- While not required under this proposal, in consultation and cooperation with the City of Tualatin, the existing SW Martinazzi Avenue driveway (adjacent to the library/city hall) could close and alternative access could be provided via a new driveway across from SW Seneca Street. This option would only be pursued if it was with the mutual agreement of the City and on a timeline acceptable to the City.

Redevelopment construction is expected to begin in 2013 and with completion and full occupancy anticipated in 2014.



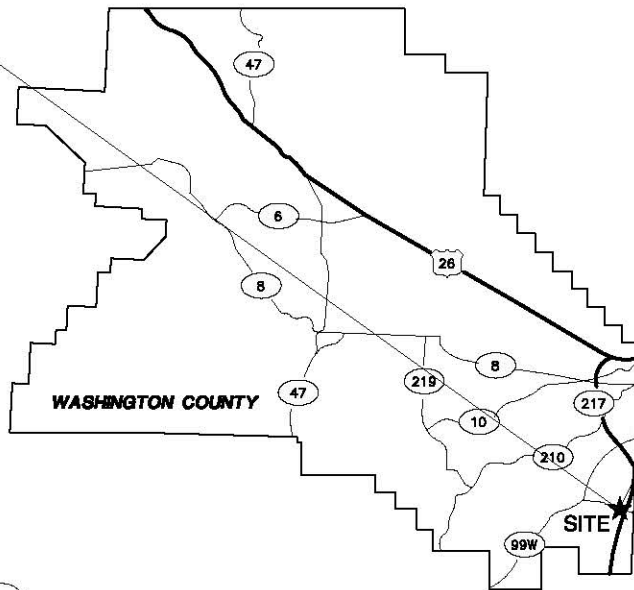
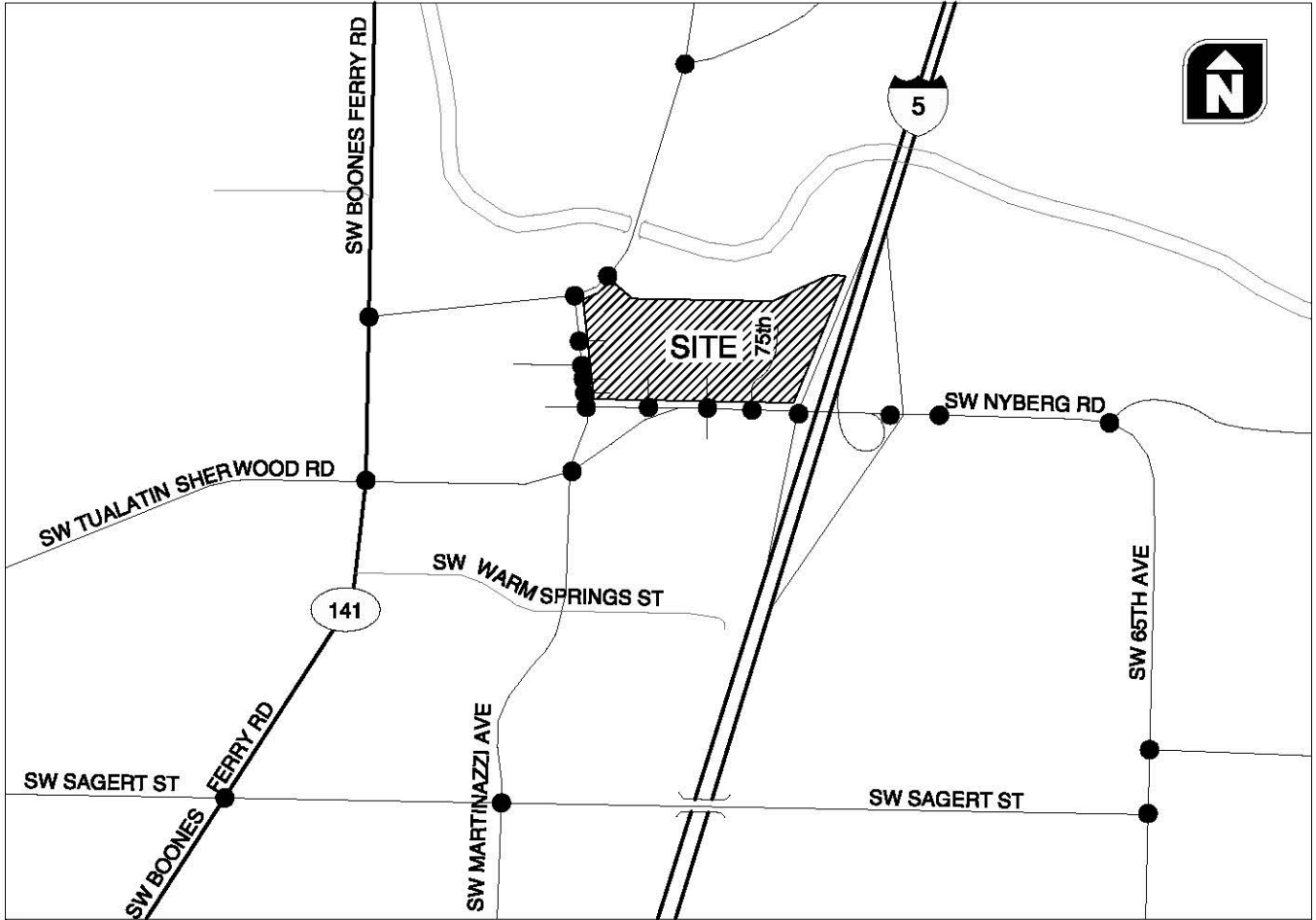

LEGEND

- - STUDY INTERSECTIONS

SITE VICINITY MAP
TUALATIN, OREGON

FIGURE
1

H:\projfile\12116 - K-Mart Tualatin Redevelopment\dwg\figs\April2013\12116_Fig01.dwg Apr 15, 2013 - 4:07pm - mhughart Layout Tab: Fig01

H:\profiles\12116 - K-Mart Tualatin Redevelopment\dwgs\figs\April2013\12116_Fig01.dwg Apr 15, 2013 - 4:09pm - mhughart Layout Tab: Fig02



PROJECT SUMMARY

MASTER PLAN AREA:	38.72 ACRES
FUTURE DEVELOPMENT AREA:	6.81 ACRES
By others:	
UNUSUALLY DEVELOPABLE AREA:	31.91 ACRES
CONSERVATION AREA:	6.00 ACRES
NET AREA:	25.91 ACRES
REQUIRED LANDSCAPE AREA:	1.58 / 4.78 ACRES
LANDSCAPE AREA PROVIDED:	9.03 ACRES
FLOOR AREA RATIO:	0.24
TOTAL FPMFIS B/F:	
BUILDING AREA:	307,000 SF
BUILDING AREA:	
BLDG 1005:	30,000 SF
BLDG 1010:	21,750 SF
BLDG 1030:	2,900 SF
BLDG 1040:	110,000 SF
BLDG A:	12,500 SF
BLDG B:	5,850 SF
BLDG C:	3,950 SF
BLDG D:	32,429 SF
BLDG E:	2,280 SF
BLDG F:	5,000 SF
BLDG G 102:	6,620 SF
BLDG H 100:	4,370 SF
BLDG J - DE:	5,734 SF
BLDG W-100:	8,680 SF
BLDG W-120:	43,000 SF
TOTAL:	297,807 SF
ADDITIONAL POTENTIAL BUILDING AREA:	9,193 SF
TOTAL PROVIDED STALLS:	1,297 stalls
PARKING S.A.-L:	4.36 / 100'S
PARKING S.A.-L STANDARDS:	9.4' X 19.8'
DIMENSIONS:	COMPACT 7.74' X 15.4'

Notes:

- "Site Area" includes only the areas of Tualatin Riverwa Blocks that are subject of the development proposal. Other phases of the Master Plan may be developed by others.
- Required Landscaping is based on Gross Site Area.
- Building areas and stalls may differ from actual footprint size to allow for interior walls and architectural elements.



Nyberg Rivers DRAFT

Concept Plan - 19V1c - Dual Entry Lanes

Tualatin, Oregon

PROPOSED SITE PLAN
TUALATIN, OREGON

FIGURE
2

SCOPE OF THE REPORT

This analysis determines the transportation-related impacts associated with the proposed Nyberg Rivers redevelopment and was prepared in accordance with the City of Tualatin, Washington County, and Oregon Department of Transportation (ODOT) requirements for traffic impact studies. The study intersections and scope of this project were selected in consultation with City, County, and ODOT staff. Appendix A contains a copy of the traffic impact study scoping letter and feedback received from the agency staff. Based on this correspondence, this study contains the following elements:

- Year 2012 existing land-use and transportation-system conditions within the site vicinity during the weekday p.m. and Saturday midday peak periods;
- Forecast year 2014 background traffic conditions during the weekday p.m. and Saturday midday peak periods;
- Trip generation and distribution estimates for the proposed Nyberg Rivers redevelopment;
- Forecast year 2014 total traffic conditions during the weekday p.m. and Saturday midday peak periods with build-out of the site;
- Vehicle queuing operations at the Nyberg Road site access driveway and the I-5 off-ramps;
- On-site traffic operations and circulation; and
- Recommendations

Section 3
Existing Conditions

EXISTING CONDITIONS

The existing conditions analysis identifies the site conditions and current operational and geometric characteristics of the roadways within the study area. These conditions will be compared with future conditions later in this report.

Kittelson & Associates, Inc. (KAI) staff visited and inventoried the proposed Nyberg Rivers redevelopment site and surrounding study area. At that time, KAI collected information regarding site conditions, adjacent land uses, existing traffic operations, and transportation facilities in the study area.

SITE CONDITIONS AND ADJACENT LAND USES

As shown in Figure 1, the existing shopping center is located in the northwest quadrant of the I-5/Nyberg Road interchange in Tualatin. The shopping center is bounded by Nyberg Road to the south, I-5 to the east, SW Martinazzi Avenue to the west, and Boones Ferry Road/Tualatin River to the north. The shopping center currently consists of an unoccupied former K-Mart, two drive-thru banks, a fast-food restaurant, and an assortment of retail uses. In addition, the Tualatin City Hall, city administrative offices, and public library are located in the northwest portion of the shopping center site on City-owned property and a separate legal lot of record.

TRANSPORTATION FACILITIES

Table 1 identifies the characteristics of key roadways located within the vicinity of the redevelopment site. Figure 3a identifies the existing lane configurations and traffic control devices at all of the study intersections while Figure 3b identifies the study area roadway ownership.

H:\proj\12116 - K-Merit Tualatin Redevelopment\figs\April2013\12116_Fig01.dwg Apr 15, 2013 - 4:09pm - mhughart Layout Tab: Fig03A

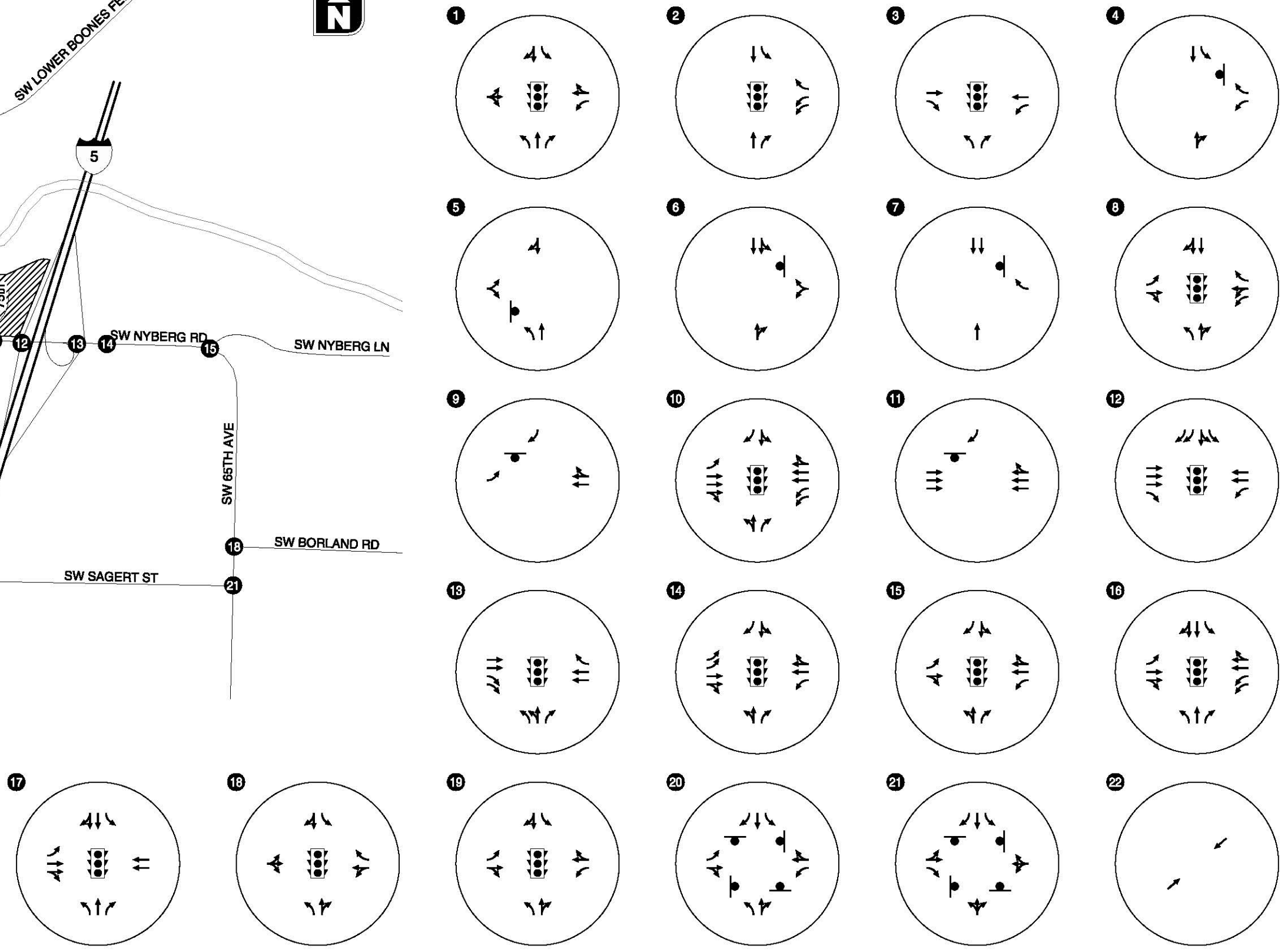
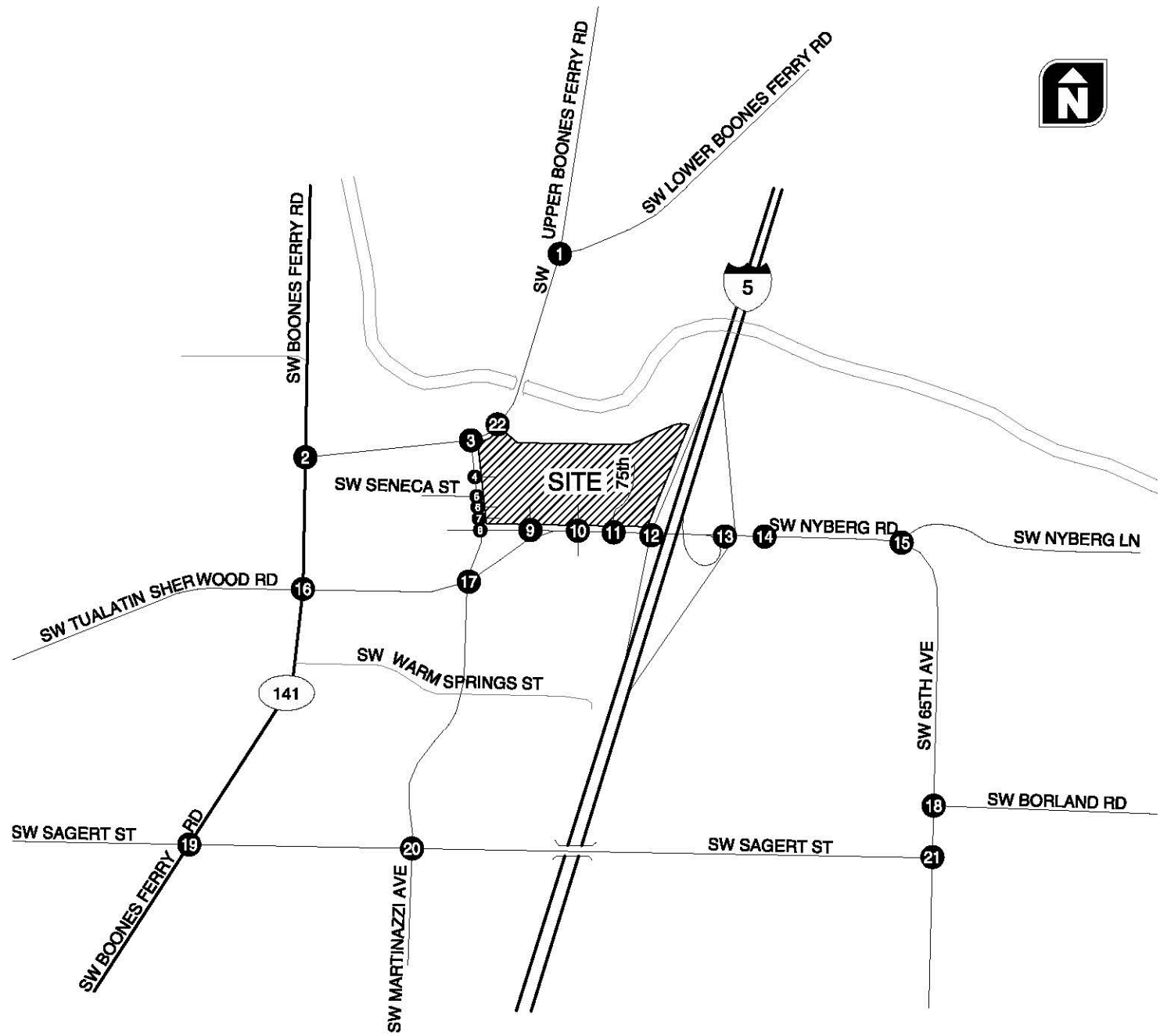

LEGEND

-  - STOP SIGN
-  - TRAFFIC SIGNAL

EXISTING LANE CONFIGURATIONS AND TRAFFIC CONTROL DEVICES TUALATIN, OREGON

FIGURE 3A



H:\profiles\12116 - K-Mart Tualatin Redevelopment\dwgs\figs\April2013\12116_Fig01.dwg Apr 15, 2013 - 4:05pm - mhughart Layout Tab: Fig03B

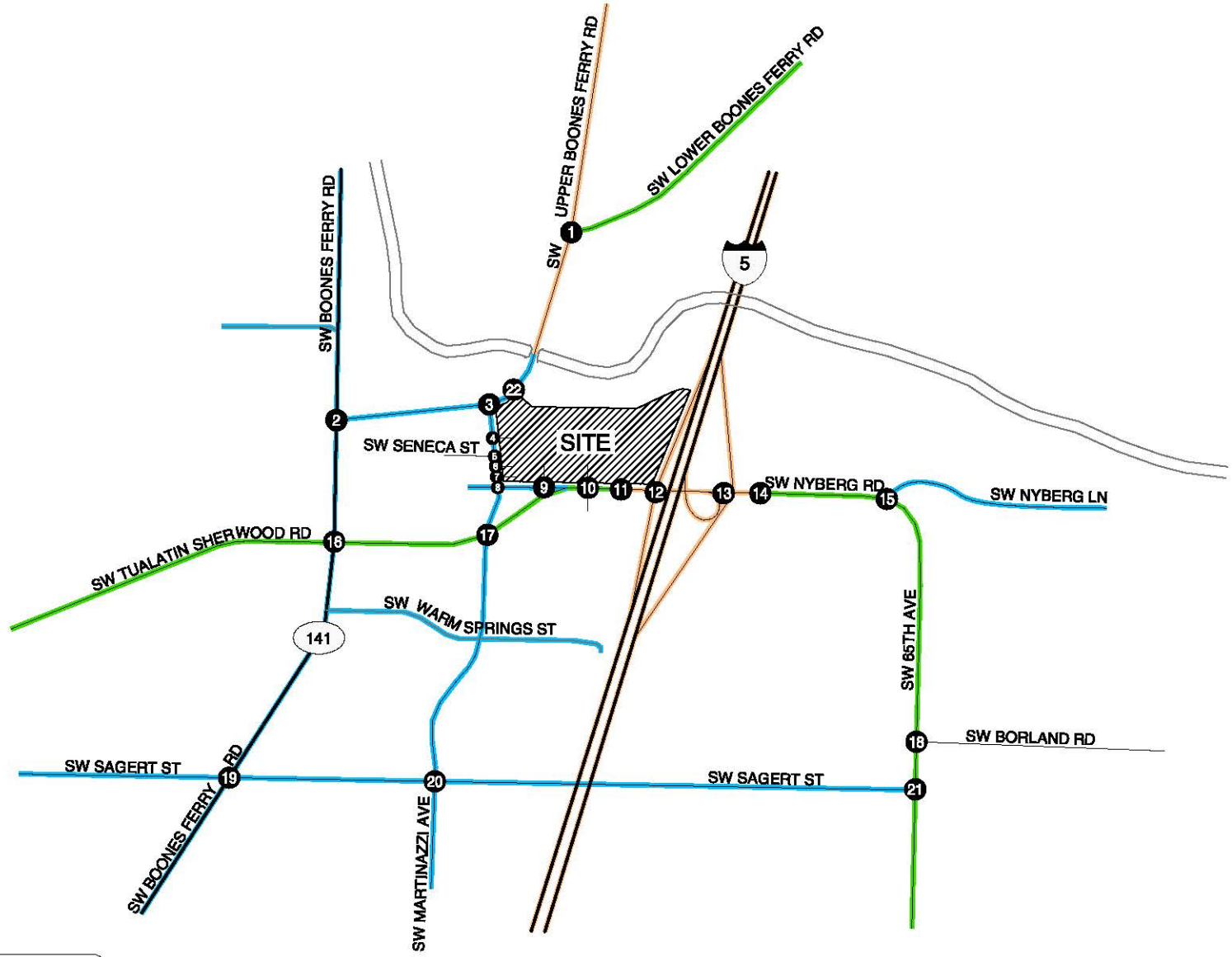

LEGEND

- ODOT
- Washington County
- City of Tualatin

ROADWAY OWNERSHIP MAP
TUALATIN, OREGON **FIGURE 3B**

Table 1: Existing Transportation Facilities

Roadway	Functional Classification (By Jurisdiction)	Number of Lanes	Posted Speed (mph)	Sidewalks	Bicycle Lanes	On-Street Parking
I-5	Interstate Highway - (ODOT)	7-8 lanes	55	No	No	No
SW Nyberg Road	Arterial (east of T-S Road) - (Washington County) ¹	6 lanes	30	Yes	Yes	No
	Minor Collector (west of T-S Road) – (Tualatin)	2 lanes	30	Yes	No	No
Tualatin-Sherwood Road	Arterial – (Washington County)	5 lanes	35	Yes	No	No
SW Martinazzi Avenue	Minor Arterial (north of T-S Road) – (Tualatin)	3 lanes	NP	Yes	No	No
	Major Arterial (south of T-S Road) – (Tualatin)	5 lanes	35	Yes	No	No
Boones Ferry Road	Major Arterial (east of Martinazzi) – (Tualatin)	3 lanes	35	Yes	Yes	No
	Minor Arterial (west of Martinazzi) – (Tualatin)	3 lanes	30	Yes	Yes	No
	Major Arterial (south of Tualatin Road) – (Tualatin)	2-4 lanes	30-35	Yes	Yes	No
Lower Boones Ferry Road	Minor Arterial – (Tualatin)	3 lanes	35	Yes	Yes	No
Upper Boones Ferry Road	District Highway – (ODOT)	3 lanes	35	Yes	Yes	No
SW Seneca Street	Local Commercial – (Tualatin)	2 lanes	NP	Yes	No	No
SW 65 th Avenue	Major Arterial – (Tualatin)	3 lanes	35	Yes	No	No
SW Sagert Street	Major Arterial – (Tualatin) (east of SW Martinazzi Ave)	2-3 lanes	35 ²	Yes	Yes	No
	Major Collector – (Tualatin) (west of SW Martinazzi Ave)					
	Minor Arterial – (Tualatin) (west of SW Boones Ferry Rd)					
SW Borland Rd	Major Arterial – (Tualatin)	2-3 lanes	35	Yes	Yes ³	No
	Minor Arterial (Clackamas County)					

Notes:

¹ ODOT has jurisdictional control over SW Nyberg Road within the vicinity of the northbound and southbound I-5 ramp terminals² 30 mph west of SW Martinazzi Avenue³ There are no bicycle lanes within the vicinity of the SW 65th Avenue intersection

NP = Not Posted

T-S Road = Tualatin-Sherwood Road

TRAFFIC VOLUMES AND PEAK HOUR OPERATIONS

In late May 2012 (while local schools were still in session), manual turning-movement counts were obtained for the all the study intersections and site driveways located within the immediate vicinity of the shopping center. In addition, traffic count data collected as part of the on-going Tualatin Transportation System Plan Update were utilized for all of the other study intersections¹. Figures 4a and 4b provide a summary of the existing turning-movement counts, which are rounded to the nearest five vehicles per hour for the weekday p.m. and Saturday midday peak hours. *Appendix “B” contains the traffic count worksheets used in this study.*

¹ Saturday midday counts were only collected at the site-access driveways and adjacent study area intersections.

Operational Standards

Level of service (LOS) and volume-to-capacity (V/C) ratio are the two performance measures utilized by the affected review agencies for determining intersection operations. A description of each is outlined below.

Level of Service

All level-of-service analyses described in this report were performed in accordance with the procedures stated in the 2000 *Highway Capacity Manual*. A description of level of service and the criteria by which they are determined is presented in Appendix "C". Appendix "C" also indicates how level of service is measured and what is generally considered the acceptable range of level of service. The City of Tualatin has adopted level-of-service standards for signalized and unsignalized intersections. LOS "D" is considered acceptable at signalized intersections and LOS "E" is considered acceptable at an unsignalized intersections.

V/C Ratio

The V/C ratio is a measure of an intersection's theoretical capacity. As the V/C ratio approaches 1.0, vehicle congestion worsens and the intersection becomes less capable of accommodating the vehicular demand. For all of the Washington County study intersections, the maximum acceptable V/C ratio is 0.99 during the first hour and 0.90 during second hour. For the ODOT study intersections, the minimum acceptable V/C ratio is 0.99.

All intersection level-of-service evaluations used the peak 15-minute flow rate during the weekday p.m. and Saturday midday peak hours. Using the peak 15-minute flow rate ensures that this analysis is based on a reasonable worst-case scenario. For this reason, the analysis reflects conditions that are only likely to occur for 15 minutes out of each average peak hour. The transportation system will likely operate under conditions better than those described in this report during all other time periods.

Figures 4a, 4b, and Table 2 summarize the operational performance for the study intersections under the existing peak hour conditions. As shown, all of the study intersections currently operate at acceptable levels of service and V/C ratios during the peak hours with the exception of the SW Martinazzi Avenue/SW Sagert Road and SW 65th Avenue/SW Sagert Road intersections. Appendix "D" includes the operational worksheets under year 2012 existing traffic conditions.

Table 2: 2012 Existing Conditions Operations Summary

Number	Intersection	Maximum Operating Standard	Weekday PM Peak Hour		Saturday Midday Peak Hour	
			LOS	V/C	LOS	V/C
Signalized Intersections						
1	SW Upper Boones Ferry Road/ SW Lower Boones Ferry Road/ SW Boones Ferry Road	0.99	C	0.74	Not Analyzed	Not Analyzed
2	SW Boones Ferry Road/ SW Tualatin Road	0.99	B	0.58	Not Analyzed	Not Analyzed
3	SW Boones Ferry Road/ SW Martinazzi Avenue	0.99	C	0.91	B	0.64
8	SW Nyberg Road/ SW Martinazzi Avenue	0.99	B	0.51	B	0.39
10	SW Nyberg Road/ SW Tualatin-Sherwood Road/ Fred Meyer/Site Access	0.99	B	0.80	B	0.66
12	I-5 SB Ramp Terminal/ SW Nyberg Road	0.85	C	0.80	C	0.77
13	I-5 NB Ramp Terminal/ SW Nyberg Road	0.85	B	0.60	C	0.55
14	SW Nyberg Road/ Nyberg Woods Driveway	0.99	B	0.70	B	0.64
15	SW Nyberg Road/ SW 65 th Avenue	0.99	C	0.75	Not Analyzed	Not Analyzed
16	SW Tualatin-Sherwood Road/ SW Boones Ferry Road	0.99	D	0.82	Not Analyzed	Not Analyzed
17	SW Tualatin-Sherwood Road/ SW Martinazzi Avenue	0.99	D	0.85	C	0.76
18	SW 65 th Avenue/ SW Borland Road	0.99	D	0.88	Not Analyzed	Not Analyzed
19	SW Boones Ferry Road/ SW Sagert Street	0.99	C	0.68	Not Analyzed	Not Analyzed
Unsignalized Intersections¹						
4	SW Martinazzi Avenue/ North Site Driveway	E	C	0.11	B	0.11
5	SW Martinazzi Avenue/ SW Seneca Street	E	D	0.50	C	0.22
6	SW Martinazzi Avenue/ Site Driveway	E	C	0.10	B	0.07
7	SW Martinazzi Avenue/ Right-Out Only Site Driveway	E	B	0.04	B	0.02
9	SW Nyberg Road/ Site Driveway	E	B	0.15	B	0.08
11	SW Nyberg Road/ Right-in Right-Out Site Driveway	0.99	A	0.01	A	0.02
All-Way Stop controlled Intersections						
20	SW Sagert Street/ SW Martinazzi Avenue	D	F	N/A	Not Analyzed	Not Analyzed
21	SW Sagert Street/ SW 65 th Avenue	D	F	N/A	Not Analyzed	Not Analyzed

Notes:

¹ LOS and V/C reported for the highest delay or critical movement

For intersections #4, #5, #6, and #7, it is recognized that the operational results shown may differ slightly due to the presence of vehicle queuing along SW Martinazzi Avenue during peak time periods.



H:\projects\12116 - K-Mer Tualatin Redevelopment\chgs\Apr16, 2013 - 2:37pm - mhughart Layout Tab: Fig04A

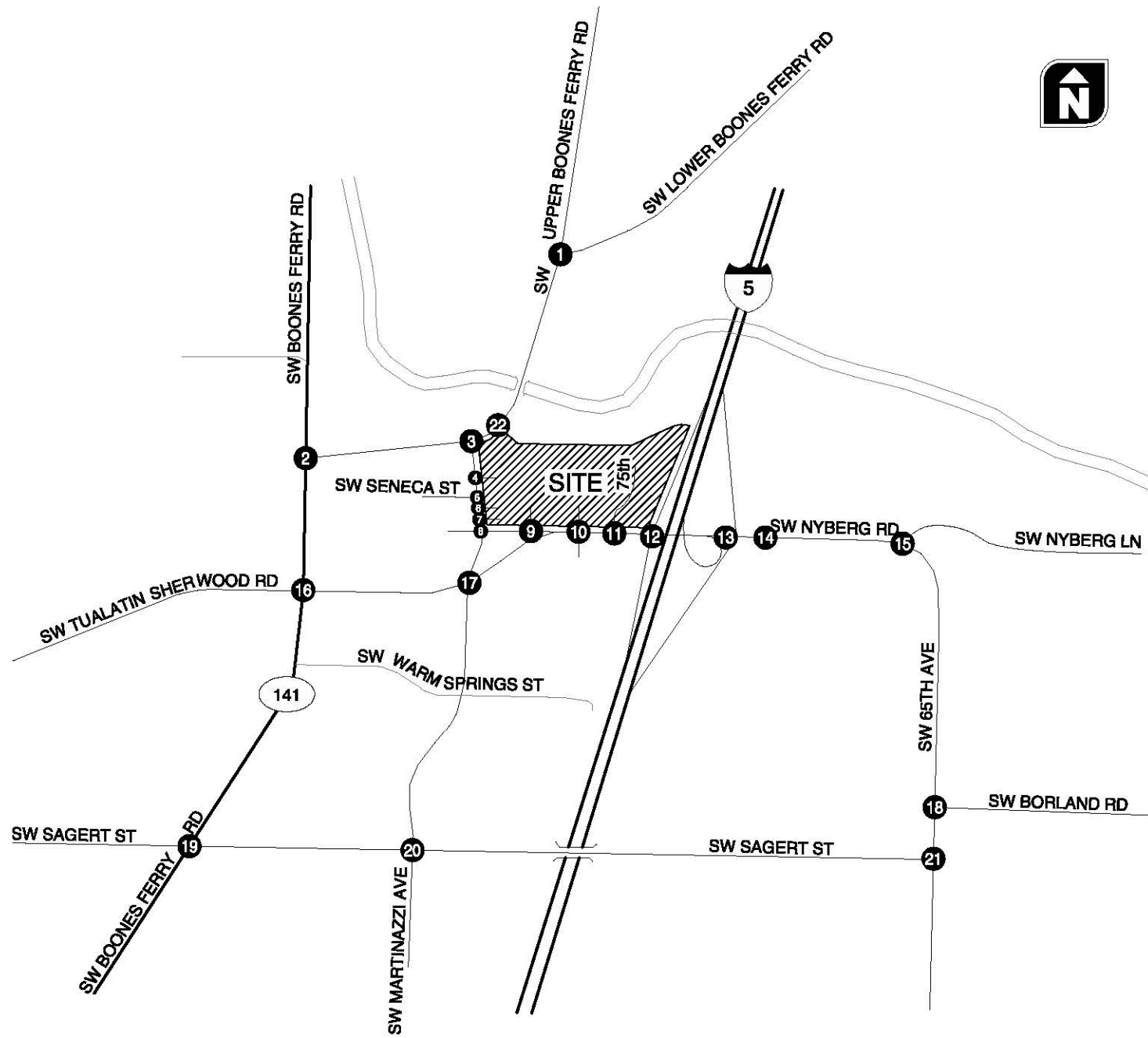

LEGEND

- CM = CRITICAL MOVEMENT (TWSC)
- LOS = INTERSECTION LEVEL OF SERVICE (SIGNALIZED/AWSC)/CRITICAL MOVEMENT LEVEL OF SERVICE (TWSC)
- Del = INTERSECTION AVERAGE CONTROL DELAY (SIGNALIZED/AWSC) / CRITICAL MOVEMENT CONTROL DELAY (TWSC)
- V/C = CRITICAL VOLUME-TO-CAPACITY RATIO
- TWSC = TWO-WAY STOP CONTROL
- AWSC = ALL-WAY STOP CONTROL

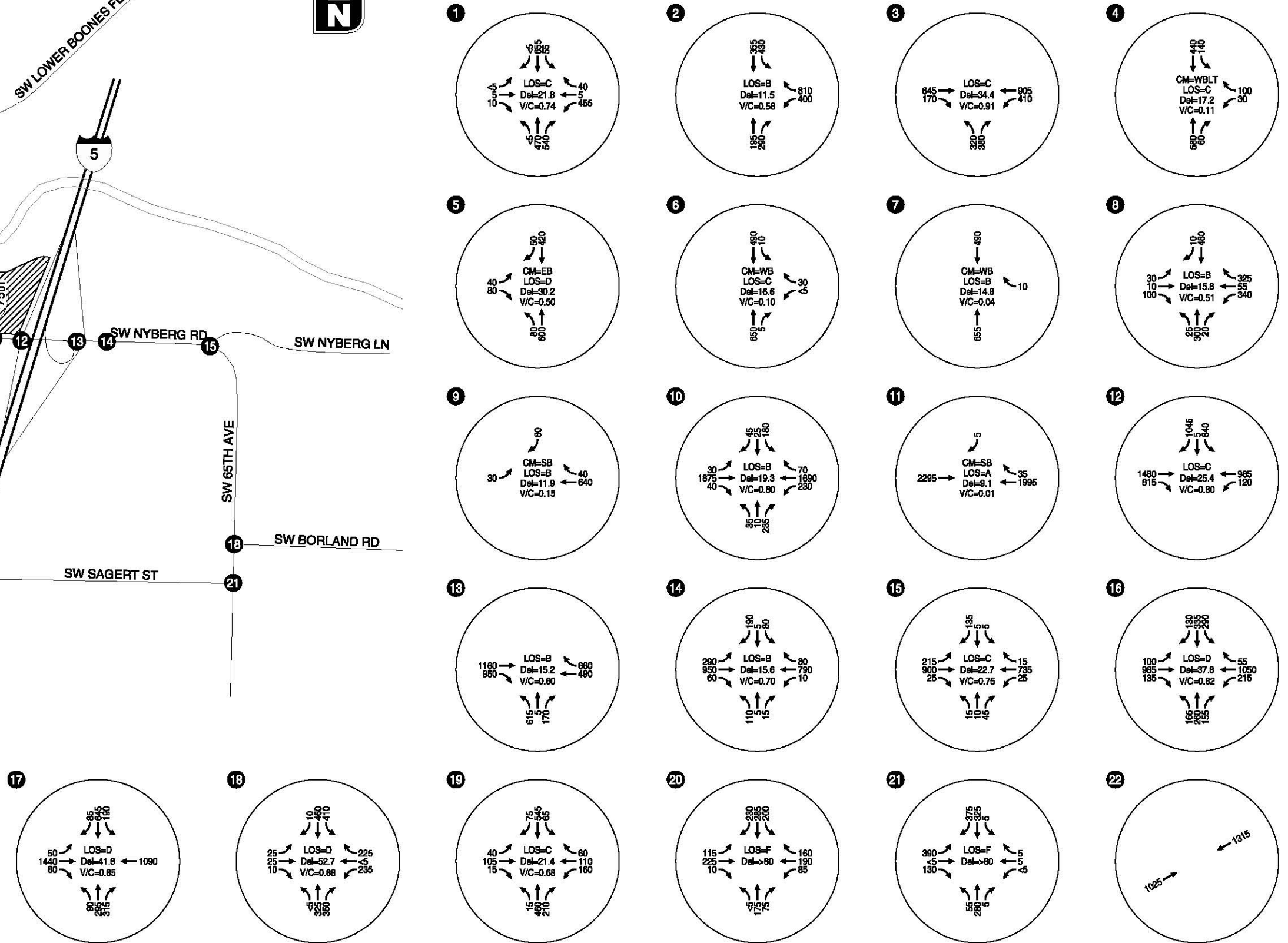

EXISTING TRAFFIC CONDITIONS, WEEKDAY PM PEAK HOUR TUALATIN, OREGON

FIGURE 4A

H:\proj\12116 - K-Mer Tualatin Redevelopment\chgs\Apr17\2013\12116_Fig01.dwg Apr 17, 2013 - 12:41pm - mhughart Layout Tab: Fig04B

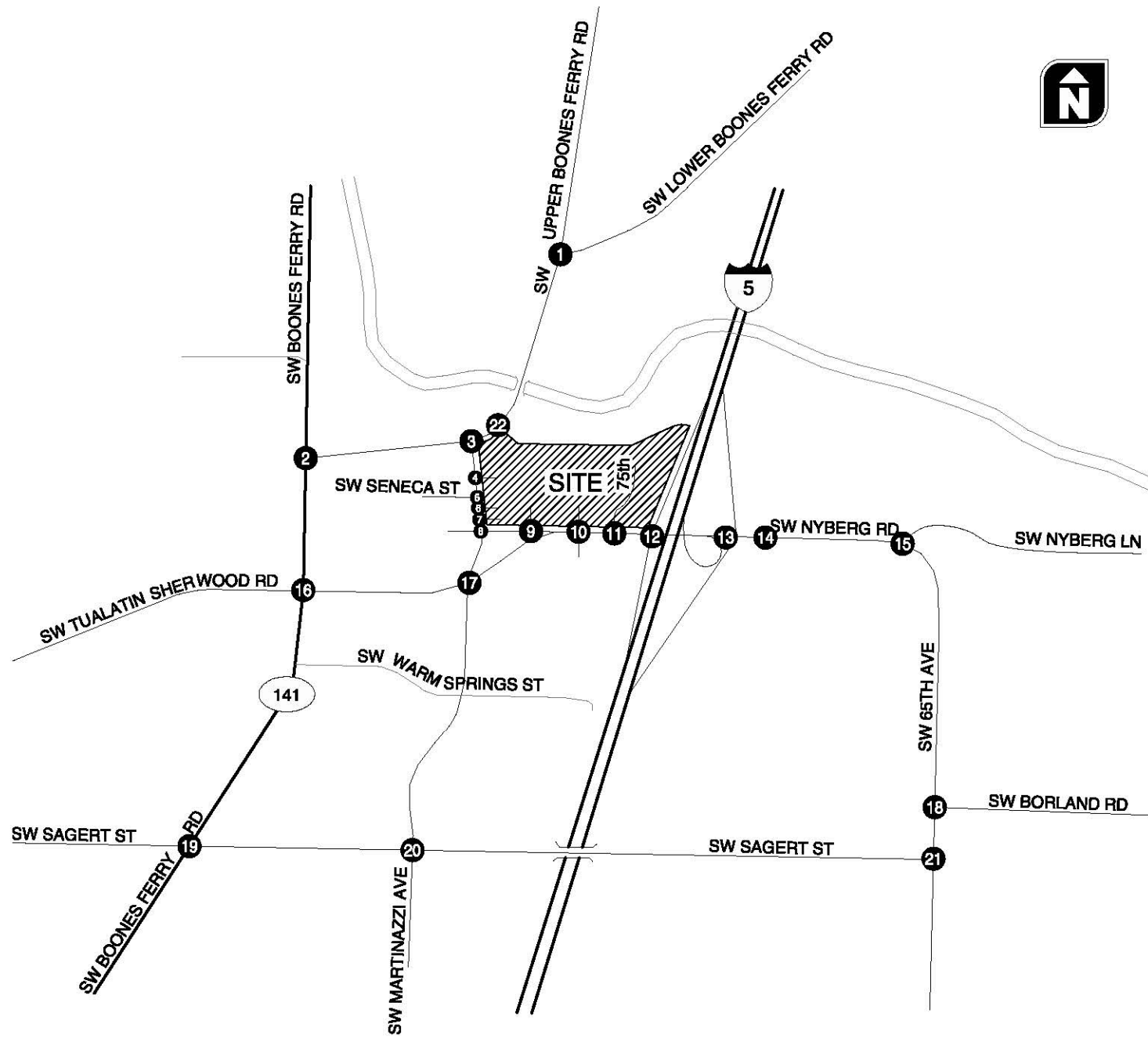

LEGEND

- CM = CRITICAL MOVEMENT (TWSC)
- LOS = INTERSECTION LEVEL OF SERVICE (SIGNALIZED/AWSC)/CRITICAL MOVEMENT LEVEL OF SERVICE (TWSC)
- Del = INTERSECTION AVERAGE CONTROL DELAY (SIGNALIZED/AWSC) / CRITICAL MOVEMENT CONTROL DELAY (TWSC)
- V/C = CRITICAL VOLUME-TO-CAPACITY RATIO
- TWSC = TWO-WAY STOP CONTROL
- AWSC = ALL-WAY STOP CONTROL

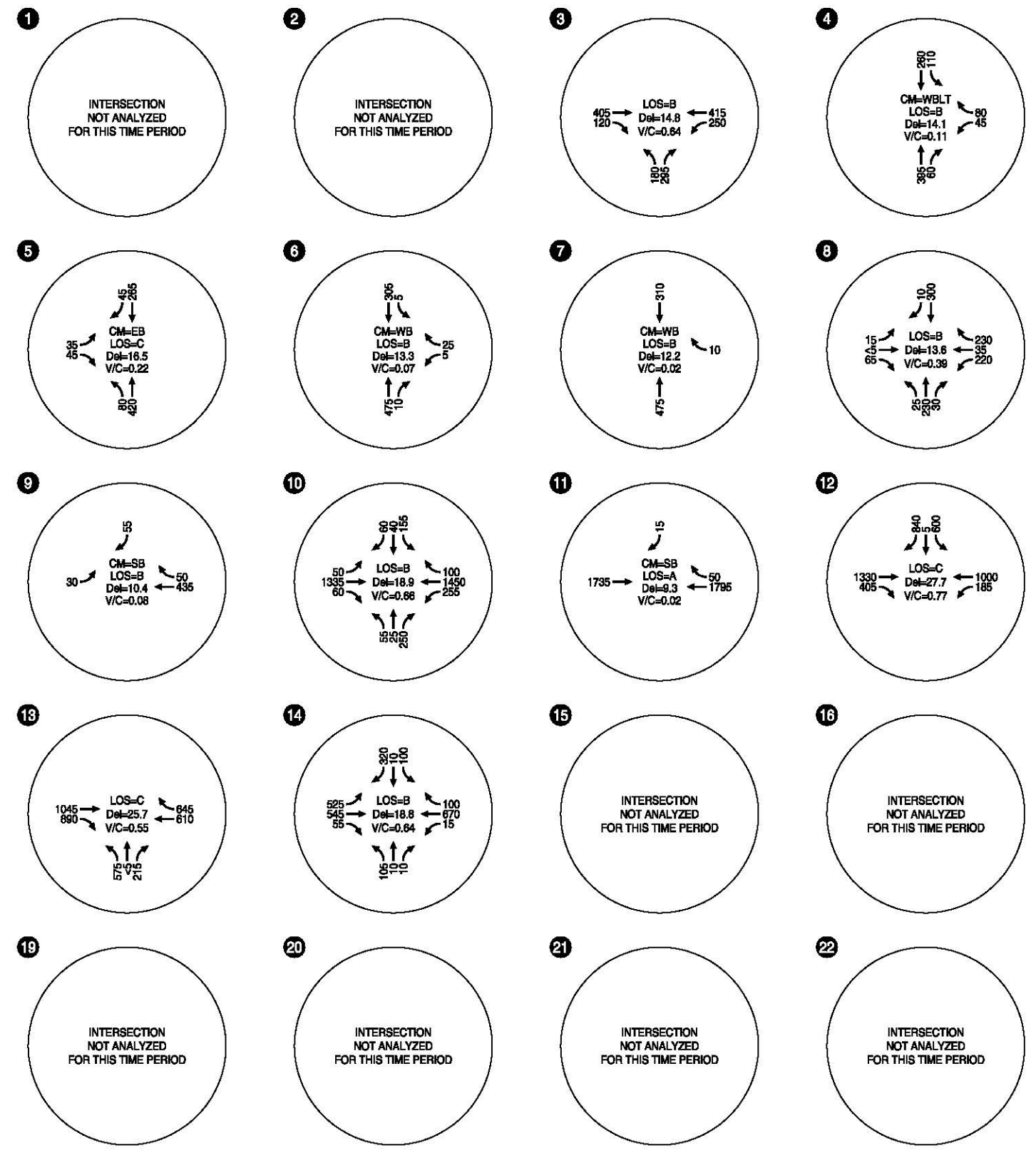

EXISTING SATURDAY MIDDAY PEAK TRAFFIC VOLUMES TUALATIN, OREGON

FIGURE 4B

SW 65th Avenue/SW Sagert Street

The SW 65th Avenue/SW Sagert Street intersection is an all-way stop-controlled intersection. Based on the existing traffic demand, the intersection currently operates at LOS F conditions during the weekday p.m. peak hour. These findings are consistent with the existing conditions analysis prepared as part of the recent update to the Tualatin Transportation System Plan (TSP).

SW Martinazzi Avenue/SW Sagert Road

The SW Martinazzi Avenue/SW Sagert Street intersection is an all-way stop-controlled intersection. Based on the existing traffic demand, the intersection currently operates at LOS F conditions during the weekday p.m. peak hour. These findings are consistent with existing conditions analysis prepared as part of the recent update to the Tualatin TSP.

Existing Daily Traffic Profile

A summation of daily traffic volumes was prepared at the request of the City of Tualatin. Using available daily traffic volume counts collected by Washington County and those daily counts collected as part of the on-going Tualatin Transportation System Plan Update, it was generally determined that the weekday p.m. peak hour traffic volumes are approximately 8% of the daily traffic profile. Applying this factor to the weekday p.m. peak hour turning movement volumes collected at the study area intersections, daily traffic volume estimates were derived and summarized in Table 3.

Table 3: Existing Daily Traffic Volumes on Select Roadway Segments

Roadway	Segment	Estimated Daily Volume
SW Lower Boones Ferry Road	East of SW Upper Boones Ferry Road	13,200
SW Boones Ferry Road	East of SW Martinazzi Avenue	28,100
SW Boones Ferry Road	West of SW Martinazzi Avenue	24,400
SW Martinazzi Avenue	South of SW Boones Ferry Road and north of SW Nyberg Road	13,700
SW Martinazzi Avenue	South of SW Tualatin-Sherwood Road	17,100
SW Boones Ferry Road	North of SW Tualatin-Sherwood Road	14,000
SW Boones Ferry Road	South of SW Tualatin-Sherwood Road	15,200
SW Tualatin-Sherwood Road	West of SW Boones Ferry Road	30,800
SW Tualatin-Sherwood Road	East of SW Boones Ferry Road and west of SW Martinazzi Avenue	34,000
SW Tualatin-Sherwood Road	East of SW Martinazzi Avenue and west of SW Nyberg Road	44,600
SW Nyberg Lane	West of SW Tualatin-Sherwood Road and east of SW Martinazzi Avenue	9,000
SW Nyberg Road	East of SW Tualatin-Sherwood Road and west of I-5 SB Ramp Terminal	51,900
SW Nyberg Road	West of I-5 SB Ramp Terminal and east of I-5 NB Ramp Terminal	38,600
SW Nyberg Road	East of I-5 NB Ramp Terminal and west of SW 65 th Avenue	23,100
SW 65 th Avenue	South of SW Nyberg Road	17,500
SW Borland Road	East of SW 65 th Avenue	14,900
SW 65 th Avenue	South of SW Sagert Street	9,600
SW Sagert Street	West of SW 65 th Avenue	11,500
SW Sagert Street	East of SW Martinazzi Avenue	11,200

SAFETY ANALYSIS

This section provides analysis of roadway safety information within the site vicinity. Three sources of crash data were considered: the ODOT Safety Priority Index System, the Washington County Safety Priority Indexing System (SPIS), and review of crash data provided by ODOT. The ODOT crash data includes all reported crashes that occurred at the study intersections for the three-year period from January 1, 2009 to December 31, 2011 (matching the Tualatin TSP Update review period).

ODOT Statewide Priority Index System

The Statewide Priority Index System (ODOT SPIS) is a method developed by ODOT for identifying hazardous locations on state highways through consideration of crash frequency, crash rate, and crash severity. The ODOT SPIS designates a roadway segment as a SPIS site if a location experiences three or more crashes or one or more fatal crashes over a three-year period. Under this method, all state highways are analyzed in 0.10 mile segments to identify SPIS sites. Statewide, there are approximately 6,000 SPIS sites. SPIS sites are typically intersections, but can also be roadway segments.

Within the study area, none of the ODOT controlled intersections or roadway segments are included in ODOT's SPIS ranking program for 2009-2011.

Washington County Safety Priority Index System (SPIS)

Washington County ranks their high accident SPIS locations based on a formula that identifies potentially hazardous locations. The formula takes into consideration the frequency, rate, and severity of crashes.

Within the study area, there are two intersections that rank within the top 50 SPIS locations. These include SW Tualatin-Sherwood Road/SW Boones Ferry Road and SW Tualatin-Sherwood Road/SW Martinazzi Avenue.

Intersection Crash Data Analysis

The individual crash history of the study intersections was reviewed in an effort to identify potential intersection safety issues. The crash types and crash rates from the analysis are presented in Table 4. Typically, crash rates that meet or exceed 1.0 crashes per million entering vehicles are reviewed for additional geometric and operational investigation. As shown in the table, all of the reported intersections have crash rates less than 1.0. These findings are generally consistent with the crash assessment provided in the Tualatin TSP Update.

Table 4: Intersection Crash History (January 1, 2009 through December 31, 2011)

Intersection	Collision Type						Total Crashes	Estimated Annual Average Daily Traffic	Crash Rate (crashes per million entering vehicles)
	Angle	Turning	Rear End	Fixed Object	Ped / Bike	Other			
SW Upper Boones Ferry Road/ SW Lower Boones Ferry Road/ SW Boones Ferry Road	-	1	-	1	-	-	2	22,300	0.08
SW Boones Ferry Road/ SW Tualatin Road	-	-	4	-	2	-	6	24,800	0.22
SW Boones Ferry Road/ SW Martinazzi Avenue	-	-	4	-	-	-	4	28,300	0.13
SW Nyberg Road/ SW Martinazzi Avenue	-	4	4	-	-	-	8	16,950	0.43
SW Nyberg Road/ SW Tualatin-Sherwood Road	-	8	7	1	-	-	16	44,650	0.33
I-5 SB Ramp Terminal/ SW Nyberg Road	1	20	24	-	2	1	48	50,900	0.86
I-5 NB Ramp Terminal/ SW Nyberg Road	-	6	9	-	-	-	15	40,500	0.34
SW Nyberg Road/ SW 65 th Avenue	-	1	2	-	-	-	3	21,300	0.13
SW Tualatin-Sherwood Road/ SW Boones Ferry Road	3	11	21	-	-	4	39	38,750	0.92
SW Tualatin-Sherwood Road/ SW Martinazzi Avenue	6	2	8	1	-	-	17	42,800	0.36
SW 65 th Avenue/ SW Borland Road	-	1	1	-	-	-	2	20,750	0.09
SW Boones Ferry Road/ SW Sagert Street	-	3	2	-	-	-	5	18,600	0.25
SW Sagert Street/ SW Martinazzi Avenue	4	-	-	-	-	-	4	17,500	0.21
SW Sagert Street/ SW 65 th Avenue	-	-	-	-	-	-	0	15,750	0.00

Section 4
Transportation Impact Analysis

TRANSPORTATION IMPACT ANALYSIS

The transportation impact analysis identifies how the study area’s transportation system will operate in the year the proposed redevelopment is expected to be fully built and occupied (2014). The impact of traffic generated by the proposed Nyberg Rivers development during the typical weekday p.m. and Saturday midday peak hours was examined as follows:

- Background weekday p.m. and Saturday midday peak hour traffic conditions for the 2014 (build-out year of the Nyberg Rivers redevelopment) was analyzed at each of the study intersections.
- Background conditions were developed by applying a 1.5-percent annual growth rate to the existing traffic volumes to account for regional growth in the site vicinity between years 2012 and 2014.
- Site-generated trips were estimated for build-out of the site.
- Site trip-distribution patterns were derived from a review of existing traffic patterns and regional planning model outputs.
- Year 2014 (build-out year of the Nyberg Rivers redevelopment) total traffic conditions were analyzed at each of the study intersections and site-access points during the weekday p.m. and Saturday midday peak hours.
- On-site circulation issues and site-access alternatives were evaluated.

YEAR 2014 BACKGROUND TRAFFIC CONDITIONS

The year 2014 background traffic analysis identifies how the study area’s transportation system will operate without the proposed Nyberg Rivers redevelopment. This analysis includes traffic attributed to general growth in the region, but does not include traffic from the proposed redevelopment.

Traffic Volumes

In order to develop a near-term traffic growth rate, the last five years of annual Washington County daily traffic counts were reviewed along SW Tualatin-Sherwood Road (just east of SW Boones Ferry Road) and SW Nyberg Road (west of SW 65th Avenue). A summary of these counts is provided in Table 5 below.

Table 5: Historical Traffic Counts

Count Location	2008	2009	2010	2011	2012
SW Nyberg Road (west of SW 65 th Avenue)	21,837	20,764	21,733	21,506	21,351
SW Tualatin-Sherwood Road (east of SW Boones Ferry Road)	40,469	38,813	39,671	41,137	40,591

As shown in the table, traffic growth within the general site vicinity between 2008 and 2012 has been minimal to negative, in part reflecting the economic slowdown that occurred after 2008. City staff recommended a 1.5% annual growth rate be applied to reflect a reasonable, yet conservative approximation of traffic growth at each of the study intersections. This growth rate is consistent with other traffic studies that have been submitted in the past within the project vicinity. Figures 5a and 5b illustrate the resulting forecast year 2014 background traffic volumes during the weekday p.m. and Saturday midday peak hours.

2014 Background Operations Analysis

The weekday p.m. and Saturday midday peak-hour turning-movement volumes shown in Figure 5a and 5b were used to conduct an operational analysis at each study intersection to determine the year 2014 background traffic levels of service. As indicated by the respective figures and Table 6, the background traffic analysis determined that all of but two of the study intersections are forecast to operate at acceptable standards during both the weekday p.m. and Saturday midday peak hours. *Appendix "E" contains the year 2014 background traffic level-of-service worksheets.*

SW 65th Avenue/SW Sagert Street

Based on the estimated future traffic demand, the intersection is forecast to continue to operate at LOS F conditions during the weekday p.m. peak hour.

SW Martinazzi Avenue/SW Sagert Road

Based on the existing traffic demand, the intersection is forecast to continue to operate at LOS F conditions during the weekday p.m. peak hour.

H:\projects\12116 - K-Mer Tualatin Redevelopment\figs\April2013\12116_Fig01.dwg Apr 16, 2013 - 2:38pm - mhughart Layout Tab: Fig05A

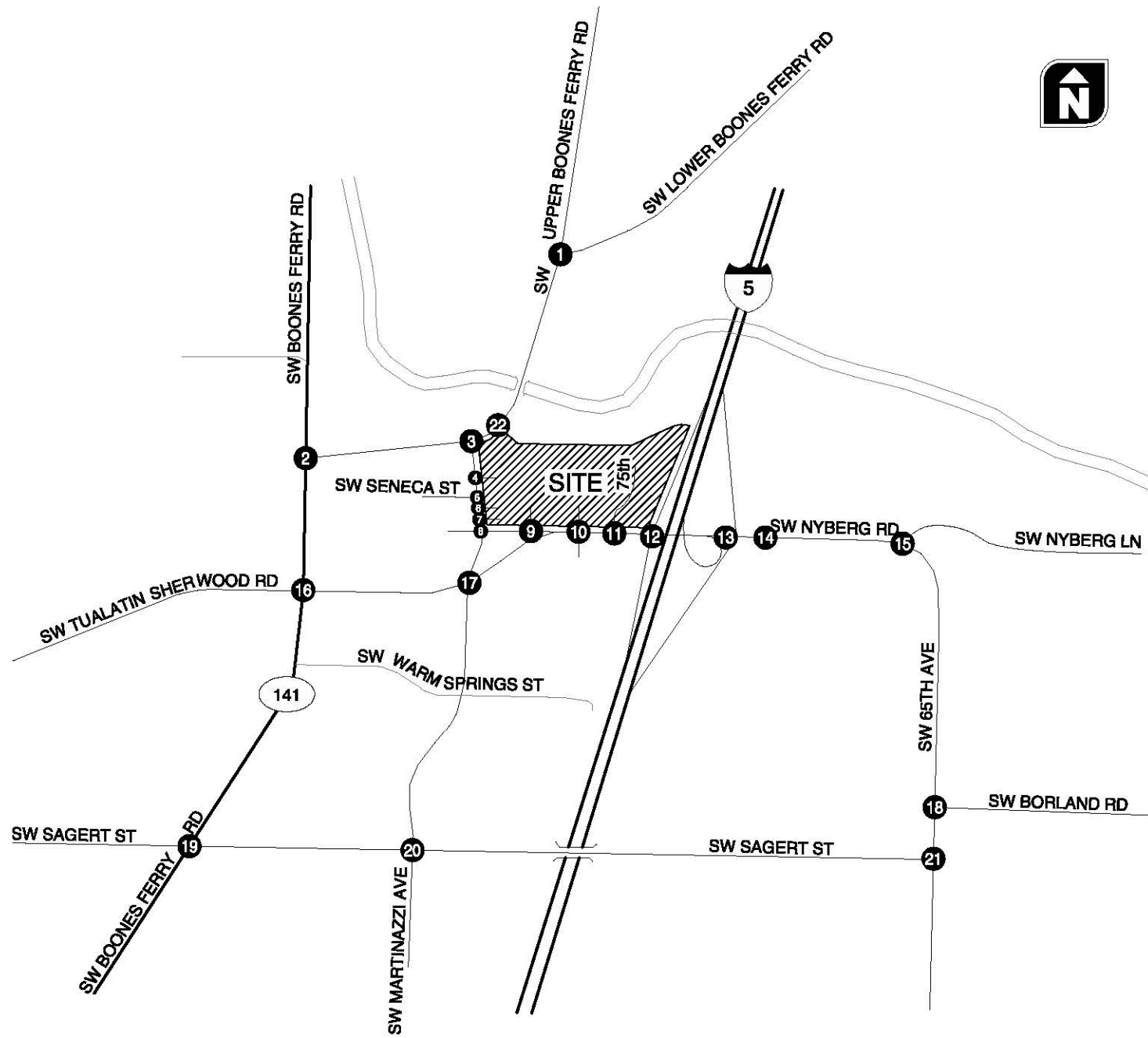

LEGEND

- CM = CRITICAL MOVEMENT (TWSC)
- LOS = INTERSECTION LEVEL OF SERVICE (SIGNALIZED/AWSC)/CRITICAL MOVEMENT LEVEL OF SERVICE (TWSC)
- Del = INTERSECTION AVERAGE CONTROL DELAY (SIGNALIZED/AWSC) / CRITICAL MOVEMENT CONTROL DELAY (TWSC)
- V/C = CRITICAL VOLUME-TO-CAPACITY RATIO
- TWSC = TWO-WAY STOP CONTROL
- AWSC = ALL-WAY STOP CONTROL

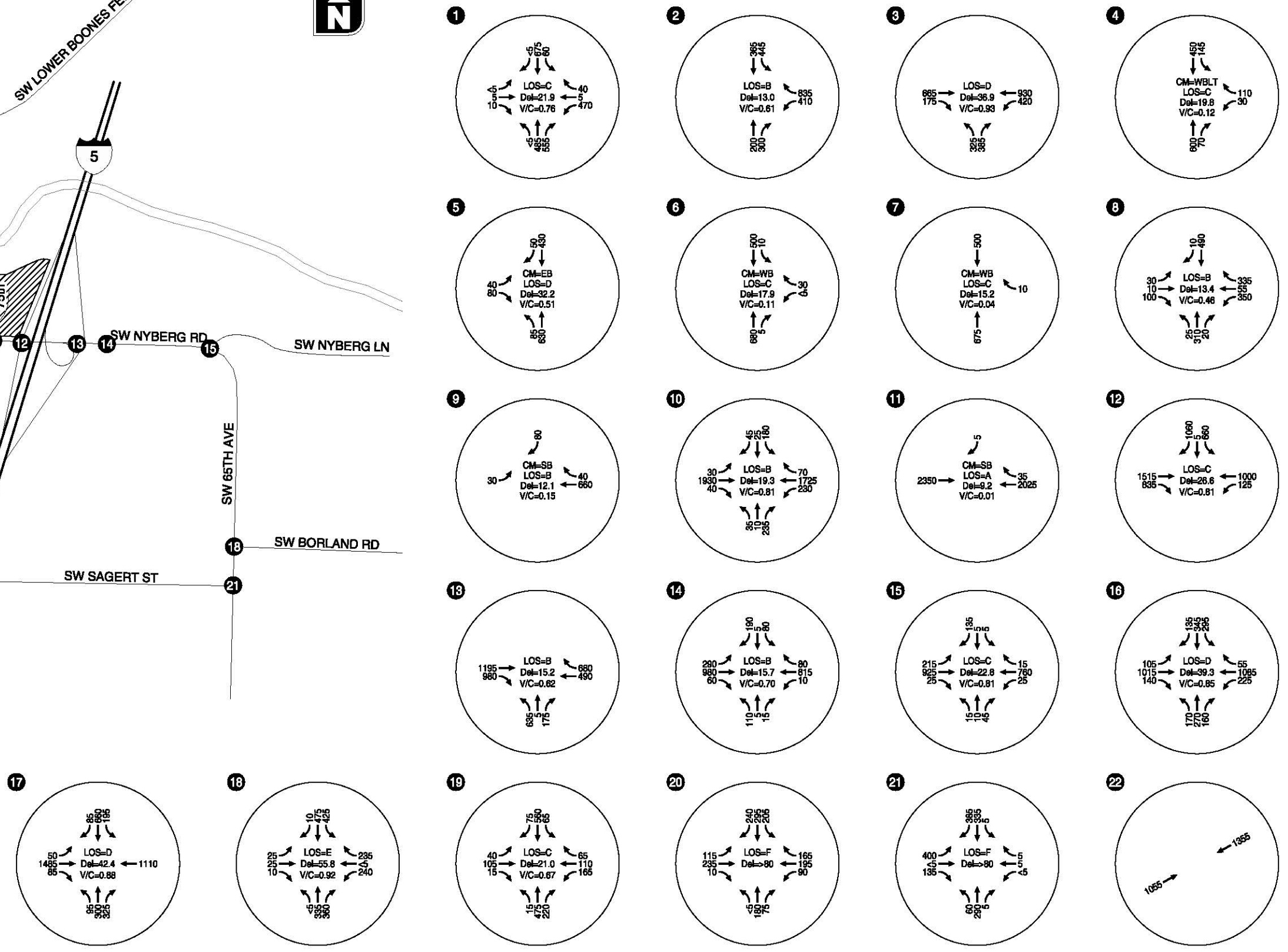

2014 BACKGROUND TRAFFIC CONDITIONS, WEEKDAY PM PEAK HOUR TUALATIN, OREGON

FIGURE 5A

H:\projects\12116 - K-Mer Tualatin Redevelopment\figs\April2013\12116_Fig01.dwg Apr 17, 2013 - 12:41pm - mhughart Layout Tab: Fig05B

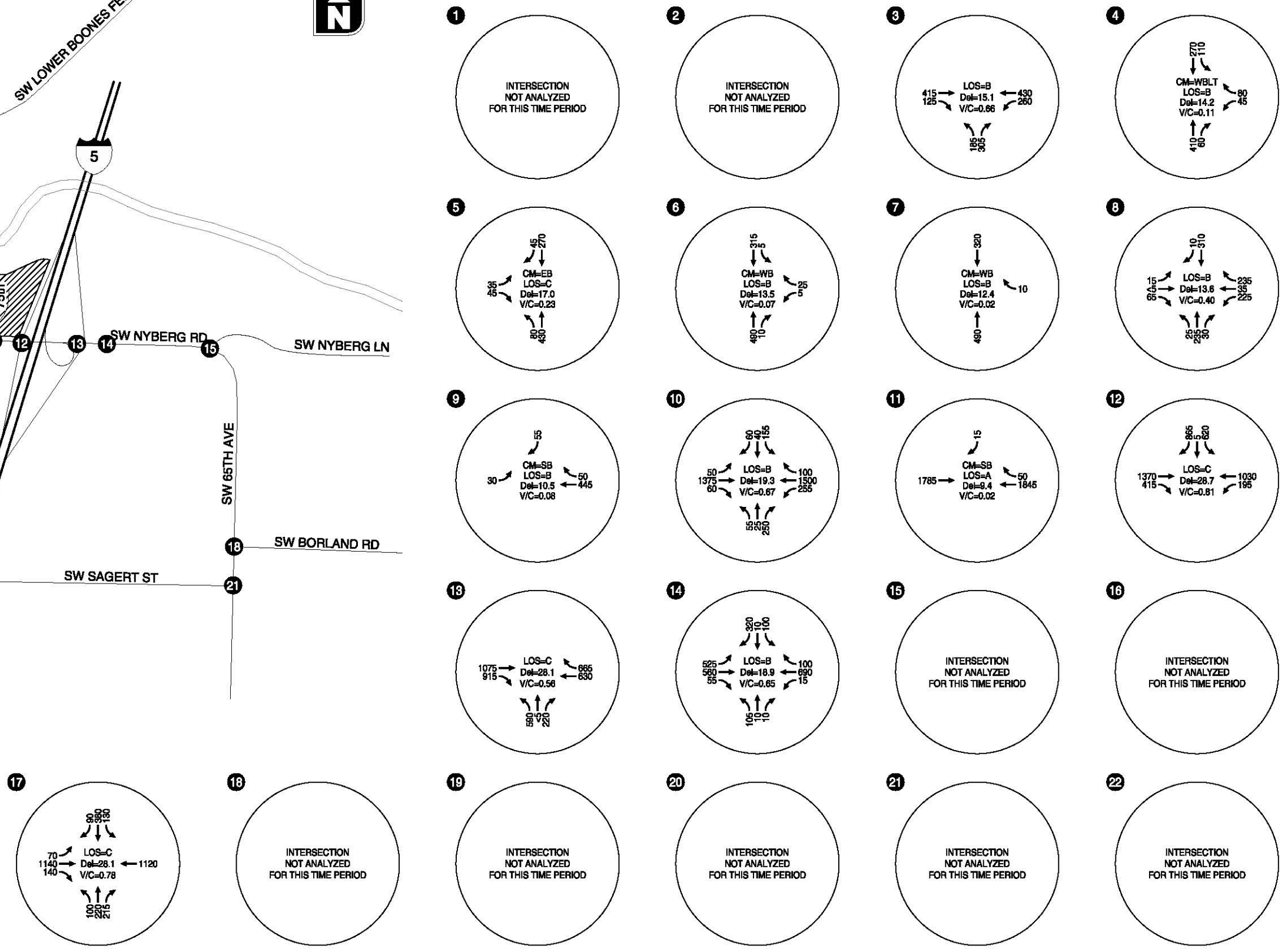
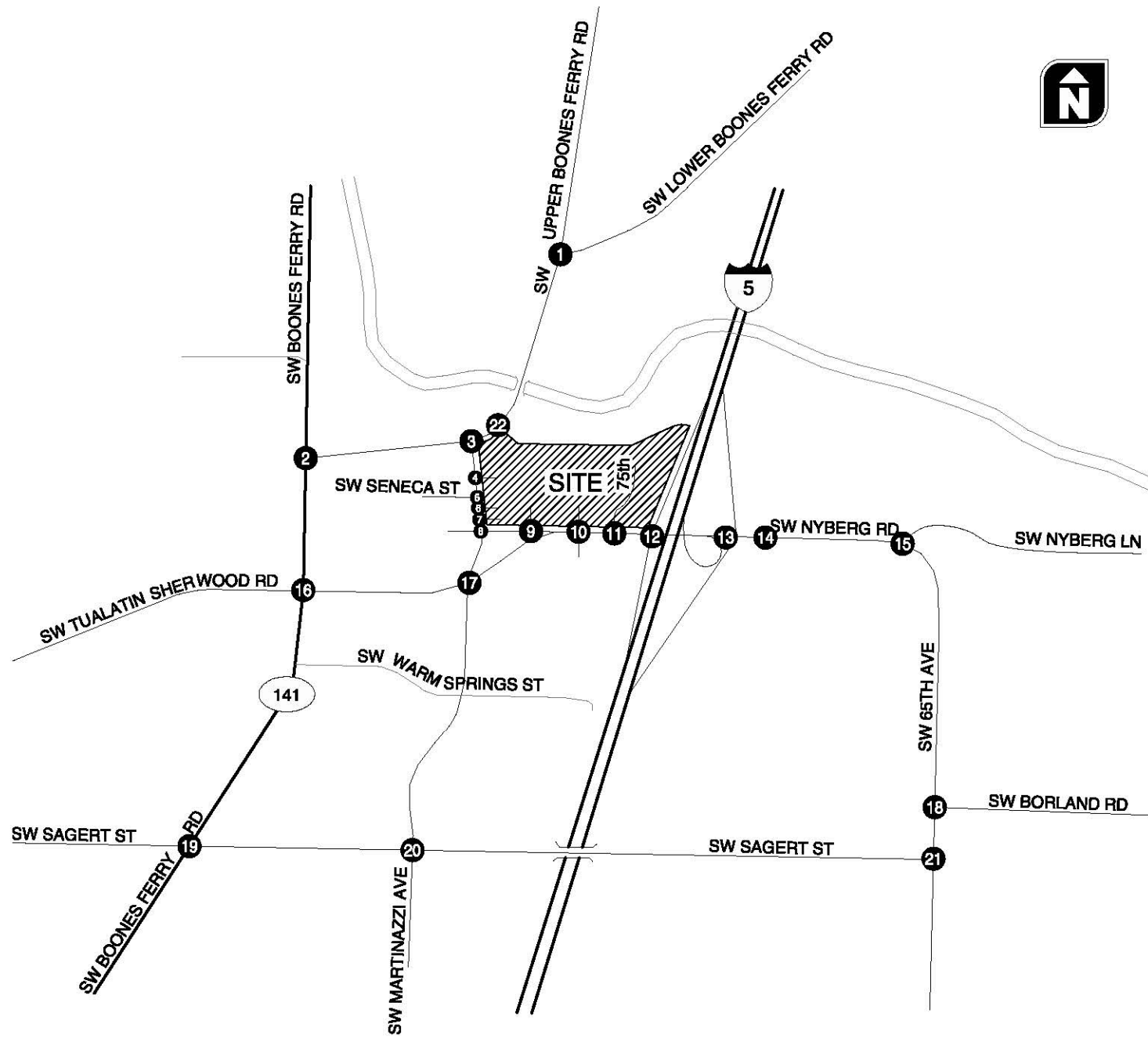

LEGEND

- CM = CRITICAL MOVEMENT (TWSC)
- LOS = INTERSECTION LEVEL OF SERVICE (SIGNALIZED/AWSC)/CRITICAL MOVEMENT LEVEL OF SERVICE (TWSC)
- Del = INTERSECTION AVERAGE CONTROL DELAY (SIGNALIZED/AWSC) / CRITICAL MOVEMENT CONTROL DELAY (TWSC)
- V/C = CRITICAL VOLUME-TO-CAPACITY RATIO
- TWSC = TWO-WAY STOP CONTROL
- AWSC = ALL-WAY STOP CONTROL

2014 BACKGROUND TRAFFIC CONDITIONS, SATURDAY MIDDAY PEAK HOUR TUALATIN, OREGON

FIGURE 5B

Table 6: 2014 Background Traffic Conditions

Number	Intersection	Maximum Operating Standard	Weekday PM Peak Hour		Saturday Midday Peak Hour	
			LOS	V/C	LOS	V/C
Signalized Intersections						
1	SW Upper Boones Ferry Road/ SW Lower Boones Ferry Road/ SW Boones Ferry Road	0.99	C	0.76	Not Analyzed	Not Analyzed
2	SW Boones Ferry Road/ SW Tualatin Road	0.99	B	0.61	Not Analyzed	Not Analyzed
3	SW Boones Ferry Road/ SW Martinazzi Avenue	0.99	D	0.93	B	0.66
8	SW Nyberg Road/ SW Martinazzi Avenue	0.99	B	0.46	B	0.40
10	SW Nyberg Road/ SW Tualatin-Sherwood Road/ Fred Meyer/Site Driveway	0.99	B	0.81	B	0.67
12	I-5 SB Ramp Terminal/ SW Nyberg Road	0.85	C	0.81	C	0.81
13	I-5 NB Ramp Terminal/ SW Nyberg Road	0.85	B	0.62	C	0.56
14	SW Nyberg Road/ Nyberg Woods Driveway	0.99	B	0.70	B	0.65
15	SW Nyberg Road/ SW 65 th Avenue	0.99	C	0.81	Not Analyzed	Not Analyzed
16	SW Tualatin-Sherwood Road/ SW Boones Ferry Road	0.99	D	0.85	Not Analyzed	Not Analyzed
17	SW Tualatin-Sherwood Road/ SW Martinazzi Avenue	0.99	D	0.88	C	0.78
18	SW 65 th Avenue/ SW Borland Road	0.99	E	0.92	Not Analyzed	Not Analyzed
19	SW Boones Ferry Road/ SW Sagert Street	0.99	C	0.67	Not Analyzed	Not Analyzed
Unsignalized Intersections¹						
4	SW Martinazzi Avenue/ North Site Driveway	E	C	0.12	B	0.11
5	SW Martinazzi Avenue/ SW Seneca Street	E	D	0.51	C	0.23
6	SW Martinazzi Avenue/ Site Driveway	E	C	0.11	B	0.07
7	SW Martinazzi Avenue/ Right-Out Only Site Driveway	E	C	0.04	B	0.02
9	SW Nyberg Road/ Site Driveway	E	B	0.15	B	0.08
11	SW Nyberg Road/ Right-in Right-Out Site Driveway	0.99	A	0.01	A	0.02
All-Way Stop-Controlled Intersections						
20	SW Sagert Street/ SW Martinazzi Avenue	D	F	N/A	Not Analyzed	Not Analyzed
21	SW Sagert Street/ SW 65 th Avenue	D	F	N/A	Not Analyzed	Not Analyzed

Notes:

¹ LOS and V/C reported for the highest delay or critical movement

For intersections #4, #5, #6, and #7, it is recognized that the operational results shown may differ slightly due to the presence of vehicle queuing along SW Martinazzi Avenue during peak time periods.

Background Daily Traffic Profile

A summation of the 2014 Background daily traffic volumes and their comparison to 2012 existing conditions is summarized in Table 7 below (the growth shown in Table 7 reflects the assumed 1.5% annual growth).

Table 7: 2014 Background Daily Traffic Profile

Roadway	Segment	Estimated Daily Volume	
		2012 Existing	2014 Background
SW Lower Boones Ferry Road	East of SW Upper Boones Ferry Road	13,200	13,600
SW Boones Ferry Road	East of SW Martinazzi Avenue	28,100	28,800
SW Boones Ferry Road	West of SW Martinazzi Avenue	24,400	25,100
SW Martinazzi Avenue	South of SW Boones Ferry Road and north of SW Nyberg Road	13,700	14,100
SW Martinazzi Avenue	South of SW Tualatin-Sherwood Road	17,100	17,600
SW Boones Ferry Road	North of SW Tualatin-Sherwood Road	14,000	14,500
SW Boones Ferry Road	South of SW Tualatin-Sherwood Road	15,200	15,700
SW Tualatin-Sherwood Road	West of SW Boones Ferry Road	30,800	31,800
SW Tualatin-Sherwood Road	East of SW Boones Ferry Road and west of SW Martinazzi Avenue	34,000	34,900
SW Tualatin-Sherwood Road	East of SW Martinazzi Avenue and west of SW Nyberg Road	36,400	37,400
SW Nyberg Lane	West of SW Tualatin-Sherwood Road and east of SW Martinazzi Avenue	9,000	9,200
SW Nyberg Road	East of SW Tualatin-Sherwood Road and west of I-5 SB Ramp Terminal	51,900	52,900
SW Nyberg Road	West of I-5 SB Ramp Terminal and east of I-5 NB Ramp Terminal	38,600	39,600
SW Nyberg Road	East of I-5 NB Ramp Terminal and west of SW 65 th Avenue	23,100	23,800
SW 65 th Avenue	South of SW Nyberg Road	17,500	18,100
SW Borland Road	East of SW 65 th Avenue	14,900	15,400
SW 65 th Avenue	South of SW Sagert Street	9,600	9,900
SW Sagert Street	West of SW 65 th Avenue	11,500	11,900
SW Sagert Street	East of SW Martinazzi Avenue	11,200	11,600

PROPOSED REDEVELOPMENT PLAN

In an effort to enhance and reinvigorate the existing shopping center, CenterCal is proposing to redevelop a portion of the existing center. The redevelopment is envisioned to entail the following:

- The 96,799 square foot former K-Mart building will be removed.
- The existing 3,500 square foot building currently occupied by a Wendy’s will be relocated to a new pad within the shopping center site.
- All other existing buildings (and associated access driveways) will remain as it has been assumed that the existing tenants will continue to operate as-is for the foreseeable future.
- While a specific tenant mix is still being developed by CenterCal, it is envisioned that the redeveloped portion of the center will include large and medium sized retailers and an assortment of smaller retail/restaurant uses. For the purposes of this traffic study, it has

been assumed that this mix of uses will total approximately 245,456 square feet of new leasable area bringing the total net leasable area for the entire shopping center to 307,000 square feet.

In order to enhance access to the redeveloped shopping center, several modifications to the existing shopping center driveways are proposed. These include the following:

- The existing SW 75th Avenue connection to SW Nyberg Road is proposed to be closed under the redevelopment plan. This closure will minimize turning movement conflicts along a busy segment of SW Nyberg Road and it will improve the interchange access spacing conditions within the I-5/Nyberg Interchange influence area.
- The existing signalized access on SW Nyberg Road that serves the shopping center and the adjacent Fred Meyer site will remain at its current location; however, the following changes are proposed to increase intersection capacity:
 - A westbound right-turn lane is proposed on SW Nyberg Street to enhance access to the site and minimize vehicle queuing on SW Nyberg Street.
 - The existing site driveway is proposed to be widened as shown in the site plan to accommodate increased site traffic. This widening will include dual southbound left-turn lanes, a shared through/right-turn lane, and dual in-bound receiving lanes (See the *"Impacts of the Nyberg Rivers Development on Identified Transportation Planning Projects"* section for further discussion on these improvements).
 - The north and south approach signal phasing is proposed to be modified from permissive left-turn phasing to split phasing. Westbound right-turn overlap phasing is proposed for the westbound right-turn lane into the Nyberg Rivers site.
 - No modifications are proposed to the existing Fred Meyer driveway at this intersection.

Figure 6 shows the proposed site-access configurations and traffic control devices that will be assumed as part of the total traffic analysis. Construction of this development is expected to begin in 2013 with the build-out projected to occur in year 2014.

H:\proj\12116 - K-Merit Tualatin Redevelopment\chgs\Apr12\201312116_Fig01.dwg Apr 15, 2013 - 4:10pm - mhughart Layout Tab: Fig06

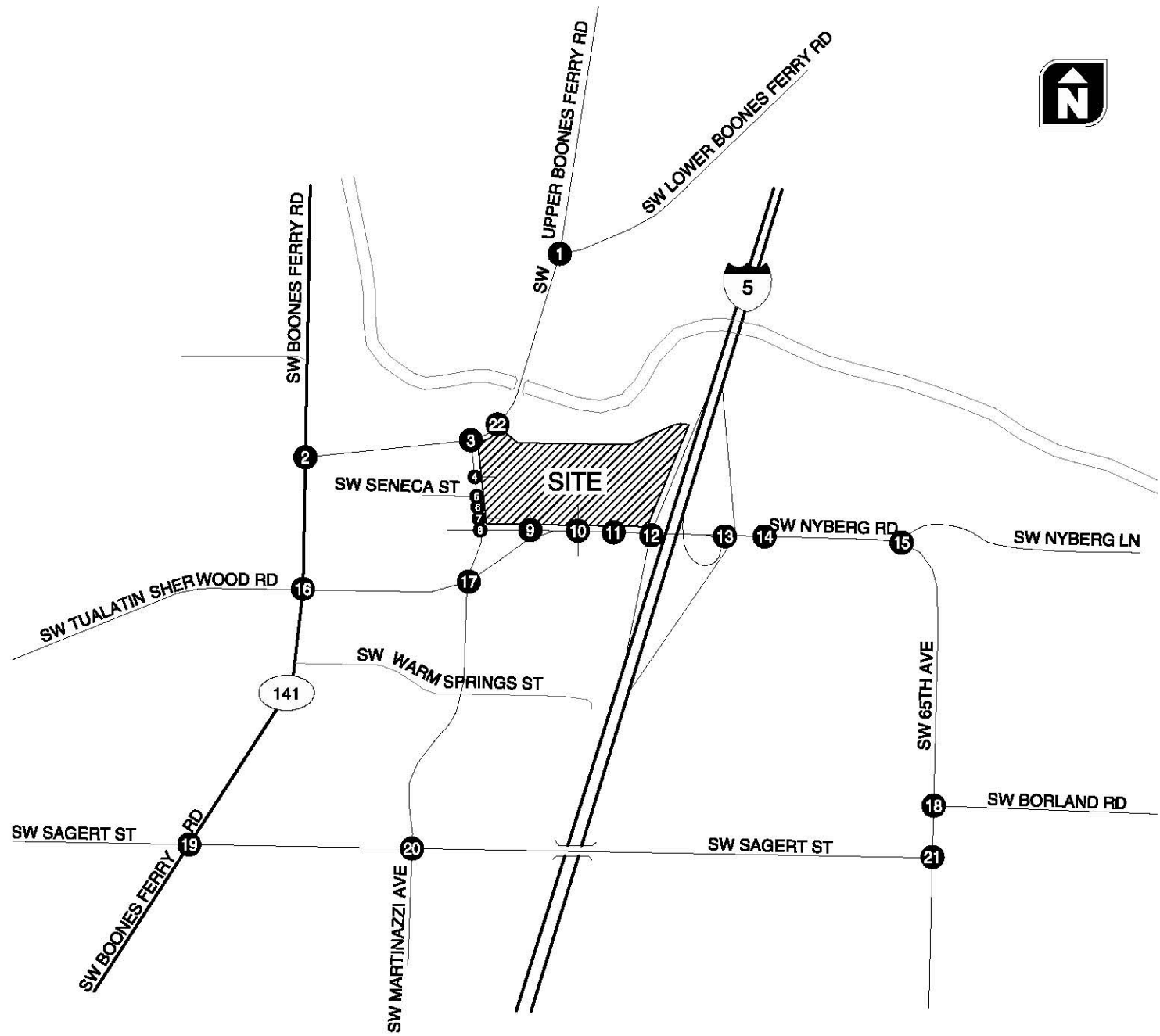

LEGEND

- NEW TRAVEL LANE
- STOP SIGN
- TRAFFIC SIGNAL

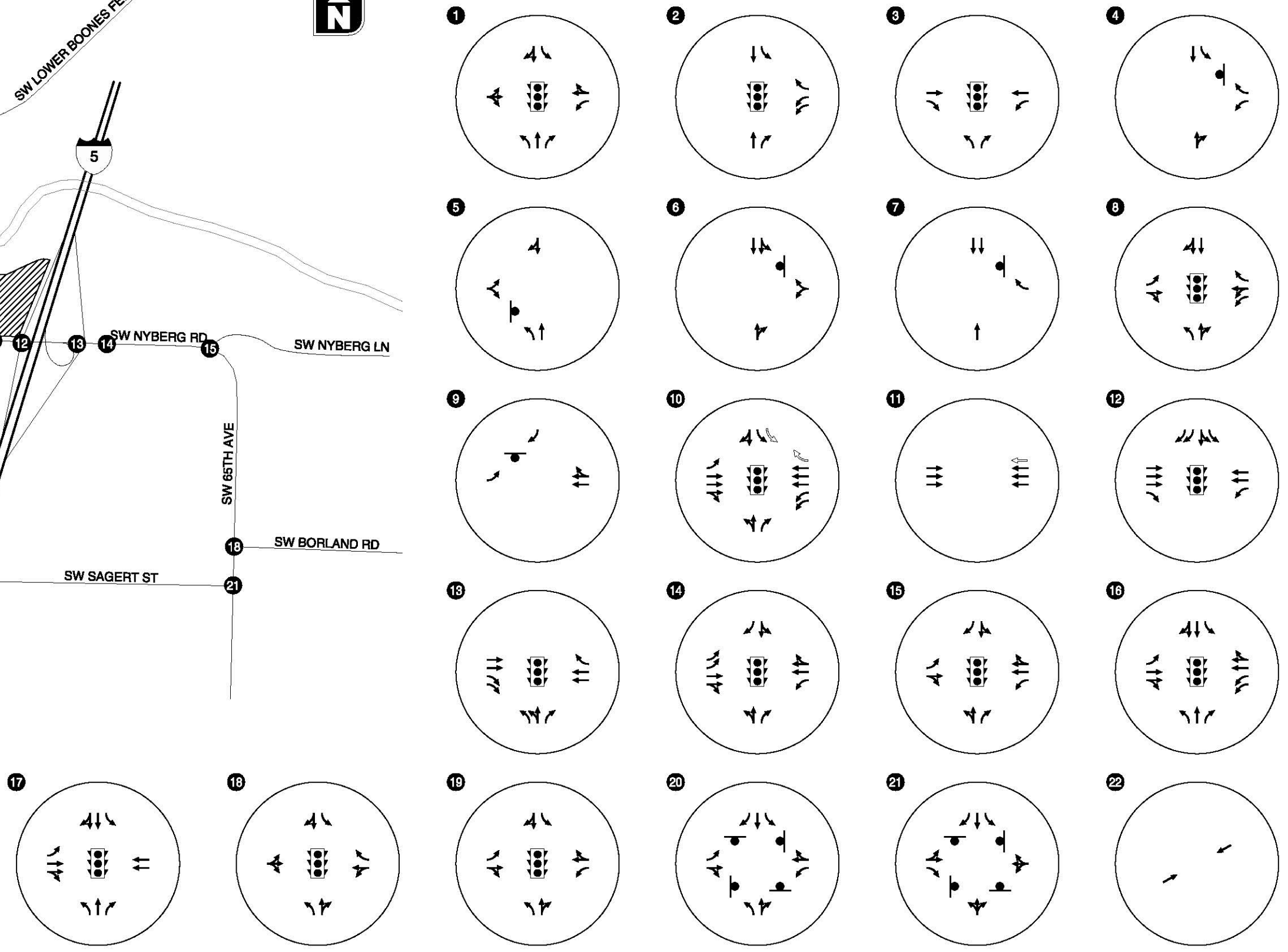

ASSUMED SITE ACCESS CONFIGURATION AND TRAFFIC CONTROL DEVICES TUALATIN, OREGON

FIGURE 6

Redevelopment Plan Trip Generation

Given that the proposed project is only a partial redevelopment of the larger shopping center; a trip generation methodology was developed to reflect the characteristics of a unified and vibrant shopping center. The following outline describes the trip generation methodology that was used:

- Traffic counts were conducted at all of the site driveways to quantify the trip generation profile of the existing retail and civic uses currently operating on the site.
- Recognizing that the City offices/library are not retail uses and the layout of the site/parking fields prevents an accurate quantification of trips being generated by these uses, estimates were developed using the standard reference manual, *Trip Generation*, published by the Institute of Transportation Engineers (ITE). The Library and Single Tenant Office Building land uses were used in the estimate process. The resulting estimates were then subtracted from the existing site driveway counts to produce a trip profile estimate for the existing 158,343 square feet of retail building space at the site.
- A trip generation rate was calculated using the Shopping Center land use in ITE *Trip Generation* for the 245,456² square feet of new retail use plus the 61,544 square feet of remaining retail uses³.
- The existing site retail traffic estimate was then subtracted from the total shopping center and office trip generation estimate to arrive at a total trip estimate for the net increase in shopping center and office square footage. A pass-by rate reduction of 34%⁴ was assumed for the shopping center component to generate the net new trip estimate for the site. This pass-by estimate is consistent with ITE *Trip Generation* for similar shopping center uses. Furthermore, given the mix of existing uses (fast-food restaurants, drive-thru banks, and shopping center commercial uses) that will remain on the site and proposed mix of uses (large and medium sized general retailers and assortment of general retail/restaurant uses), this pass-by reduction rate is considered to be reasonable and conservatively appropriate.

² New Retail Uses = Total Proposed Area – Existing Uses that Remain = 307,000 sq. ft. – 61,544 sq. ft. = 245,456 sq. ft.

³ Remaining uses = Existing building area – Existing Kmart = 158,343 sq. ft. - 96,799 sq. ft. = 61,544 sq. ft.)

⁴ There are approximately 55,000-60,000 vehicles per day passing by the site frontage on SW Tualatin-Sherwood Road and SW Martinazzi Avenue. This volume is considered sufficient to justify the standard 34 percent pass-by assumption for the shopping center (the average 34 percent was obtained directly from the Institute of Transportation Engineers (ITE) *Trip Generation*, 9th Edition). It is also expected that some trips will re-route from I-5, which would be considered “diverted trips”. All trips coming from I-5 were considered “primary” trips in an effort to present a conservative and reasonable worst-case condition. ITE *Trip Generation* Shopping Center trip rates indicate that an average 26 percent of shopping center trips are diverted, in addition to the 34 percent pass-by. By not accounting for diverted trips, the current study is inherently conservative and likely overstates impacts between the main site driveway and the I-5 interchange ramps.

Table 8 below illustrates the trip generation calculation process (all trip ends shown in Table 8 have been rounded to the nearest five trips).

Table 8: Estimated Nyberg Rivers Trip Generation

	ITE Code	Size (sq. ft.)	Weekday PM Peak Hour			Saturday Midday Peak Hour		
			Total	In	Out	Total	In	Out
Existing Site								
Existing Site Driveways ¹	-	-	945	435	510	970	490	480
Less Existing Library ²	590	22,123	(160)	(75)	(85)	(150)	(80)	(70)
Less Existing Civic Uses ³	715	~10,000	(50)	(10)	(40)	-	-	-
Total Existing Retail			735	350	385	820	410	410
Future Site								
Shopping Center	820	307,000 ⁴	1,350	660	690	1,775	925	850
<i>Less Existing Retail Driveway Counts</i>			(735)	(350)	(385)	(820)	(410)	(410)
Sub Total			615	310	305	955	515	440
<i>Pass-by Trips (Weekday 34%, Saturday 26%)</i>			(210)	(105)	(105)	(230)	(115)	(115)
Net New Trips			405	205	200	725	400	325

¹Represents the total site driveway counts during the weekday p.m. peak hour of 4:35-5:35 p.m. and Saturday midday peak hour of 12:10-1:10 p.m. This is the traffic volume being generated by the existing 158,343 square feet of shopping center currently residing on the site prior to Kmart’s closure.

²The library traffic counts were estimated using the *Library* land use in *ITE Trip Generation*.

³The City Hall traffic counts were estimated using the *Single Tenant Office Building* land use in *ITE Trip Generation*. The existing City Hall square footage was estimated to be approximately 10,000 square feet in size.

⁴Includes the 158,343 square feet of existing shopping center (minus the 96,799 square foot former K-Mart) plus the 245,456 square feet of proposed shopping center uses.

As shown in Table 8, the proposed redevelopment project is anticipated to generate approximately 405 net new weekday p.m. peak hour trips and 725 net new Saturday midday peak hour trips.

Site Trip Distribution/Trip Assignment

The trip distribution pattern for the proposed redevelopment project was estimated based on a review of existing traffic patterns and a select zone assignment obtained from Washington County’s travel demand model. A *summary output sheet from the travel demand model and the distribution calculations derived from it is provided in the first part of Appendix F*. The trip distribution pattern used in the analysis is shown in Figure 7.



H:\profile\12116 - K-Mart Tualatin Redevelopment\dwgs\figs\April2013\12116_Fig01.dwg Apr 15, 2013 - 4:10pm - mhughart Layout Tab: Fig07

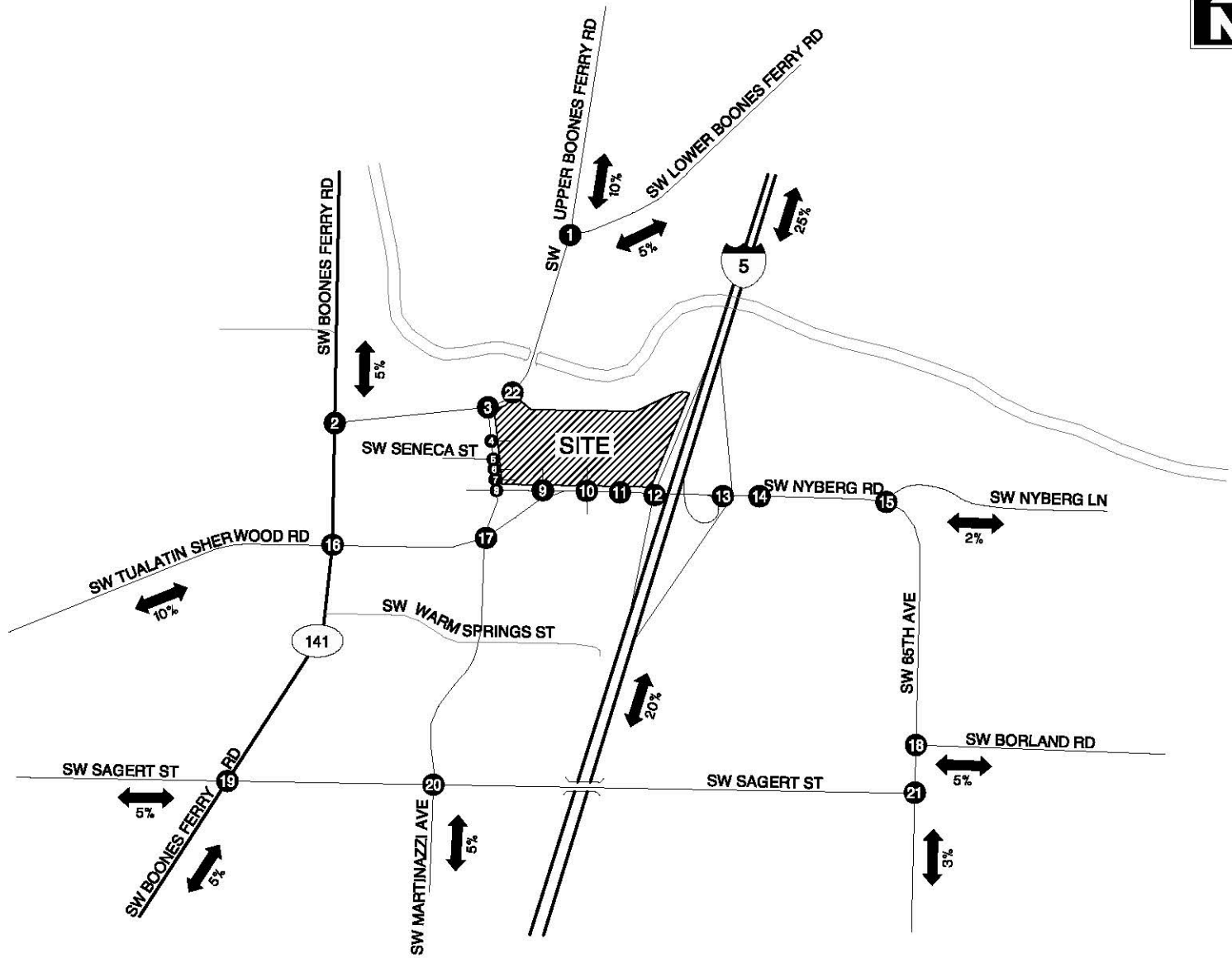

ESTIMATED TRIP DISTRIBUTION PATTERN
TUALATIN, OREGON

FIGURE
7

The estimated site-generated trips were assigned to the network by distributing the trips shown in Table 8 according to the trip distribution pattern shown in Figure 7. Figures 8aA/8aPB and 8bA/8bBP illustrate the site-generated/pass-by trips that are expected to use the roadway system during the weekday p.m. and Saturday midday peak hours.

YEAR 2014 TOTAL TRAFFIC CONDITIONS

The total traffic conditions analysis forecasts how the study area's transportation system will operate with the traffic generated by the Nyberg Rivers redevelopment plan. The year 2014 background traffic volumes for the weekday p.m. and Saturday midday peak hours (shown in Figure 5a and 5b) were added to the site-generated traffic (shown in Figures 8aA/8aPB and 8bA/8bPB) to arrive at the total traffic volumes that are shown in Figures 9a and 9b.

2014 Total Traffic Operations

The weekday p.m. and Saturday midday peak hour turning-movement volumes shown in Figures 9a and 9b were used to conduct an operational analysis at each study intersection and site driveway to determine the year 2014 total traffic operations. The results of the total traffic analysis shown in Figures 9a, 9b, and Table 9 indicate that all of the study intersections and site access points, except for the SW 65th Avenue/SW Sager Road and SW Martinazzi Avenue/SW Sagert Road intersections, are forecast to operate at acceptable operations during the weekday p.m. and Saturday midday peak hours. *Appendix "F" contains the year 2014 total traffic level-of-service worksheets.*

The SW Martinazzi Avenue/SW Sagert Road and SW 65th Avenue/SW Sagert Road intersections are forecast to continue to operate at LOS F. The proposed development is estimated to contribute an additional 1.6% and 0.6%, respectively, during the weekday p.m. peak hour. Given this small increase, no development-driven traffic mitigation is recommended for the following reasons:

- The Tualatin TSP has identified mitigations for these two intersections that, when implemented, will address the long-term operations.
- The Washington County Transportation Development Tax (TDT) in part funds an improvement project on SW Sagert Street that will add capacity and reduce delay to both intersections.

H:\proj\12116 - K-Merit Tualatin Redevelopment\chgs\Apr12\201312116_Fig01.dwg Apr 15, 2013 - 4:17pm - mhughart Layout Tab: Fig08aA

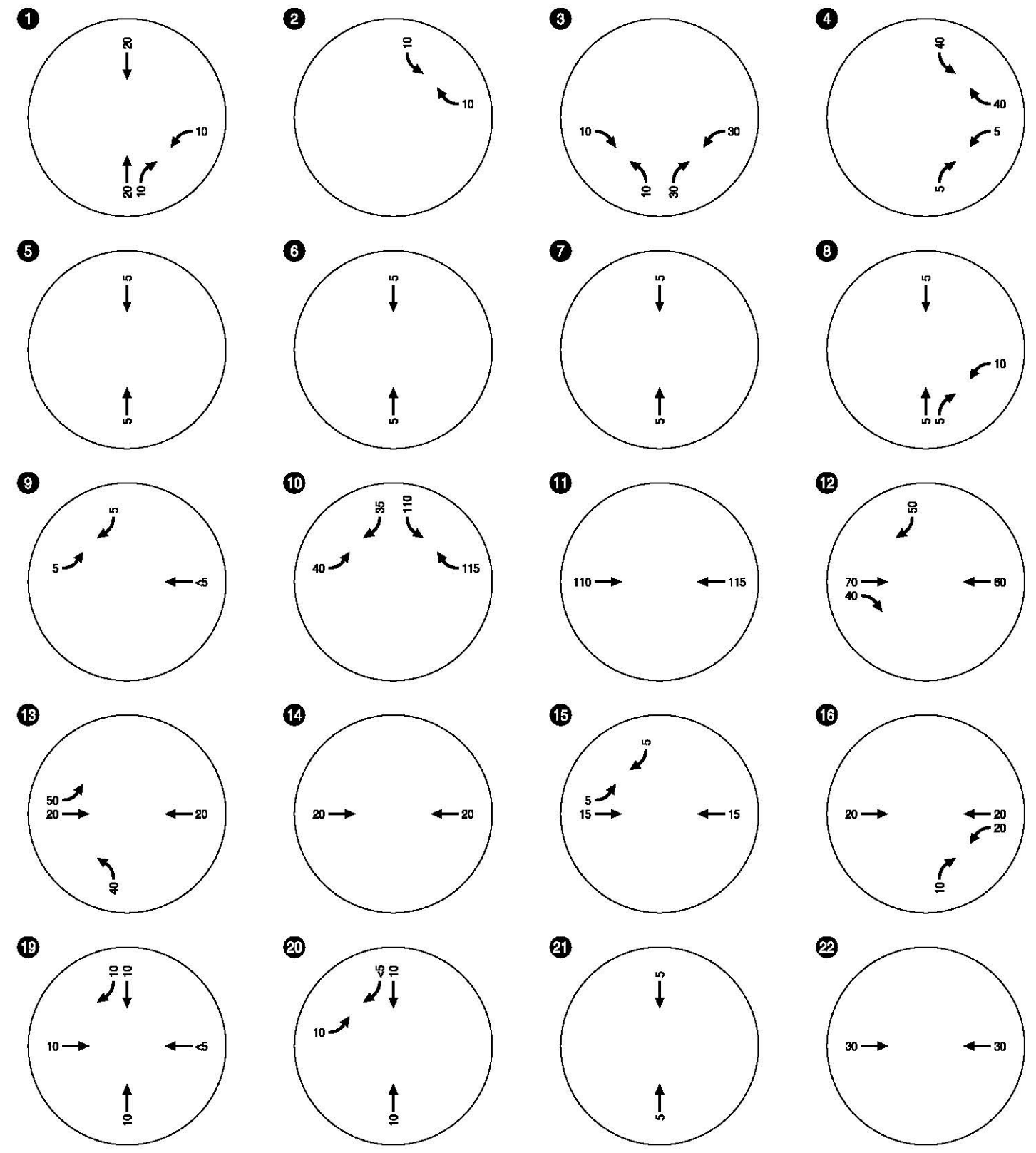
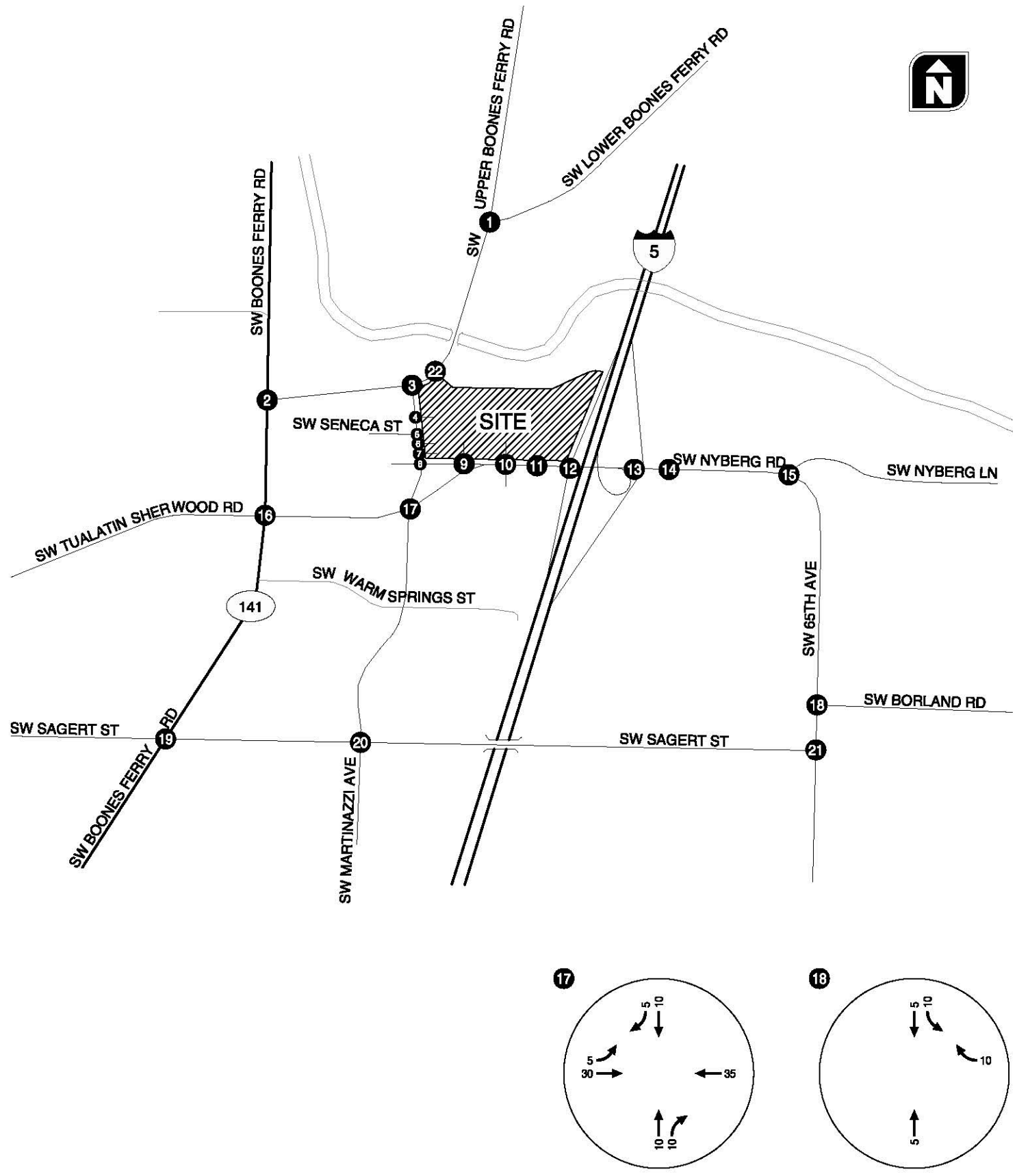

SITE-GENERATED TRIPS (ADDED TRIPS), WEEKDAY PM PEAK HOUR
ASSUMED SITE ACCESS CONFIGURATION
TUALATIN, OREGON

FIGURE
8aA

H:\projects\12116 - K-Merit Tualatin Redevelopment\chgs\figs\April2013\12116_Fig01.dwg Apr 15, 2013 4:12pm - mhughart Layout Tab: Fig08aPB

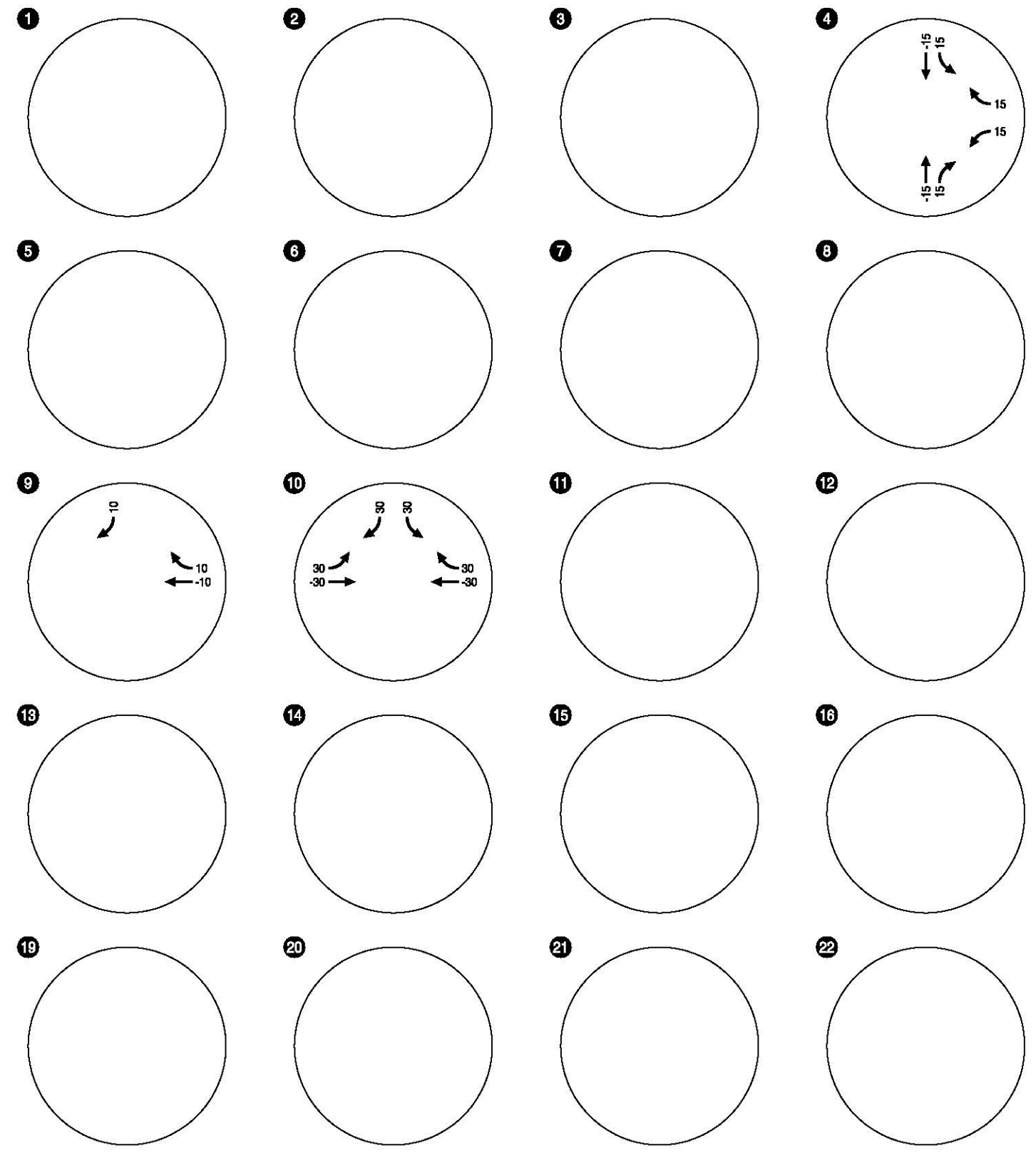
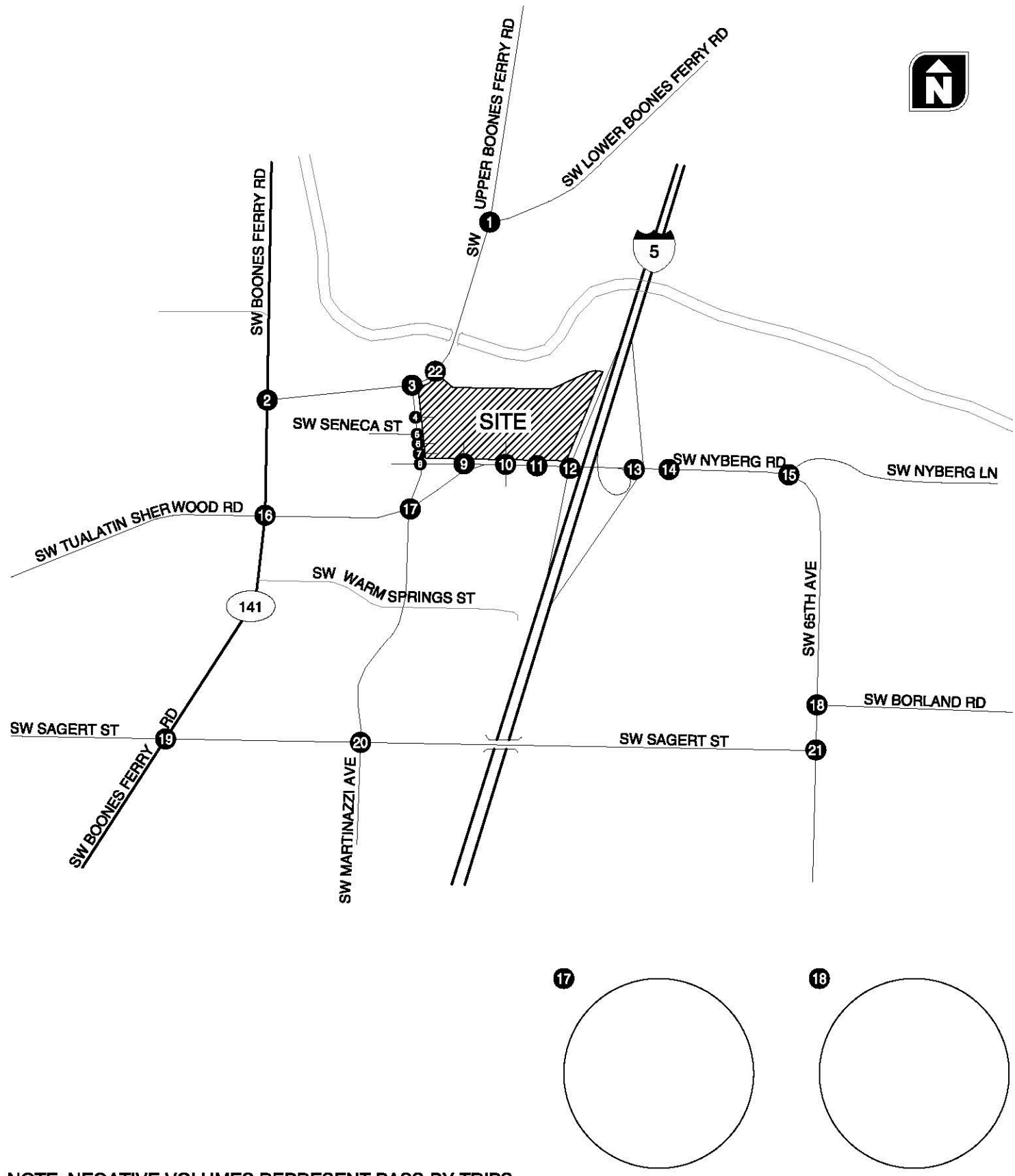

NOTE: NEGATIVE VOLUMES REPRESENT PASS-BY TRIPS

SITE-GENERATED TRIPS (PASS BY TRIPS), WEEKDAY PM PEAK HOUR
ASSUMED SITE ACCESS CONFIGURATION
TUALATIN, OREGON

FIGURE
8aPB

H:\proj\12116 - K-Merit Tualatin Redevelopment\chgs\lgs\April\2013\12116_Fig01.dwg Apr 15, 2013 - 4:12pm - mhughart Layout Tab: Fig08bA

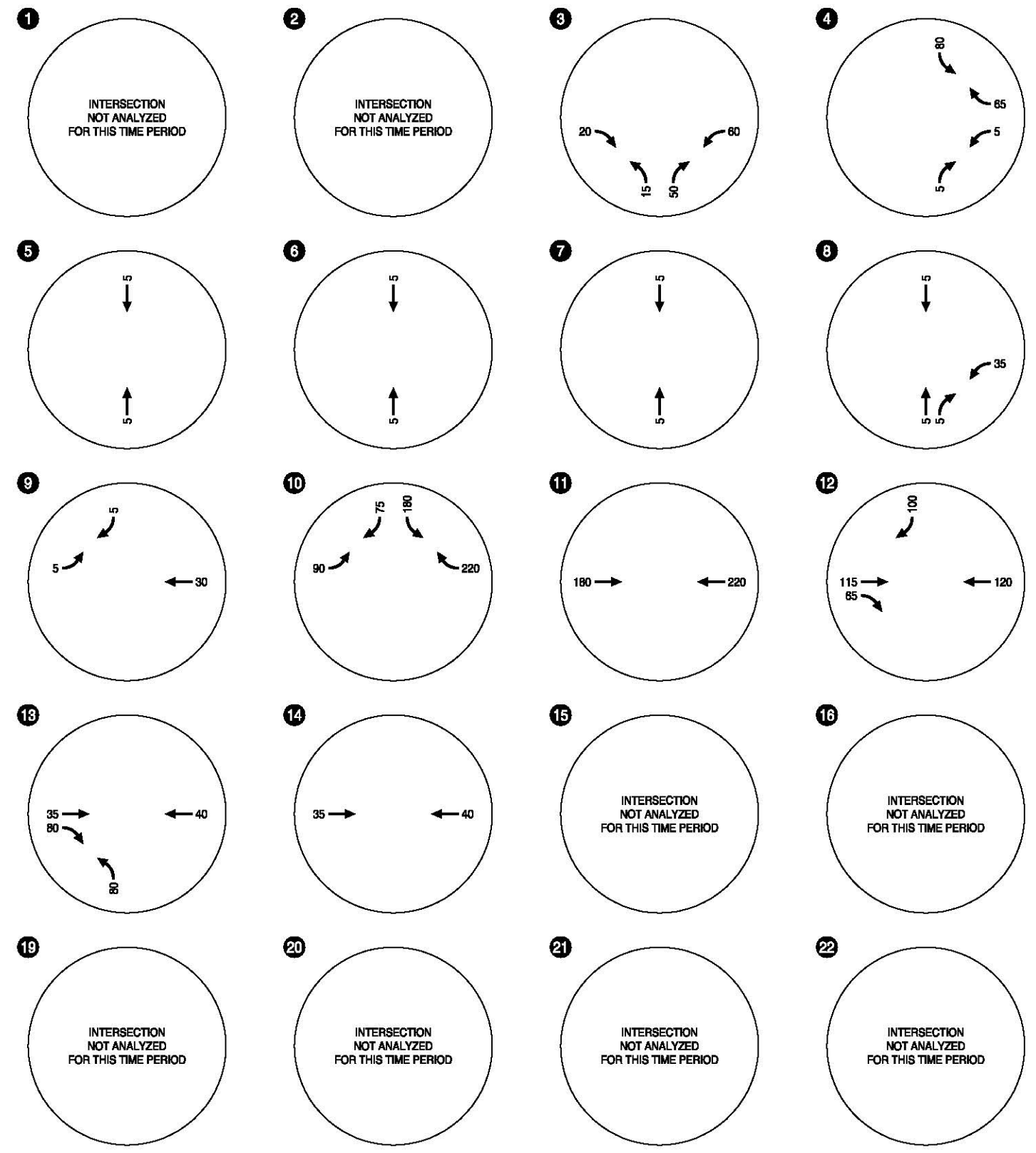
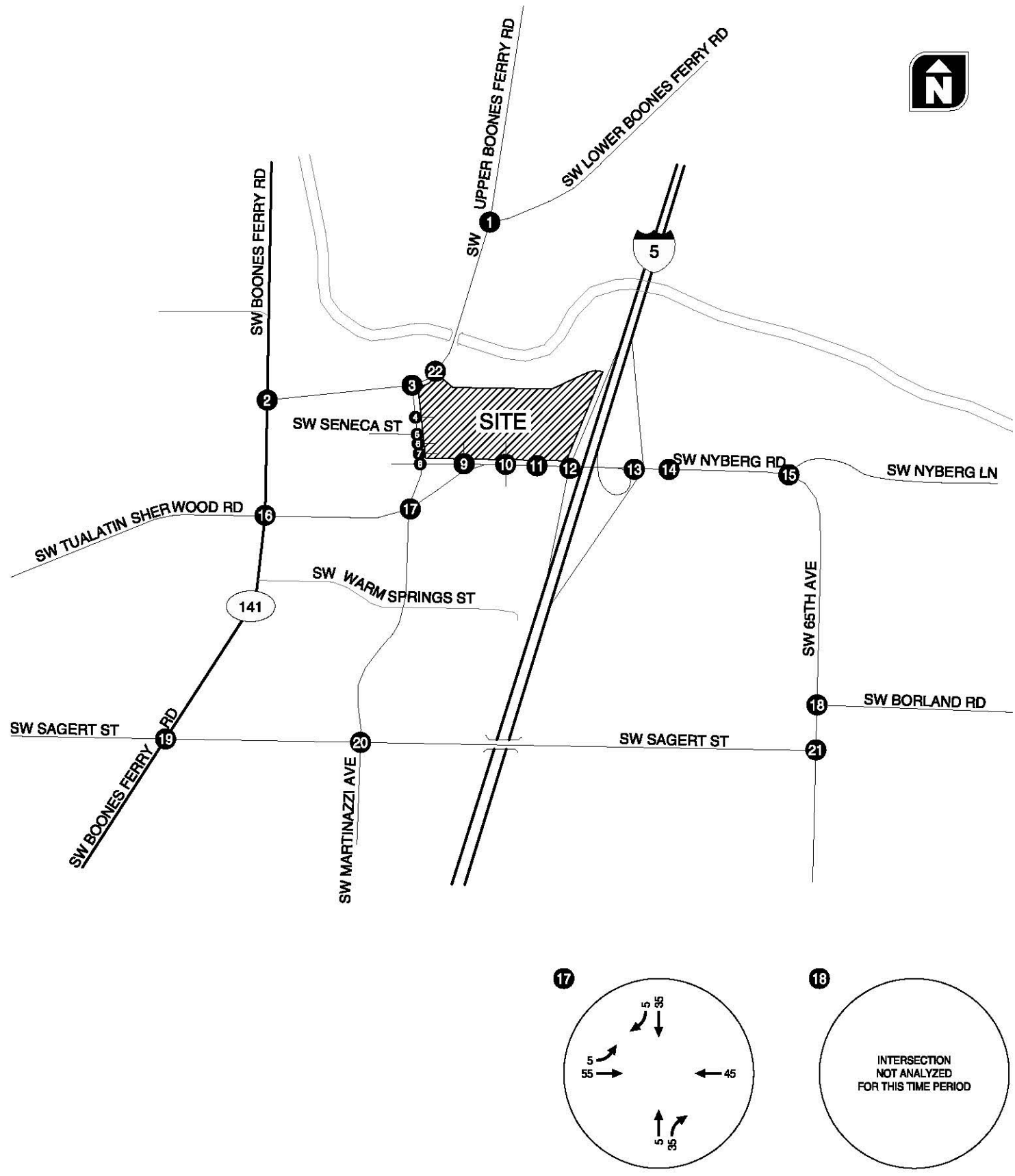

SITE-GENERATED TRIPS (ADDED TRIPS), SATURDAY MIDDAY PEAK HOUR
ASSUMED SITE ACCESS CONFIGURATION
TUALATIN, OREGON

FIGURE
8bA

H:\proj\12116 - K-Meat Tualatin Redevelopment\figs\April2013\12116_Fig01.dwg Apr 15, 2013 4:12pm - mhughart Layout Tab: Fig08bPB

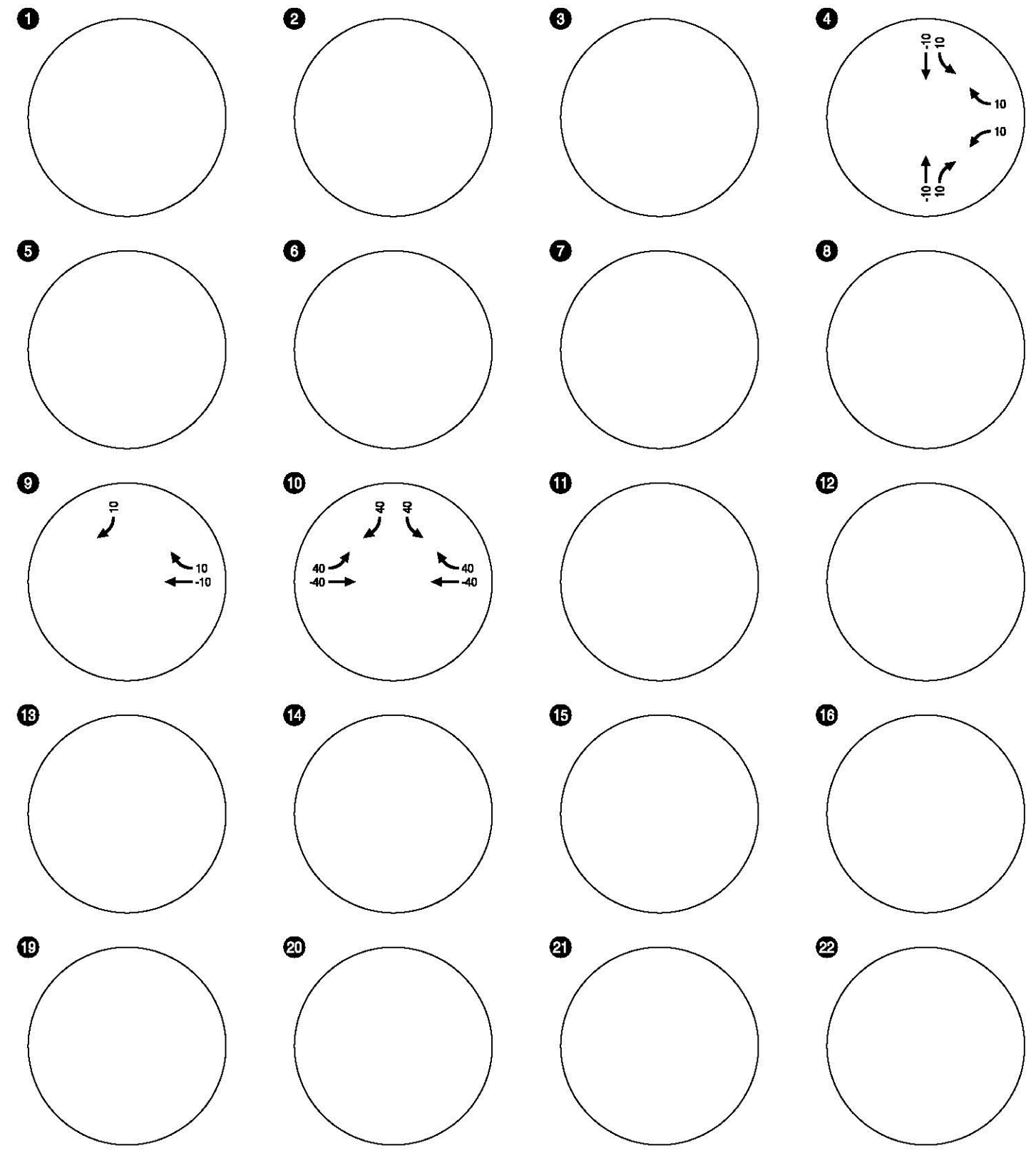
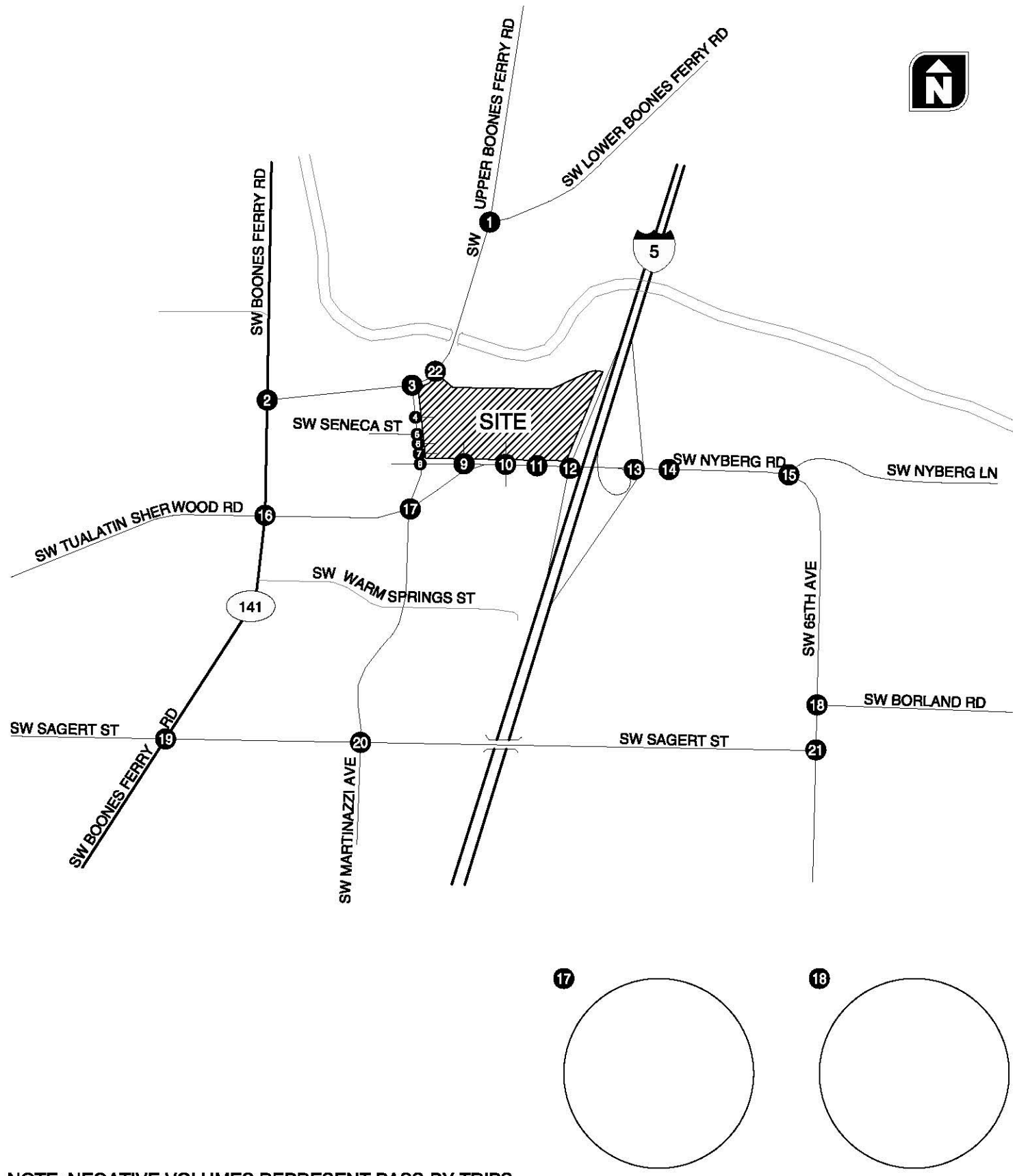

NOTE: NEGATIVE VOLUMES REPRESENT PASS-BY TRIPS

SITE-GENERATED TRIPS (PASS BY TRIPS), SATURDAY MIDDAY PEAK HOUR ASSUMED SITE ACCESS CONFIGURATION TUALATIN, OREGON **FIGURE 8bPB**

H:\projects\12116 - K-Mart Tualatin Redevelopment\dwg\figs\April2013\12116_Fig01.dwg Apr 17, 2013 - 6:32pm - cbreimer Layout Tab: Fig09A_Synchro

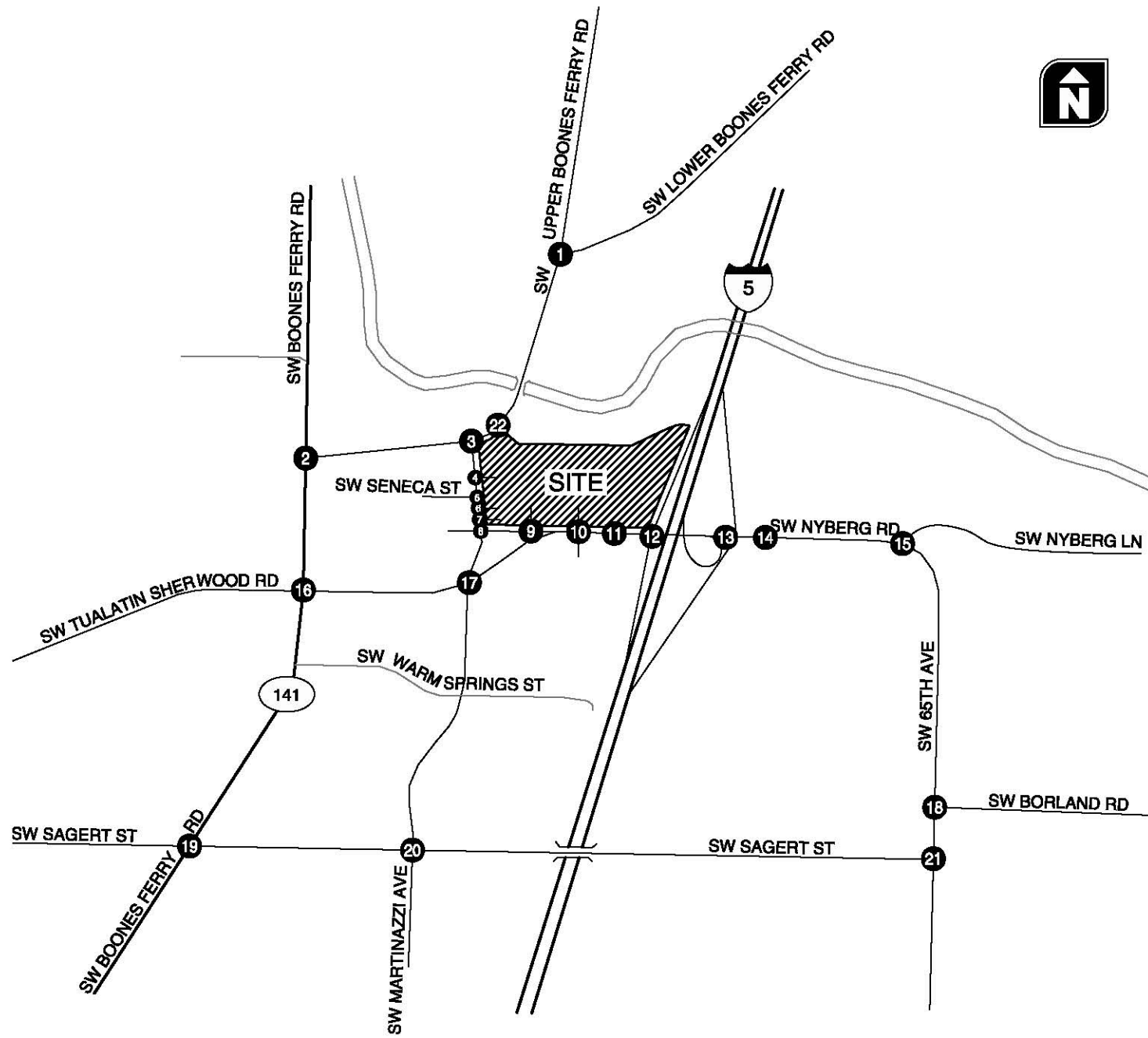

LEGEND

- CM = CRITICAL MOVEMENT (TWSC)
- LOS = INTERSECTION LEVEL OF SERVICE (SIGNALIZED/AWSC)/CRITICAL MOVEMENT LEVEL OF SERVICE (TWSC)
- Del = INTERSECTION AVERAGE CONTROL DELAY (SIGNALIZED/AWSC) / CRITICAL MOVEMENT CONTROL DELAY (TWSC)
- V/C = CRITICAL VOLUME-TO-CAPACITY RATIO
- TWSC = TWO-WAY STOP CONTROL
- AWSC = ALL-WAY STOP CONTROL

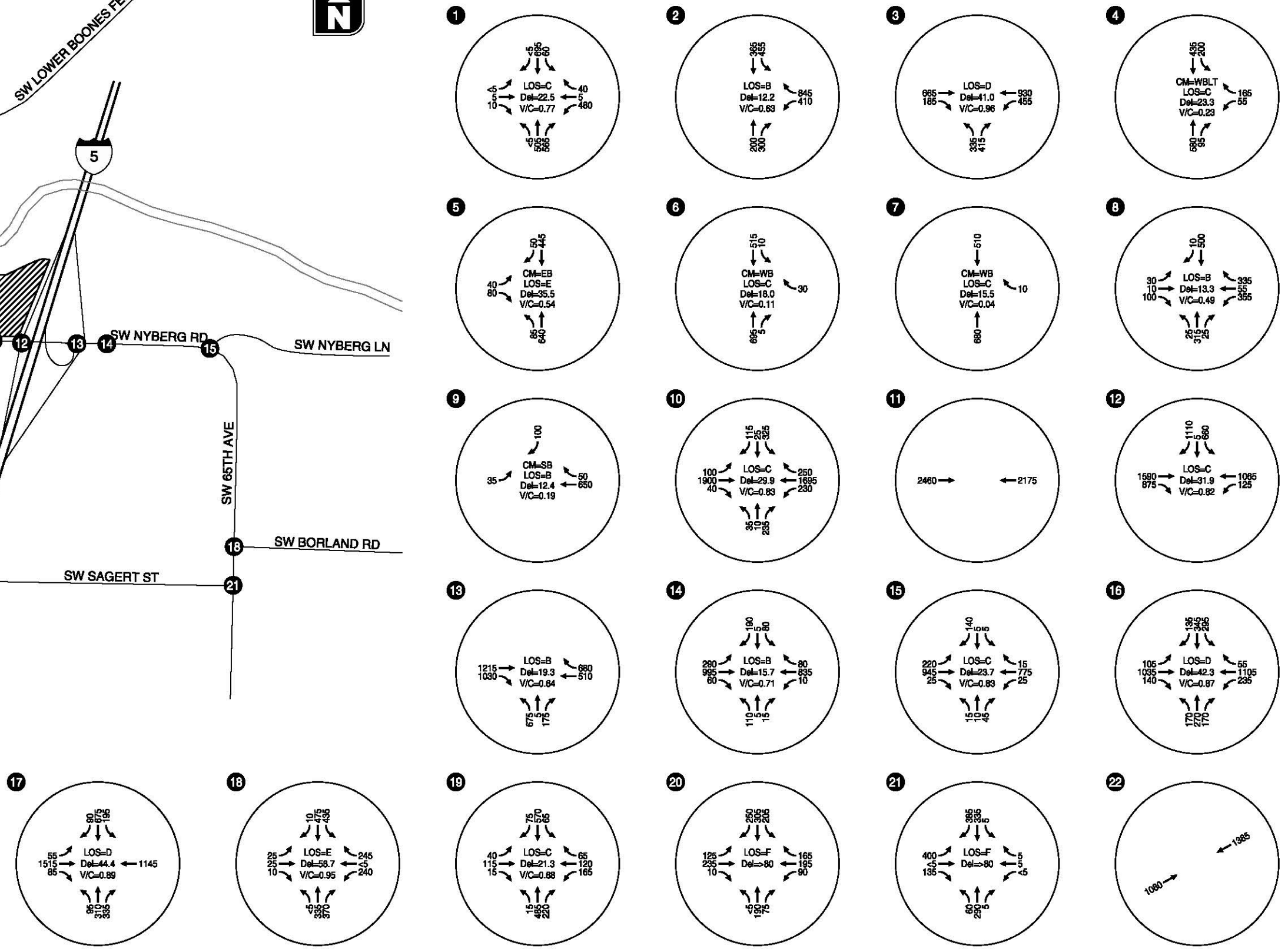

2014 TOTAL TRAFFIC CONDITIONS, WEEKDAY PM PEAK HOUR
ASSUMED SITE ACCESS CONFIGURATION
TUALATIN, OREGON

FIGURE 9A

H:\projfile\12116 - K-Meat Tualatin Redevelopment\dwg\Apr17\2013\12116_Fig01.dwg Apr 17, 2013 - 12:45pm - mhughart Layout Tab: Fig09B_Synchro

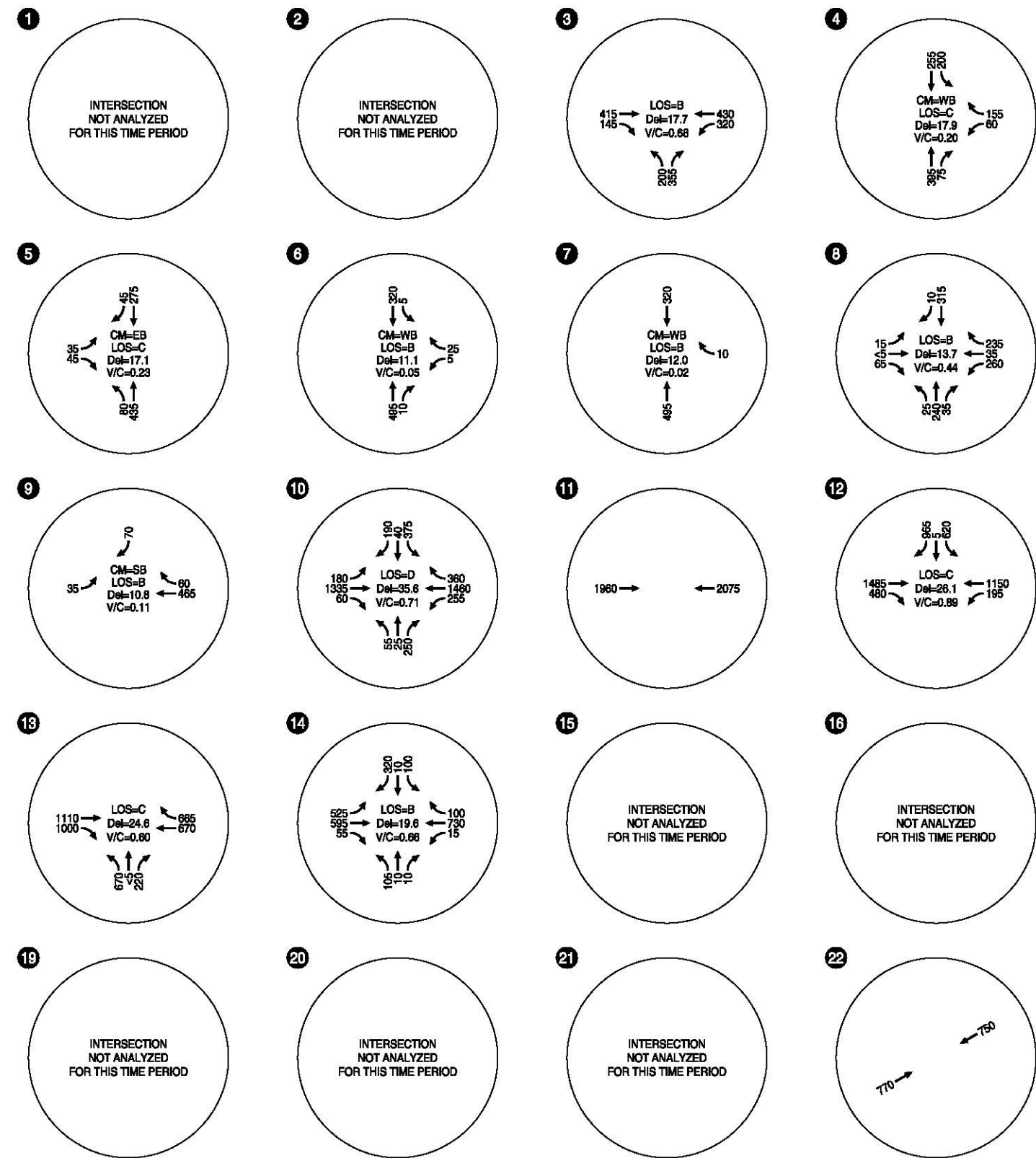
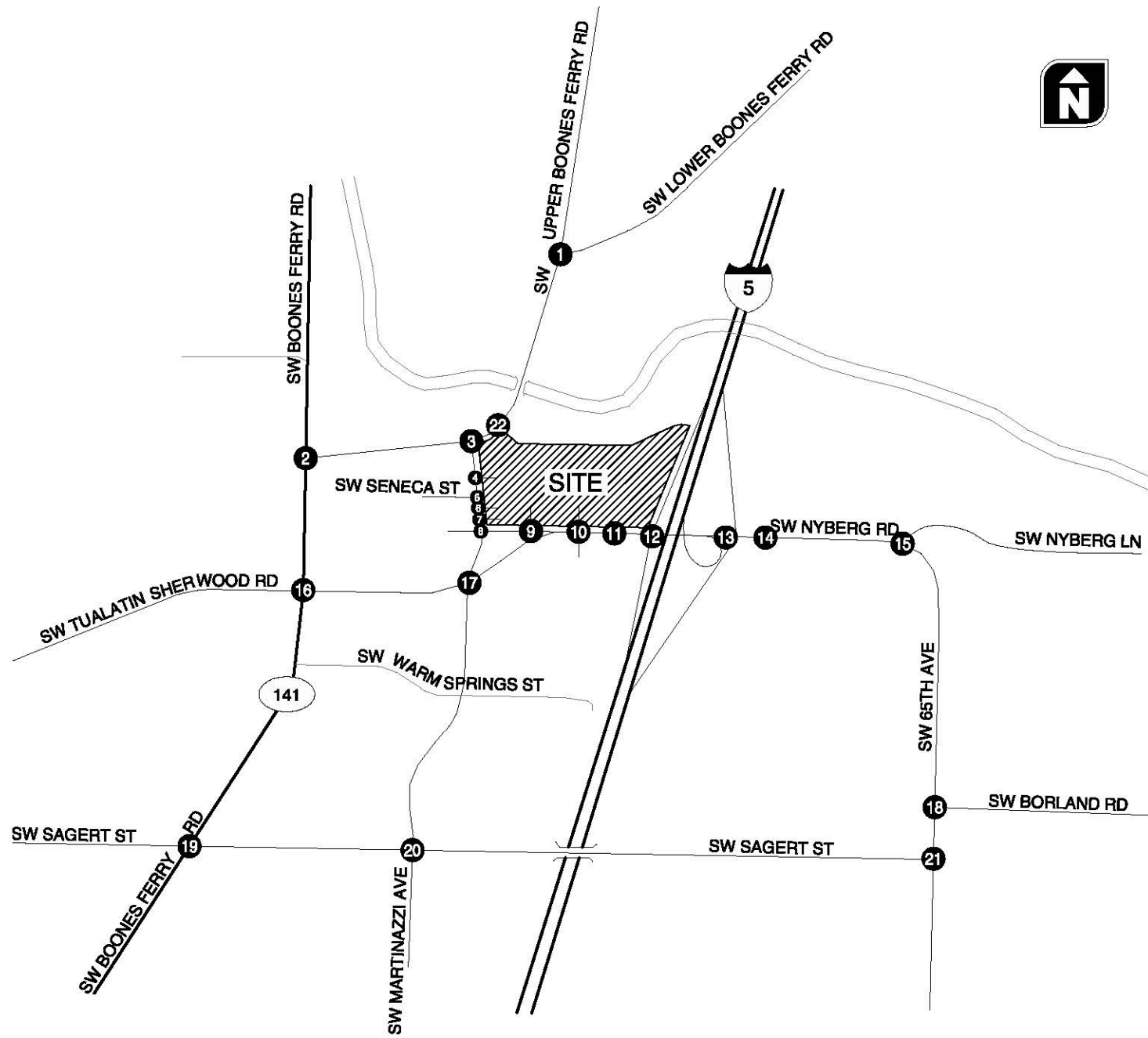

LEGEND

- CM = CRITICAL MOVEMENT (TWSC)
- LOS = INTERSECTION LEVEL OF SERVICE (SIGNALIZED/AWSC)/CRITICAL MOVEMENT LEVEL OF SERVICE (TWSC)
- Del = INTERSECTION AVERAGE CONTROL DELAY (SIGNALIZED/AWSC) / CRITICAL MOVEMENT CONTROL DELAY (TWSC)
- V/C = CRITICAL VOLUME-TO-CAPACITY RATIO
- TWSC = TWO-WAY STOP CONTROL
- AWSC = ALL-WAY STOP CONTROL

2014 TOTAL TRAFFIC CONDITIONS, SATURDAY MIDDAY PEAK HOUR
 ASSUMED SITE ACCESS CONFIGURATION
 TUALATIN, OREGON

FIGURE 9B

Table 9: 2014 Total Traffic Operations

Number	Intersection	Maximum Operating Standard	Weekday PM Peak Hour		Saturday Midday Peak Hour	
			LOS	V/C	LOS	V/C
Signalized Intersections						
1	SW Upper Boones Ferry Road/ SW Lower Boones Ferry Road/ SW Boones Ferry Road	0.99	C	0.77	Not Analyzed	Not Analyzed
2	SW Boones Ferry Road/ SW Tualatin Road	0.99	B	0.63	Not Analyzed	Not Analyzed
3	SW Boones Ferry Road/ SW Martinazzi Avenue	0.99	D	0.96	B	0.68
8	SW Nyberg Road/ SW Martinazzi Avenue	0.99	B	0.49	B	0.44
10	SW Nyberg Road/ SW Tualatin-Sherwood Road/ Fred Meyer/Site Access	0.99	C	0.83	D	0.71
12	I-5 SB Ramp Terminal/ SW Nyberg Road	0.85	C	0.82	C	0.89
13	I-5 NB Ramp Terminal/ SW Nyberg Road	0.85	B	0.64	C	0.60
14	SW Nyberg Road/ Nyberg Woods Driveway	0.99	B	0.71	B	0.66
15	SW Nyberg Road/ SW 65 th Avenue	0.99	C	0.83	Not Analyzed	Not Analyzed
16	SW Tualatin-Sherwood Road/ SW Boones Ferry Road	0.99	D	0.87	Not Analyzed	Not Analyzed
17	SW Tualatin-Sherwood Road/ SW Martinazzi Avenue	0.99	D	0.89	C	0.83
18	SW 65 th Avenue/ SW Borland Road	0.99	E	0.95	Not Analyzed	Not Analyzed
19	SW Boones Ferry Road/ SW Sagert Street	0.99	C	0.68	Not Analyzed	Not Analyzed
Unsignalized Intersections¹						
4	SW Martinazzi Avenue/ North Site Driveway	E	C	0.23	C	0.20
5	SW Martinazzi Avenue/ SW Seneca Street	E	E	0.54	C	0.23
7	SW Martinazzi Avenue/ Right-Out Only Site Driveway	E	C	0.04	B	0.02
9	SW Nyberg Road/ Site Driveway	E	B	0.19	B	0.11
22*	SW Boones Ferry Road/ Right-in/Right-Out Site Driveway	0.99	D	0.23	C	0.16
All-Way Stop-Controlled Intersections						
20	SW Sagert Street/ SW Martinazzi Avenue	D	F	N/A	Not Analyzed	Not Analyzed
21	SW Sagert Street/ SW 65 th Avenue	D	F	N/A	Not Analyzed	Not Analyzed

Notes:

¹ LOS and V/C reported for the highest delay or critical movement

* Results reported reflect SW Martinazzi Avenue and SW Boones Ferry Road Site Access Alternatives discussed beginning on page 45.

For intersections #4, #5, #6, and #7, it is recognized that the operational results shown may differ slightly due to the presence of vehicle queuing along SW Martinazzi Avenue during peak time periods.

Existing and background conditions along the Tualatin-Sherwood corridor between the I-5 ramp terminals and Boones Ferry Road reflect consistent timing parameters due to the limited change in traffic volumes. Under the total conditions, with the new site traffic, timing parameters have been optimized in a more focused effort to approximate the SCATS adaptive system’s response to the new traffic. The difference in timing optimization levels contributes to the variation in performance between background and total conditions.

Total Daily Traffic Profile

A summation of the 2014 Total Traffic daily traffic volumes is summarized in Table 10 below.

Table 10: 2014 Total Daily Traffic Profile

Roadway	Segment	Estimated Daily Volume		
		2012 Existing	2014 Background	2014 Total
SW Lower Boones Ferry Road	East of SW Upper Boones Ferry Road	13,200	13,600	13,900
SW Boones Ferry Road	East of SW Martinazzi Avenue	28,100	28,800	29,600
SW Boones Ferry Road	West of SW Martinazzi Avenue	24,400	25,100	25,400
SW Martinazzi Avenue	South of SW Boones Ferry Road and north of SW Nyberg Road	13,700	14,100	14,400
SW Martinazzi Avenue	South of SW Tualatin-Sherwood Road	17,100	17,600	18,100
SW Boones Ferry Road	North of SW Tualatin-Sherwood Road	14,000	14,500	14,500
SW Boones Ferry Road	South of SW Tualatin-Sherwood Road	15,200	15,700	16,100
SW Tualatin-Sherwood Road	West of SW Boones Ferry Road	30,800	31,800	32,300
SW Tualatin-Sherwood Road	East of SW Boones Ferry Road and west of SW Martinazzi Avenue	34,000	34,900	35,900
SW Tualatin-Sherwood Road	East of SW Martinazzi Avenue and west of SW Nyberg Road	36,400	37,400	38,300
SW Nyberg Lane	West of SW Tualatin-Sherwood Road and east of SW Martinazzi Ave	9,000	9,200	9,500
SW Nyberg Road	East of SW Tualatin-Sherwood Road and west of I-5 SB Ramp Terminal	51,900	52,900	55,900
SW Nyberg Road	West of I-5 SB Ramp Terminal and east of I-5 NB Ramp Terminal	38,600	39,600	41,300
SW Nyberg Road	East of I-5 NB Ramp Terminal and west of SW 65 th Avenue	23,100	23,800	24,300
SW 65 th Avenue	South of SW Nyberg Road	17,500	18,100	18,400
SW Borland Road	East of SW 65 th Avenue	14,900	15,400	15,700
SW 65 th Avenue	South of SW Sagert Street	9,600	9,900	10,000
SW Sagert Street	West of SW 65 th Avenue	11,500	11,900	11,900
SW Sagert Street	East of SW Martinazzi Avenue	11,200	11,600	11,700

Queuing Analysis

A 95th percentile vehicle queuing analysis was performed at the I-5 off-ramps and the SW Nyberg Road/Signalized site driveway. Per ODOT requirements, the ramp terminal queuing was assessed using SimTraffic software⁵. The queuing analysis was completed in accordance with the assumptions stipulated in the ODOT *Analysis Procedures Manual* (APM).

Each vehicle was assumed to occupy 25 feet. Table 11 summarizes the queuing analysis at the study intersections for the 2014 total traffic conditions (critical weekday p.m. peak hour). All queues reported

⁵ Tualatin-Sherwood Road between the I-5 ramp terminals and Teton Avenue currently operates with an adaptive signal system (TransCore SCATSTM), which adjusts cycle length, green splits and offsets to match capacity to traffic demands. This traffic analysis approximated the SCATS system using an upper-end cycle length based on the existing logs from the SCATS system, provided by Washington County. The Synchro/SimTraffic analysis is still a static representation of the adaptive system, thus better than reported results for delay and queue lengths are expected due to the adaptive system capabilities.

are rounded up to the nearest vehicle length. Appendix “F” contains the year 2014 total traffic queuing analysis worksheets.

Table 11: Estimated 95th Percentile Queuing Analysis

Intersection	Movement	Estimated 95 th Percentile Queue (ft)				Storage Length
		Weekday PM Peak Hour		Saturday Midday Peak Hour		
		Background Traffic	Total Traffic	Background Traffic	Total Traffic	
I-5 SB Ramp Terminal/ SW Nyberg Road	SB LT/TH	675	700	550	650	700 ¹
	SB RT	550	450	400	475	700 ¹
I-5 NB Ramp Terminal/ SW Nyberg Road	NB TH/LT	400	625	375	675	1,270
	NB RT	225	275	250	300	1,270
SW Nyberg Road/ Signalized Site Driveway	WB LT	150	150	150	150	225
	SB LT	225	200	100	200	250
	EB LT	75	150	100	225	225
	NB RT	250	275	250	250	275

NB = Northbound; SB = Southbound; EB = Eastbound; WB = Westbound

LT = Left-Turn; TH = Through; RT = Right-Turn

¹Storage length is framed by the portion of the freeway off-ramp needed to bring a vehicle to a full stop from the posted freeway speed (55 mph) at a deceleration rate of 6.5 feet/second². Ramp length is approximately 1,200 feet long with a deceleration distance of approximately 500 feet.

Table 11 shows that adequate storage exists for the forecast 95th percentile queues at the identified intersections and main sight-access driveway under total traffic conditions.

SW Martinazzi Avenue and SW Boones Ferry Road Site Access Alternatives

As part of this study, a separate site access alternative was evaluated that includes the following options:

- Adding a fourth leg (in the form of a site-access driveway) to the existing SW Martinazzi Avenue/SW Seneca Street intersection and closing the existing SW Martinazzi Avenue site driveway adjacent to the library⁶. For initial evaluation purposes, it was assumed that the modified intersection would be stop-controlled on the east-west Seneca Street approaches

⁶ It should be noted that this site-access is not required to mitigate for any impacts from the proposed development. Rather, it was evaluated in the event the City determined that it had a desire to reconfigure its property and therefore realign the access. Such realignment is not immediately required and can await the City’s preferred timeline for redevelopment of its site. For the purposes of analyzing this scenario, it was assumed that the City buildings would be relocated somewhere within the existing shopping center site to ensure that this transportation impact analysis accounted for the trips associated with those uses.

- and the new westbound approach would have a separate left- and shared through-right lane.
- Adding a new site driveway that would connect to SW Boones Ferry Road (identified as the Street “A” connection in Figure 2). Given the limited site frontage along SW Boones Ferry Road, the nearby SW Martinazzi Avenue/SW Boones Ferry Road intersection, and the nearby Tualatin River Bridge, it was assumed that this driveway connection would be limited to right-in/right-out access.

Figure 10 shows the assumed site-access configurations and traffic control devices associated with these site-access alternatives. Figures 11a and 11b summarize the resulting intersection operations for the weekday p.m. and Saturday midday peak hours.

H:\proj\12116 - K-Merit Tualatin Redevelopment\chgs\Apr12\201312116_Fig01.dwg Apr 15, 2013 - 4:13pm - mhughart Layout Tab: Fig10

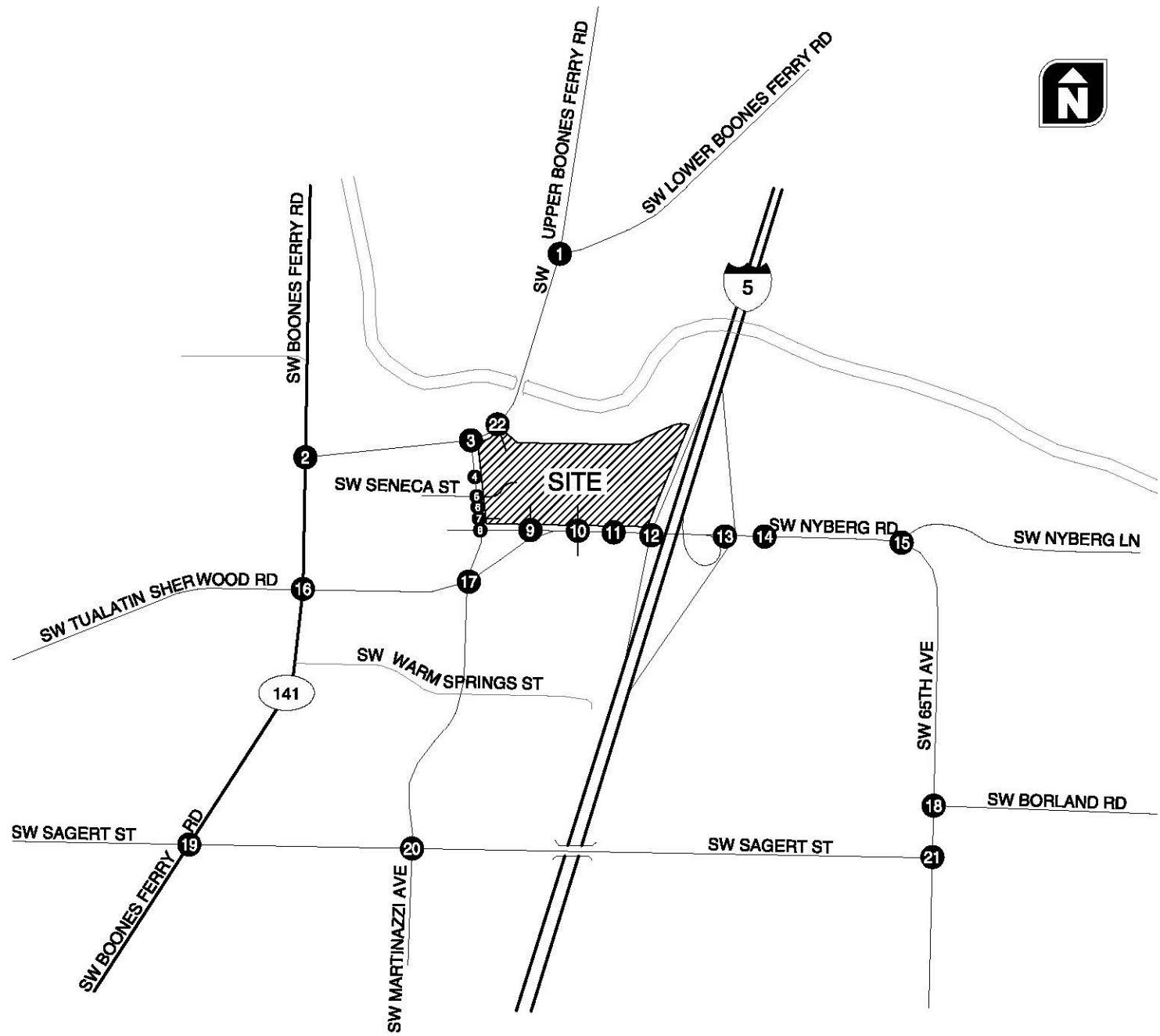

LEGEND

- NEW TRAVEL LANE
- STOP SIGN
- TRAFFIC SIGNAL

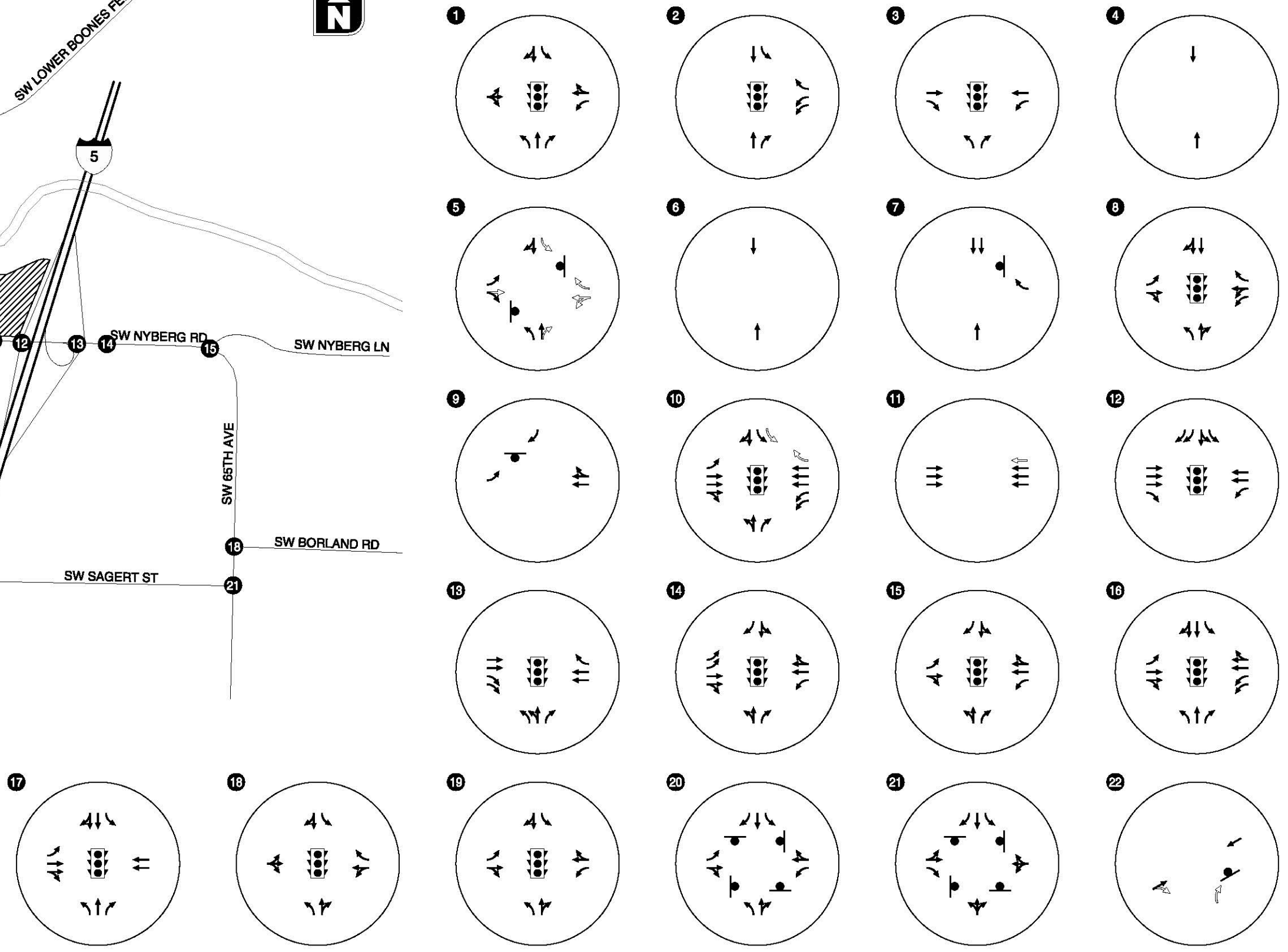

ALTERNATIVE SITE ACCESS CONFIGURATION AND TRAFFIC CONTROL DEVICES TUALATIN, OREGON

FIGURE 10

H:\projects\12116 - K-Mer Tualatin Redevelopment\chgs\Apr16, 2013 - 2:40pm - mhughart Layout Tab: Fig11A

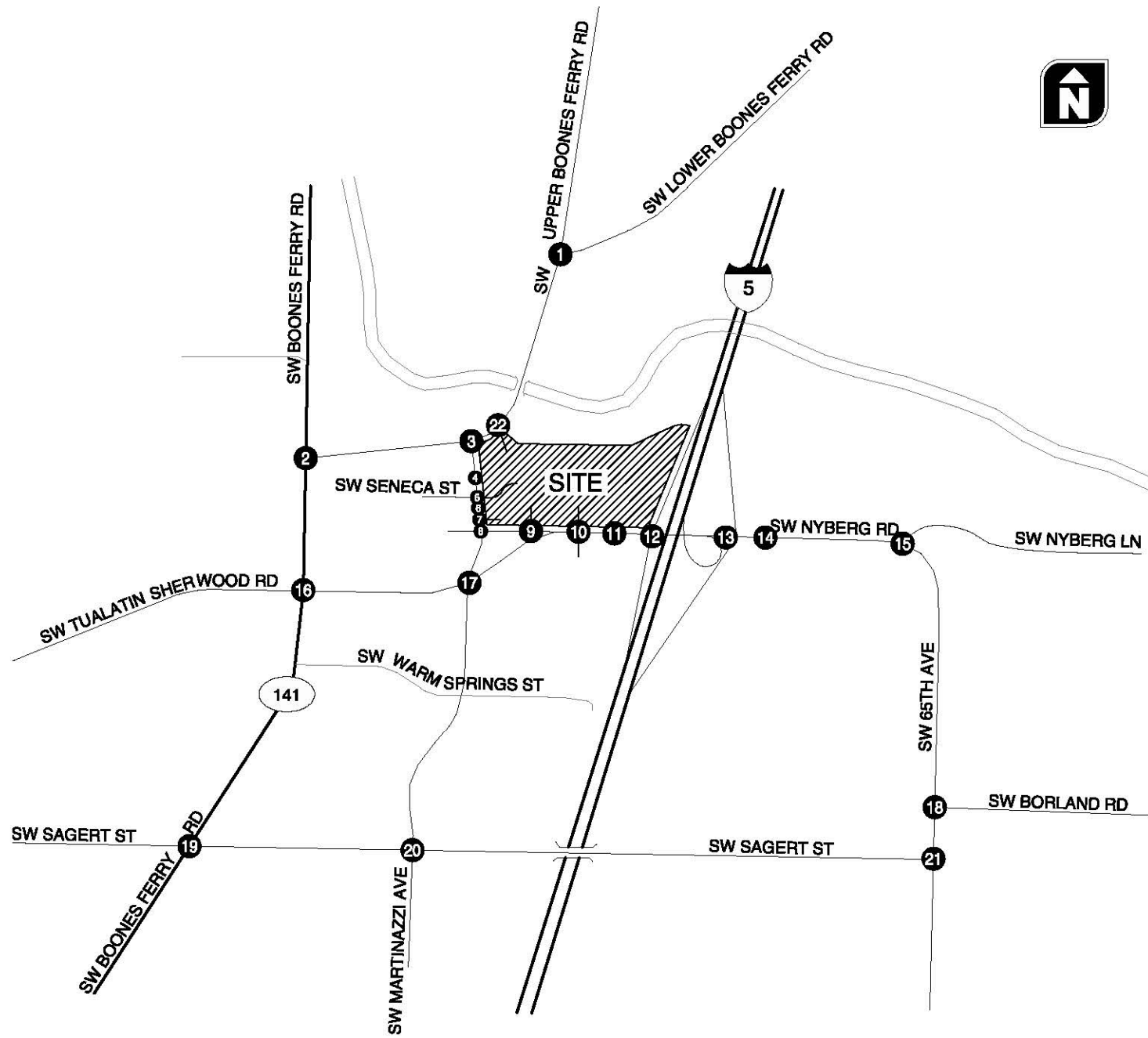

LEGEND

- CM = CRITICAL MOVEMENT (TWSC)
- LOS = INTERSECTION LEVEL OF SERVICE (SIGNALIZED/AWSC)/CRITICAL MOVEMENT LEVEL OF SERVICE (TWSC)
- Del = INTERSECTION AVERAGE CONTROL DELAY (SIGNALIZED/AWSC) / CRITICAL MOVEMENT CONTROL DELAY (TWSC)
- V/C = CRITICAL VOLUME-TO-CAPACITY RATIO
- TWSC = TWO-WAY STOP CONTROL
- AWSC = ALL-WAY STOP CONTROL

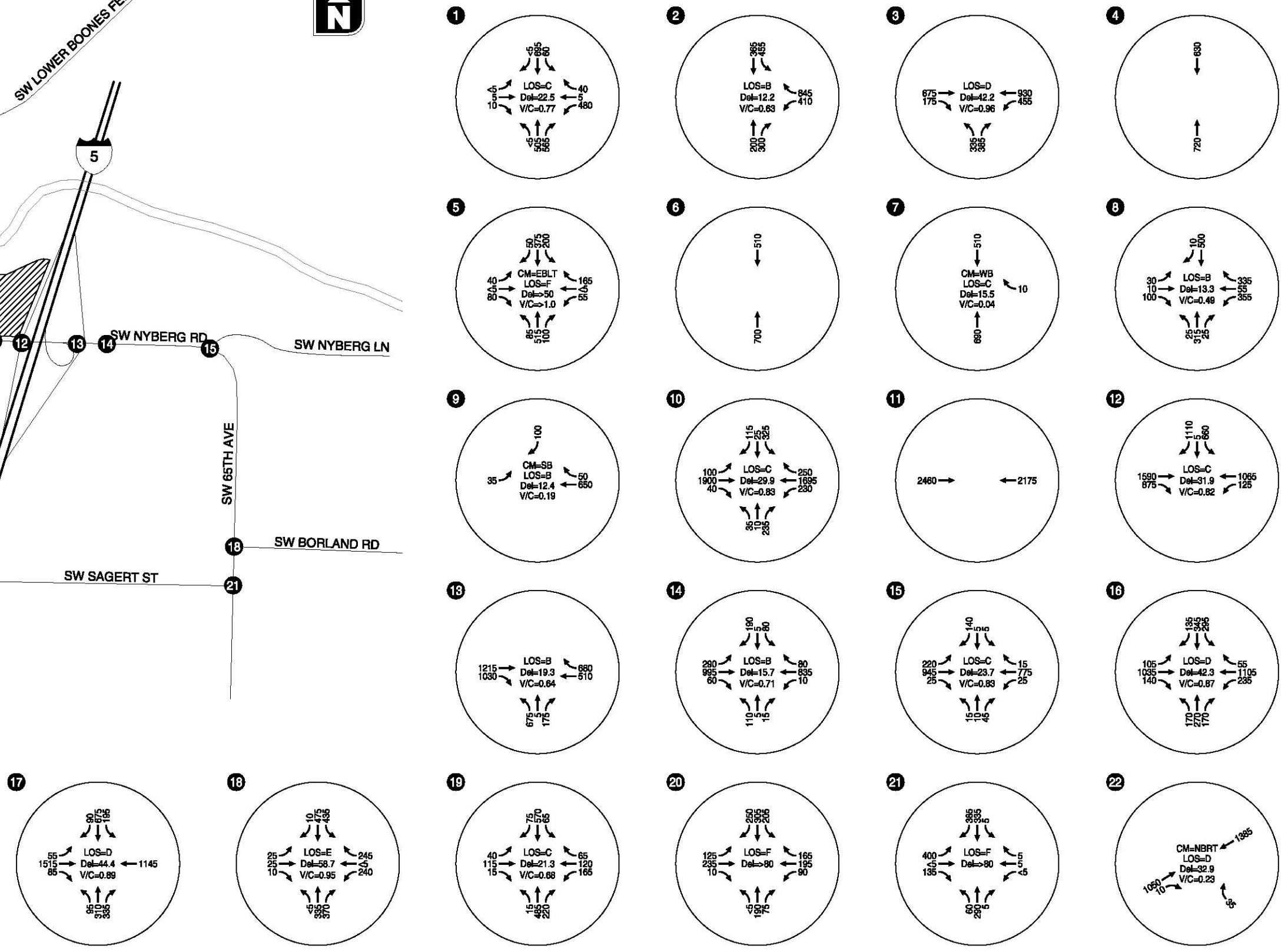

2014 TOTAL TRAFFIC CONDITIONS, WEEKDAY PM PEAK HOUR
ALTERNATIVE SITE ACCESS CONFIGURATION
TUALATIN, OREGON **FIGURE 11A**

H:\proj\12116 - K-Merit Tualatin Redevelopment\chgs\figs\Apr17, 2013 - 12:47pm - mhughart Layout Tab: Fig11B

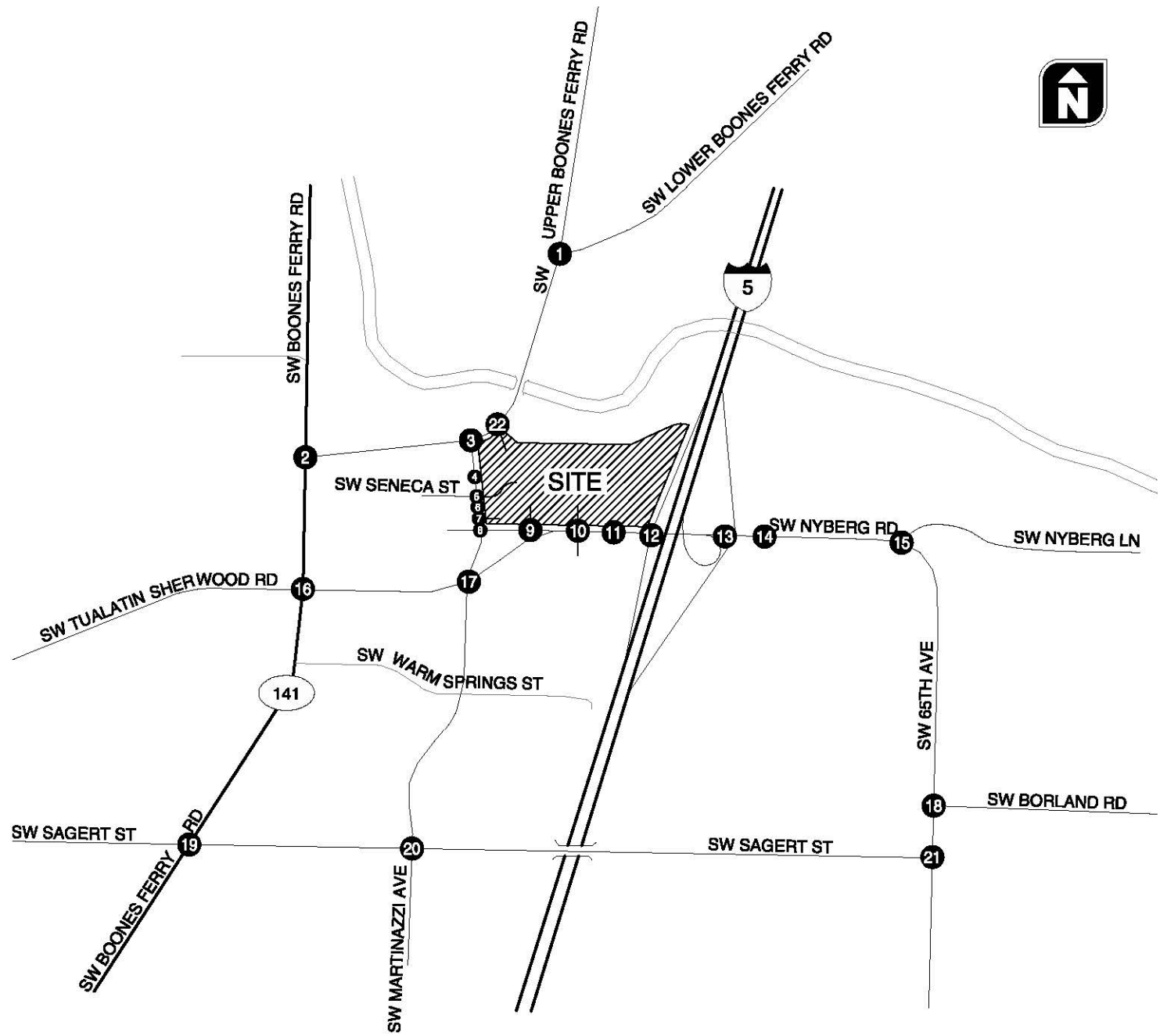

LEGEND

- CM = CRITICAL MOVEMENT (TWSC)
- LOS = INTERSECTION LEVEL OF SERVICE (SIGNALIZED/AWSC)/CRITICAL MOVEMENT LEVEL OF SERVICE (TWSC)
- Del = INTERSECTION AVERAGE CONTROL DELAY (SIGNALIZED/AWSC) / CRITICAL MOVEMENT CONTROL DELAY (TWSC)
- V/C = CRITICAL VOLUME-TO-CAPACITY RATIO
- TWSC = TWO-WAY STOP CONTROL
- AWSC = ALL-WAY STOP CONTROL

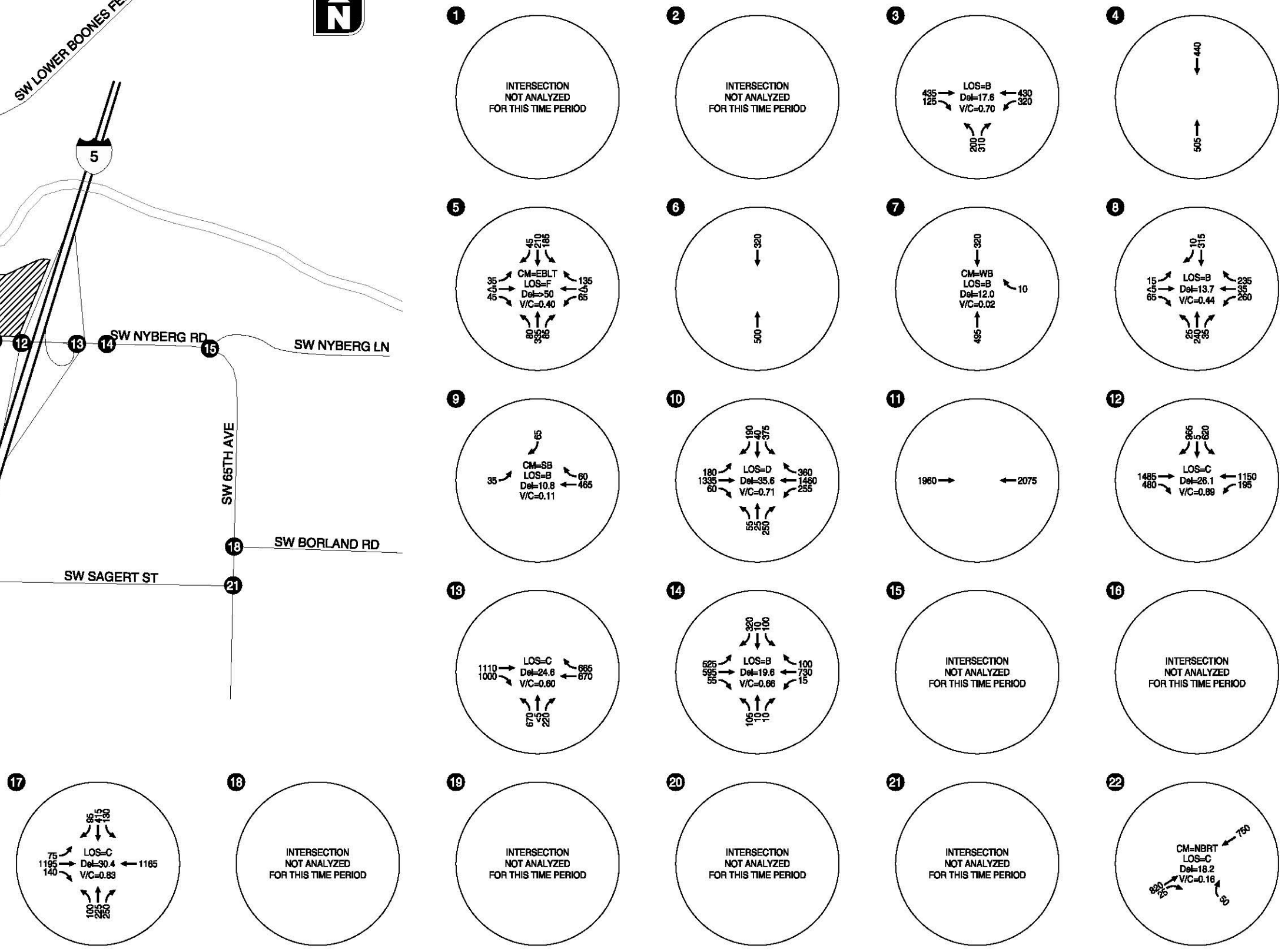

2014 TOTAL TRAFFIC CONDITIONS, SATURDAY MIDDAY PEAK HOUR ALTERNATIVE SITE ACCESS CONFIGURATION TUALATIN, OREGON

FIGURE 11B

As shown in the Figure 11a, both the eastbound and westbound left-turn volumes at the modified SW Martinazzi Avenue/SW Seneca Street intersection are forecast to operate at LOS F and over capacity during the weekday p.m. peak hour conditions under this alternative. Based on these conditions, a traffic signal with permissive left-turn phasing was evaluated as a potential mitigation measure. Table 12 summarizes the resulting operations for the weekday p.m. and Saturday midday peak hours.

Table 12: SW Martinazzi Avenue/SW Seneca Street Intersection Mitigation (2014 Total Traffic Conditions)

Mitigation	Weekday PM Peak Hour			Saturday Midday Peak Hour		
	Delay	LOS	V/C	Delay	LOS	V/C
Traffic Signal ¹	10.6	B	0.68	5.5	A	0.37
¹ Permissive left-turn phasing was assumed on all approaches.						

Table 12 indicates that signalization of the intersection will mitigate the LOS F conditions under the previously assumed two-way stop-controlled approach on SW Seneca Street. *Appendix “G” contains the year 2014 total traffic operations worksheets for the alternative access scenario at SW Martinazzi Avenue/SW Seneca Street intersection.* As indicated in Table 12, a traffic signal at the SW Martinazzi Avenue/SW Seneca Street intersection provides a significant capacity and safety benefit. In particular, signalization would:

- Provide additional excess capacity compared to an unsignalized east-west stop-controlled intersection.
- Enhance east-west pedestrian movements by providing a signalized crossing where one does not exist today.

From a signal operations standpoint, progression along SW Martinazzi Avenue is constrained by the endpoints of SW Tualatin-Sherwood Road and SW Boones Ferry. Operational analysis indicates a new signal at Seneca and the existing signal at SW Martinazzi Avenue/SW Boones Ferry Road could operate well during the peak period as a fully actuated, uncoordinated signal. Queuing should be monitored, particularly for other time periods to determine if including one or both of these signals into the adaptive signal system would be advantageous. Note, the new signal at Seneca provides much needed queue management on SW Martinazzi (as seen in SimTraffic modeling) to facilitate traffic flows and represents a large improvement over the no-build conditions for the assumed 2014 traffic demand.

In addition to the modified SW Martinazzi Avenue/SW Seneca Street intersection, Figures 11a and 11b demonstrate the impacts of adding a limited access site-driveway to SW Boones Ferry Road (Street “A” connection). The analysis shows that the driveway would provide a direct connection to SW Boones Ferry Road, but that it would not provide an operational benefit to any other study intersection of site driveway beyond the base site layout analysis.

IMPACTS OF THE NYBERG RIVERS DEVELOPMENT ON IDENTIFIED TRANSPORTATION PLANNING PROJECTS

Figure 1 of the current Tualatin Transportation System Plan (TSP) has identified a future minor collector (Cb) roadway through the proposed Nyberg Rivers development area that would connect SW Nyberg Road to SW Boones Ferry Road. The TSP does not identify a specific alignment for this roadway. The *Tualatin Town Center Plan* subsequently identifies this connection as a “loop road” that would conceptually extend from SW Boones Ferry Road around the Kmart building and internally connect with a future Seneca Street extension from the west. The TSP and Town Center Plan do not specifically address how or where the loop road would make the final connection to SW Nyberg Road.

The Nyberg Rivers redevelopment project has proposed an on-site roadway network that will meet the intent of the loop road connection and completes the connection to SW Nyberg Road. While not meeting all the specific design requirements called for in the City’s proposed collector roadway designation, offers the functionality and connectivity that would be provided by a fully developed collector street system. The proposal includes the following:

- A new roadway connection to SW Boones Ferry Road (shown as "Street A" in Figure 2) that includes sidewalks.
- An enhanced site-access driveway to SW Nyberg Road that will better accommodate vehicular queuing and demand.
- A potential future (assuming the City desires to move forward) new site-access connection to SW Martinazzi Avenue that aligns across from SW Seneca Street. This connection would be the Seneca Street extension envisioned in the Town Center Plan. Prior to the City making a decision on any new SW Street Seneca alignment, the redevelopment site plan preserves this connection opportunity in the present or future.
- The preservation of east-west and north-south travel ways that will provide vehicular and pedestrian access between Street A, the Seneca Street alignment/extension, and enhanced access to SW Nyberg Road.
- New sidewalks along the enhanced site-access driveway to SW Nyberg Road that provide pedestrian connections to the integrated site circulation network.
- New bikeway connections along the perimeter of the site.

While all of these elements contribute towards the desired connectivity identified in the Tualatin TSP, development to full city standards is difficult for the following reasons:

- The TSP and Town Center Plan do not specifically address how or where the loop road would connect to SW Nyberg Road, however the graphics suggest the connection would occur somewhere within the vicinity of the existing SW 75th Avenue connection to SW Nyberg Road. Based on current ODOT access management policies, it is recognized that ODOT would not allow such a connection to be made given that it would be within 200-300 feet of the I-5 Southbound ramp terminal. Instead, it has been assumed that the existing SW

Nyberg Road/signalized site driveway would represent the only access connection that ODOT would continue to support within the influence area of the interchange.

- The proposed Nyberg Rivers project is not a complete redevelopment of the existing shopping center site. A large number of existing uses (Michaels, US Bank, Banner Bank, Tualatin City Library and administrative offices, and other retail space) will remain on the site. As a result, much of the site layout (including buildings and parking areas) will remain substantially unchanged.
 - For example, the "loop road" concept in the Tualatin Town Center Plan suggested that the conceptual connection occur around and behind the existing Kmart building. As noted in the proposed development plan, this area of the site will be redeveloped with retail pads. A limited site configuration for the placement of new buildings and a need to maintain a sizable number of existing buildings/parking areas does not accommodate a "loop road" alignment.

Section 5
Conclusions and Recommendations

CONCLUSIONS AND RECOMMENDATIONS

The results of this study indicate that the proposed Nyberg Rivers redevelopment project can be constructed while maintaining acceptable traffic operations and safety at the study intersections, assuming provision of the recommended mitigation measures.

FINDINGS

Year 2012 Existing Conditions

- All of the study intersections currently operate acceptably during the weekday p.m. and Saturday midday peak hours with the exception of the SW Martinazzi Avenue/SW Sagert Street and SW 65th Avenue/SW Sagert Road intersections.
 - At both the SW Martinazzi Avenue/SW Sagert Street and SW 65th Avenue/SW Sagert Street intersections, the southbound approach during the weekday p.m. peak hour operates at LOS F.

Year 2014 Background Traffic Conditions

- All of the study intersections are forecast to operate acceptably during the weekday p.m. and Saturday midday peak hours with the exception of SW Martinazzi Avenue/SW Sagert Road and SW 65th Avenue/SW Sagert Road intersections.
 - At both the SW Martinazzi Avenue/SW Sagert Street and SW 65th Avenue/SW Sagert Street intersections, the southbound approach during the weekday p.m. peak hour is forecast to continue to operate at LOS F. These findings are consistent with analysis conducted as part of the recent Tualatin Transportation System Plan (TSP) Update and future improvements are identified within the TSP for both of these intersections.

Proposed Redevelopment Plan

- Under the redevelopment plan, the existing SW 75th Avenue connection to SW Nyberg Road will be closed to improve access management along SW Nyberg Road and to better accommodate the redevelopment proposal.
- The existing signalized access on SW Nyberg Road that currently serves the shopping center and the adjacent Fred Meyer site will remain. However, the following changes are proposed in order to better accommodate the proposed redevelopment, provide additional capacity for future growth in traffic, and improve safety relative to the existing condition:
 - A westbound right-turn lane will be developed on SW Nyberg Road to enhance access to the site and minimize vehicle queuing on SW Nyberg Road.

- The existing site driveway is proposed to be widened as shown in the proposed site plan. This widening will include dual southbound left-turn lanes, a shared through/right-turn lane, and dual in-bound receiving lanes. A raised median will be constructed in the driveway throat to reduce turning conflicts on-site turning maneuvers and manage vehicle queues on the approach to the signal.
- The north and south approach signal phasing is proposed to be modified from permissive left-turn phasing to split phasing.
- With the anticipated mix of new retail uses, the proposed redevelopment is estimated to generate 405 net new trips during the weekday p.m. peak hour and 725 net new trips during the Saturday midday peak hour.

Year 2014 Total Traffic Conditions

- All of the study intersections within the immediate site vicinity, including the site access points and internal site intersections, are forecast to operate acceptably during the weekday p.m. and Saturday midday peak hours.
- The SW Martinazzi Avenue/SW Sagert Road and SW 65th Avenue/SW Sagert Road intersections are forecast to continue to operate at LOS F.
 - The proposed development will have an insignificant impact at either intersection, resulting in an estimated 1.6% and 0.6% increase, respectively, during the weekday p.m. peak hour.
 - The Tualatin TSP has identified mitigations for these two intersections that, when implemented, will address the long-term operations.
 - The Washington County Transportation Development Tax (TDT) in part funds an improvement project on SW Sagert Street that will add capacity and reduce delay to both intersections.
- Beyond the site's frontage along SW Tualatin Sherwood Road and SW Martinazzi Avenue, where significant transportation improvements are proposed (including implementing the intent of the City's Loop Road), the project will have an insignificant impact on the other study intersections (generally resulting in less than a two percent increase in traffic relative to 2014 background conditions).
- At all signalized intersections beyond the site frontage (with the exception of the I-5 interchange), the project will add on average one vehicle or less per signal cycle to any movement. This level of impact is less than significant by any traffic engineering standard and well below the level that would be perceived by motorists.
- Anticipated vehicle queues can be accommodated at the I-5 ramp terminals and the SW Nyberg Road/Signalized site driveway.

- The proposed Nyberg Rivers redevelopment project has proposed an on-site roadway network that will meet the intent of the loop road connection. The proposal includes the following:
 - A new roadway connection to SW Boones Ferry Road (shown as "Street A" in Figure 2) that includes sidewalks.
 - An enhanced site-access driveway to SW Nyberg Road that will better accommodate vehicular queuing and demand.
 - A potential future (assuming the City desires to move forward) new site-access connection to SW Martinazzi Avenue that aligns across from SW Seneca Street. This connection would be the Seneca Street extension envisioned in the Town Center Plan. Prior to the City making a decision on any new SW Street Seneca alignment, the redevelopment site plan preserves this connection opportunity in the present or future.
 - The preservation of east-west and north-south travel ways that will provide vehicular and pedestrian access between Street A, the Seneca Street alignment/extension, and enhanced access to SW Nyberg Road.
 - New sidewalks along the enhanced site-access driveway to SW Nyberg Road that provide pedestrian connections to the integrated site circulation network.
 - New bikeway connections along the perimeter of the site.

SW Martinazzi Avenue and SW Boones Ferry Road Site Access Alternatives

- An alternative site access scenario was evaluated that demonstrates the impact of potentially adding a fourth leg (in the form of a site-access driveway) to the existing SW Martinazzi Avenue/SW Seneca Street intersection and closing the existing SW Martinazzi Avenue site driveway adjacent to the library. This analysis produced the following results:
 - The east and west approaches to a modified SW Martinazzi Avenue/SW Seneca Street intersection would operate at Level of Service (LOS) F and over capacity during the weekday p.m. peak hour with the addition of a fourth site-access leg. Signaling the intersection would provide the following:
 - Mitigation that results in LOS A or better (a significant improvement over existing conditions).
 - Additional excess intersection capacity beyond what is needed to serve the Nyberg Rivers project traffic.
 - Enhanced east-west pedestrian connectivity across SW Martinazzi Avenue.
 - A safety improvement relative to stop sign control.

- In addition to the modified SW Martinazzi Avenue/SW Seneca Street intersection, another site-access alternative was evaluated that demonstrates the impacts of adding a limited access site-driveway to SW Boones Ferry Road. The analysis shows that with a direct connection to SW Boones Ferry Road, there would be some shifting of site-generated traffic off of SW Martinazzi Avenue. This additional access would further improve connectivity, help implement the City's loop road concept, and provide additional capacity beyond what is needed to serve the Nyberg Rivers project.

RECOMMENDATIONS

- With the proposed Nyberg Rivers redevelopment:
 - The existing SW 75th Avenue site-access driveway to SW Nyberg Road should be closed in order to minimize turning movement conflicts, allow for the construction of a westbound right-turn lane at the SW Nyberg Road/signalized site driveway, and improve the interchange access spacing conditions along SW Nyberg Road.
 - To better accommodate the anticipated site-generated traffic at the SW Nyberg Road/Signalized site driveway:
 - A new westbound right-turn lane should be constructed on SW Nyberg Road.
 - The site driveway should be modified to include dual southbound left-turn lanes, a shared through/right-turn lane, and two inbound receiving lanes.
 - The existing north/south traffic signal phasing should be modified from permissive phasing to split phasing. Right-turn overlap phasing should be provided for the westbound right-turn movement into the Nyberg Rivers site.
- If site access to SW Martinazzi Avenue is provided via a new fourth leg to the SW Martinazzi Avenue/SW Seneca Street intersection, the intersection should be signalized.
- If a new site access driveway is provided to SW Boones Ferry Road, the driveway should be limited to right-in/right-out only access.

Appendix A
Scoping Memorandum



DRAFT SCOPING MEMORANDUM #1

Date: August 22, 2012 **Project #:** 12116

To: Kaaren Hofmann, P.E., Tony Doran, City of Tualatin
Jinde Zhu, P.E., Washington County
Avi Tayar, P.E., Doug Baumgartner, Marah Danielson, ODOT

From: Matt Hughart, AICP; Chris Brehmer, P.E.; Mark Vandehey, P.E.

Project: Nyberg Woods II – Tualatin, OR

Subject: Proposed Traffic Study Scope of Work

The purpose of this memorandum is to provide an opportunity for the City of Tualatin, Washington County, and ODOT staff to review and provide guidance on project assumptions associated with conducting a traffic study for a proposed partial redevelopment of the existing K-Mart shopping center in Tualatin, Oregon. Details of the proposed project assumptions are documented below.

Proposed Development Plan

The project entails a partial redevelopment of the existing shopping center currently anchored by a K-Mart and supported by a number of other retail uses. While a specific site plan and tenant mix is still being developed, the redevelopment will likely entail the following components:

- K-Mart will close and its existing 96,799 square foot building will be removed.
- The existing adult cabaret will close and its 4,800 square foot building will be removed.
- Approximately 208,180 square feet of new shopping center uses and 30,000 square feet of office space will be constructed on the site.
- The existing 3,500 square foot building currently occupied by a Wendy's will be relocated to a new pad within the shopping center site.
- All other existing buildings will remain and their uses will continue to operate as is.
- The existing 75th Avenue access to SW Nyberg Road is proposed to be closed.

- The existing signalized access on SW Nyberg Road that currently serves the site and the Fred Meyer site will remain. The traffic study will look at potential enhancements to this intersection to better accommodate site traffic and vehicle queuing.
- The traffic study will look at different access scenarios to SW Martinazzi Avenue and SW Boones Ferry Road. Specifically, the impacts/improvements necessary to realign the existing SW Martinazzi Avenue driveway (adjacent to the library/city hall) to access SW Martinazzi Avenue across from Seneca Street and a new site access driveway to SW Boones Ferry Road.

Proposed Study Intersections

A preliminary list of study intersections was identified based on the size of the anticipated development and its location. This list of intersections is identified below. Figures 1 and 2 illustrate their location and associated lane configurations/traffic control devices.

- SW Martinazzi Avenue/SW Boones Ferry Road (#3)
- SW Martinazzi Avenue/Existing Site Driveway (near City Hall) (#4)
- SW Martinazzi Avenue/SW Seneca Street (#5)
- SW Martinazzi Avenue/Existing Site Driveway (#6)
- SW Martinazzi Avenue/Existing Right-Out Only Driveway (#7)
- SW Tualatin-Sherwood Road/SW Martinazzi Avenue (#17)
- SW Nyberg Street/SW Martinazzi Avenue (#8)
- SW Nyberg Street/Unsignalized Site Driveway (#9)
- SW Nyberg Street/SW Tualatin-Sherwood Road/Fred Meyer/Site Driveway (#10)
- SW Nyberg Street/SW 75th Avenue (#11)
- SW Nyberg Street/I-5 SB Ramp Terminal (#12)
- SW Nyberg Street/I-5 NB Ramp Terminal (#13)
- SW Nyberg Street/Signalized entrance to Nyberg Woods (#14)

In anticipation of the need to study these intersections at a minimum, traffic counts were obtained in May 2012 (before the end of the spring school semester) during the analysis periods discussed in the following section.

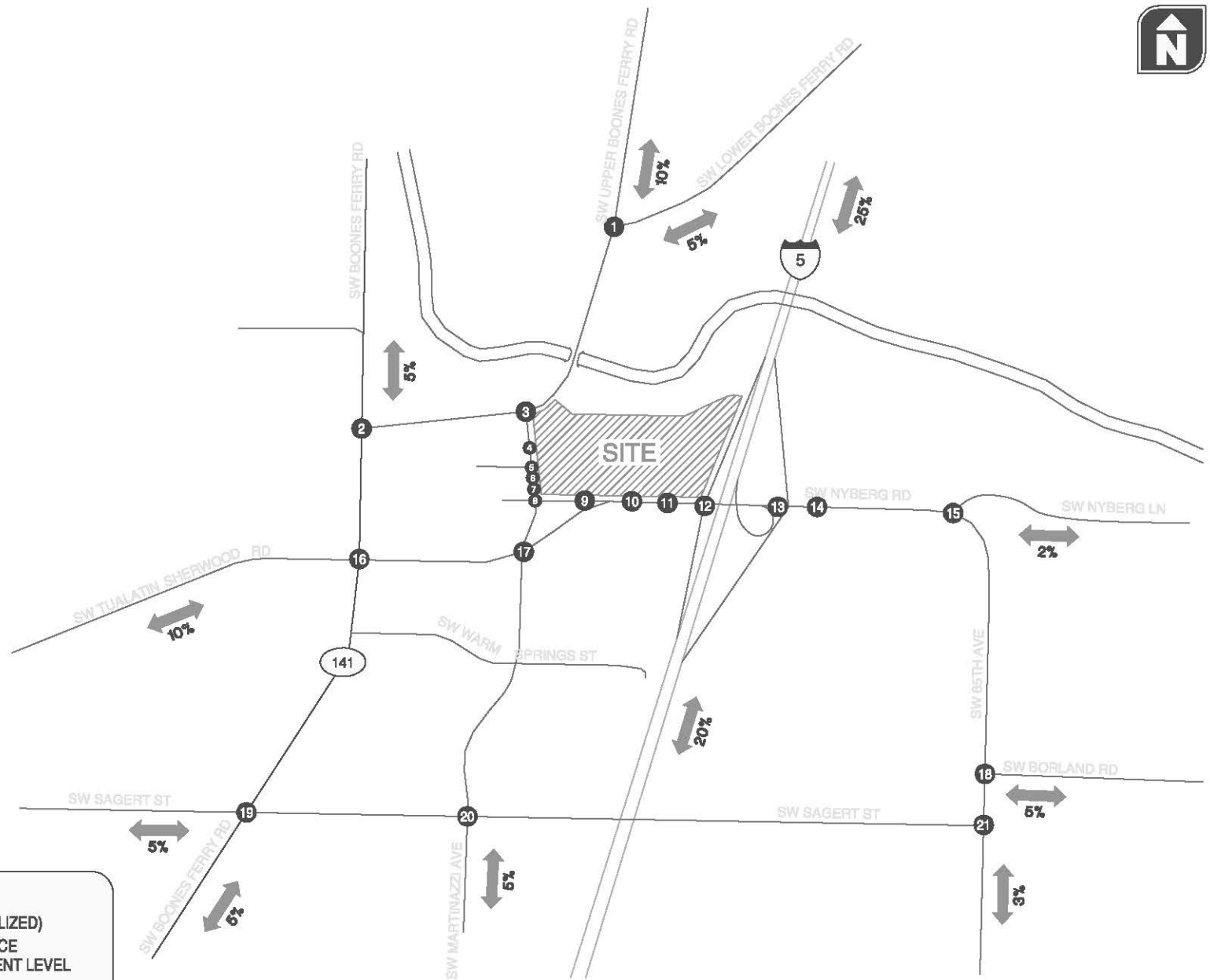

LEGEND

- CM = CRITICAL MOVEMENT (UN SIGNALIZED)
- LOS = INTERSECTION LEVEL OF SERVICE (SIGNALIZED)/CRITICAL MOVEMENT LEVEL OF SERVICE (UN SIGNALIZED)
- Del = INTERSECTION AVERAGE CONTROL DELAY (SIGNALIZED)/CRITICAL MOVEMENT CONTROL DELAY (UN SIGNALIZED)
- V/C = CRITICAL VOLUME-TO-CAPACITY RATIO

STUDY INTERSECTIONS AND TRIP DISTRIBUTION PATTERN TUALATIN, OREGON

FIGURE 1

H:\projects\12116 - Nyberg Woods\chgs\figs\Fig01.dwg Aug 16, 2012 - 6:55pm - zclark Layout Tab: Fig01

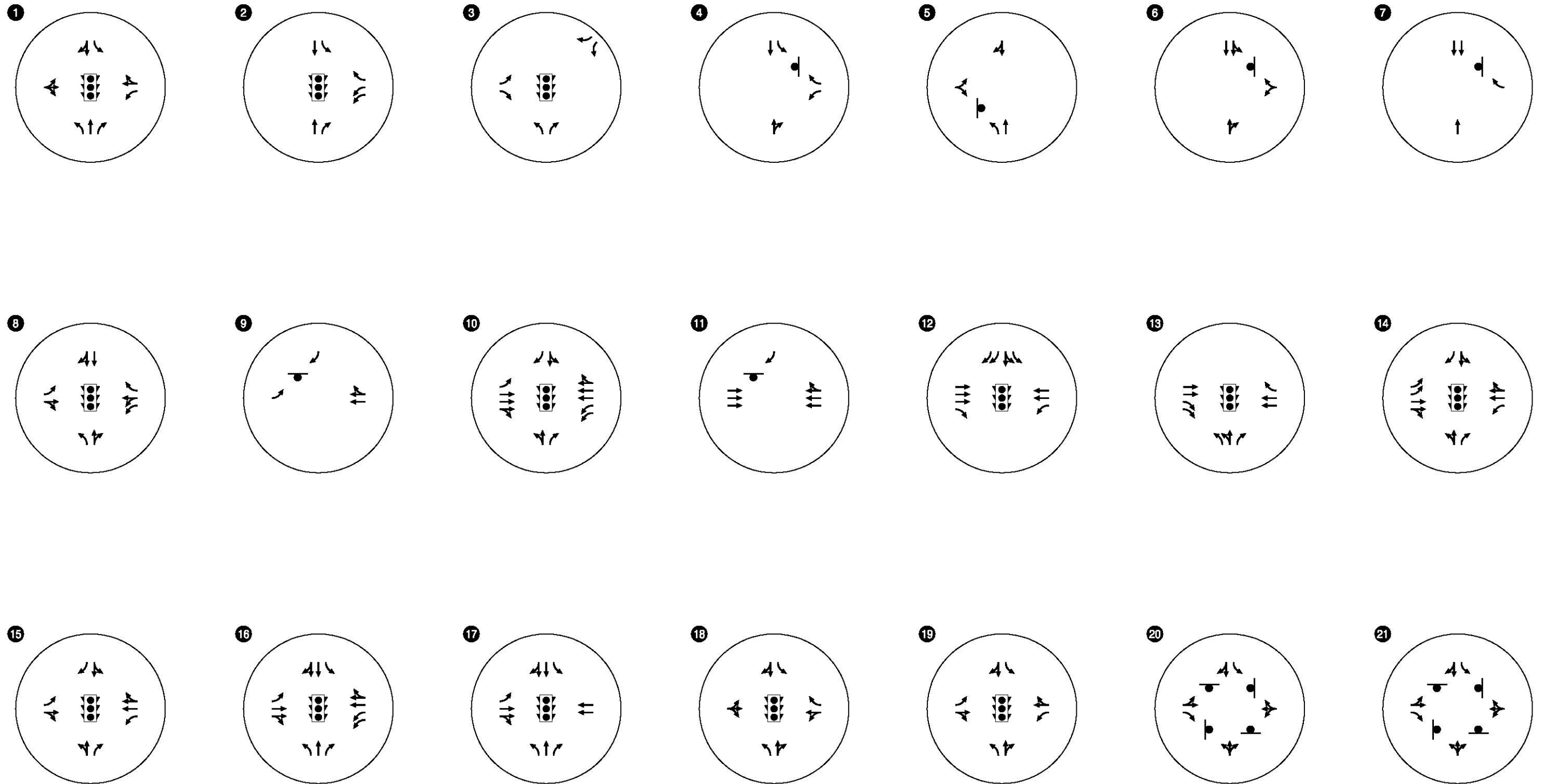

LEGEND

-  - STOP SIGN
-  - TRAFFIC SIGNAL

LANE CONFIGURATION AND TRAFFIC CONTROL DEVICES TUALATIN, OREGON

FIGURE 2

H:\projfile\12116 - Nyberg Woods\dwg\figs\fig01.dwg Aug 16, 2012 - 4:18pm - zclark Layout Tab: Fig02

Traffic Analysis Periods and Scenarios

In order to assess the impact of the proposed development, traffic conditions are proposed to be analyzed during the peak hour of the following time periods:

- Weekday evening roadway peak hour (3:00-6:00 p.m.)
- Saturday midday peak hour (11:00 a.m. - 2:00 p.m.)

The proposed redevelopment is anticipated to be completed by 2014. Intersections are proposed to be analyzed for the following three time periods:

- Existing (2012)
- Background (without shopping center redevelopment) (2014)
- Total Traffic (with shopping center redevelopment) (2014)

EXISTING CONDITIONS ANALYSIS

The existing operations will be assessed at the identified study intersections during the weekday evening and Saturday midday peak periods using the traffic data collected. Synchro 8 analysis software will be used in accordance with the methodology in the *2010 Highway Capacity Manual* and the *ODOT Analysis Procedures Manual* (where applicable). The most recent 5-year crash data at each study intersection will be obtained and reviewed.

BACKGROUND ANALYSIS

This analysis will assess traffic operations at the study intersections during the two study periods in the year 2014 without any improvements or changes to the roadway network. Traffic volumes for the year 2014 will be based on an assumed growth rate of 1.0% per year. This near-term growth rate was derived from a review of Washington County traffic counts on Tualatin-Sherwood Road and Nyberg Street. In-process development data will be obtained from the City of Tualatin and Washington County and included as part of year 2014 forecast traffic volumes.

TRIP GENERATION

Given that the proposed project is only a partial redevelopment of the larger shopping center, a trip generation methodology was developed that would more accurately reflect the characteristics of a unified and vibrant shopping center. This methodology is outlined in greater detail in Appendix A. The resulting trip estimate is summarized in Table 1 below.

Table 1 Trip Generation

	ITE Code	Size (sq. ft.)	Weekday PM Peak Hour			Saturday Midday Peak Hour		
			Total	In	Out	Total	In	Out
Existing Site								
Existing Site Driveways ¹	-	-	945	435	510	970	490	480
Less Existing Library ²	590	22,123	(160)	(75)	(85)	(150)	(80)	(70)
Less Existing Civic Uses ³	715	~10,000	(50)	(10)	(40)	-	-	-
Total Existing Retail			735	350	385	820	410	410
Future Site								
Shopping Center	820	264,924 ⁴	1,225	600	625	1,615	840	775
Less Existing Retail Driveway Counts	-	-	(735)	(350)	(385)	(820)	(410)	(410)
Sub Total	-	-	490	250	240	795	430	365
Pass-by Trips (Weekday 34%, Sat. 26%)	-	-	(160)	(80)	(80)	(190)	(95)	(95)
Office	710	30,000	45	10	35	10	5	5
Net New Trips			375	180	195	615	340	275

¹Represents the total site driveway counts during the weekday p.m. peak hour of 4:35-5:35 p.m. and Saturday midday peak hour of 12:10-1:10 p.m. This is the traffic volume being generated by the existing 158,343 square feet of shopping center currently residing on the site.

²The library traffic counts were estimated using the *Library* land use in ITE Trip Generation.

³The City Hall traffic counts were estimated using the *Single Tenant Office Building* land use in ITE Trip Generation. The existing City Hall square footage was estimated to be approximately 10,000 square feet in size.

⁴Includes the 158,343 square feet of existing shopping center (minus the 96,799 square foot K-Mart and 4,800 square foot adult cabaret) plus the 208,180 square feet of proposed shopping center uses.

TRIP ASSIGNMENT

The trip distribution pattern for the proposed project was estimated based on a select zone assignment obtained from Washington County’s travel demand model. The resulting trip distribution pattern is also shown in Figure 1.

PROPORTIONATE SHARE IMPACT

City staff requested a proportional impact analysis for the project based on the proposed trip generation and distribution for the site at the May 30, 2012 preliminary project meeting with the City of Tualatin. To complete this analysis, regionally significant traffic counts used in the on-going Tualatin Transportation System Plan Update were reused. The resulting proportional impact of the net new site-generate trips at each regionally significant intersection is illustrated in Figure 3. Based on these findings, we request that City, County, and ODOT staff review these impacts and confirm the need to study the remaining list of intersections not previously identified earlier in this memorandum.

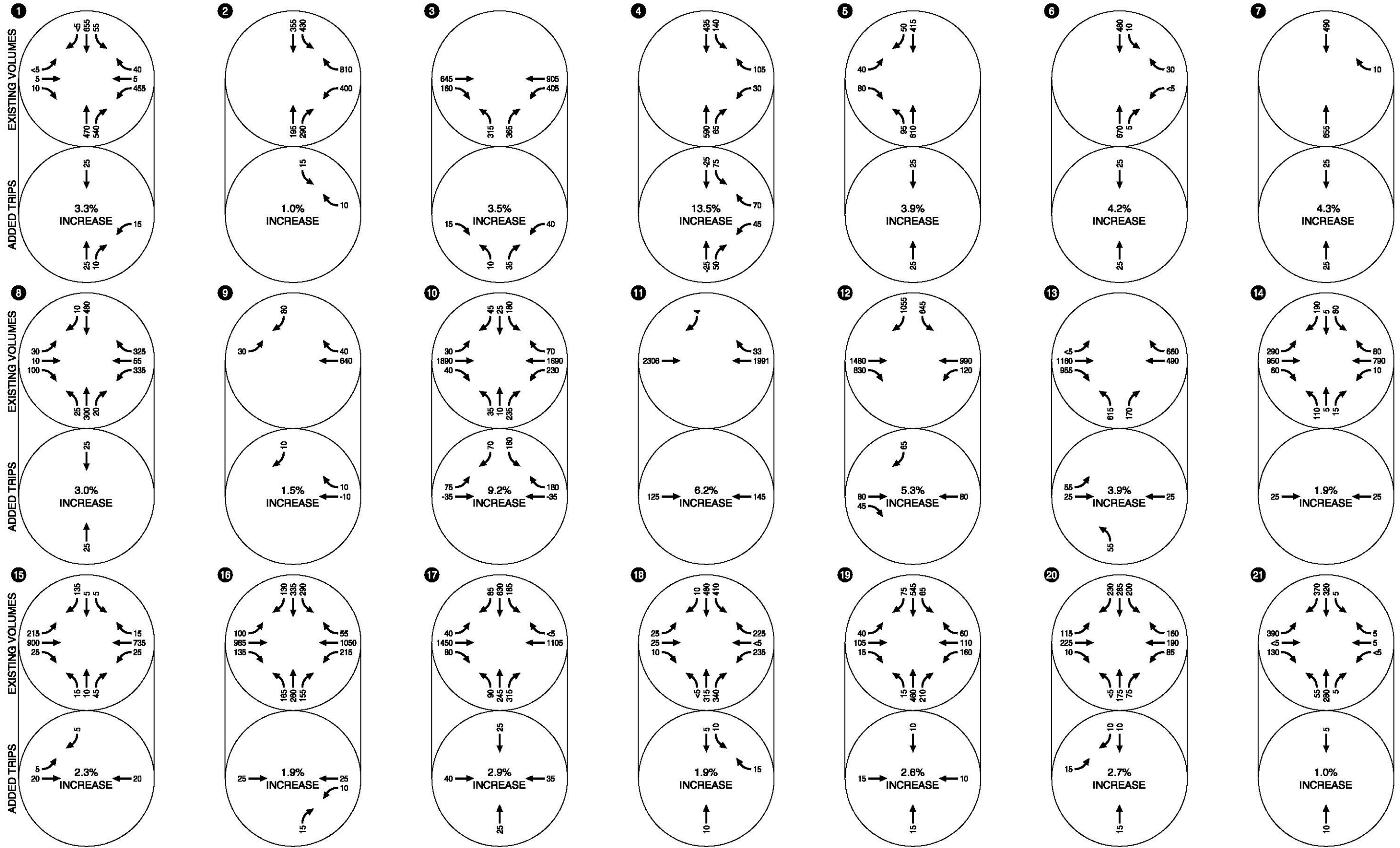

NOTE: SEE FIGURE 1 FOR LEGEND

PROPORTIONAL SHARE IMPACT
SITE GENERATED TRIPS - WEEKDAY PM PEAK HOUR
TUALATIN, OREGON

FIGURE
3

H:\proj\12116 - Nyberg Woods\dwg\figs\Fig01.dwg Aug 16, 2012 - 6:46pm - zclark Layout Tab: Fig03

We trust that this memorandum provide adequate documentation of the proposed development plan, study intersections, analysis scenarios, and estimated trip generation. We formally request that the City of Tualatin, Washington County, and ODOT provide written confirmation regarding the proposed methodology and project assumptions as soon as possible. If you have any questions, please give us a call at (503)228-5230.

Appendix A
Trip Generation
Methodology

PROPOSED TRIP GENERATION METHODOLOGY

The proposed project is only a partial redevelopment of the larger shopping center. In order to avoid overestimating the trip generation characteristics of the net new retail uses, the following trip generation methodology is proposed:

- Traffic counts were conducted at all of the site driveways to quantify the trip generation profile of the existing retail and civic uses currently operating on the site.
- Recognizing that the City offices/library are not retail uses and the layout of the site/parking fields prevents a accurate quantification of trips being generated by these uses, estimates were developed using the standard reference manual, *Trip Generation*. The Library and Single Tenant Office Building land uses were used in the estimate process. The resulting estimates were then subtracted from the existing site driveway counts to produce a trip profile estimate for the existing 158,343 square feet of retail building space at the site.
- A trip generation rate was calculated using the Shopping Center land use in *ITE Trip Generation* for the 208,180 square feet of new retail use plus the 56,744 square feet of remaining retail uses (158,343 square feet of existing retail minus 96,799 square foot K-Mart and 4,800 square foot adult cabaret). A separate estimate for the 30,000 square foot of office use was also prepared.
- The existing site retail traffic estimate was then subtracted from the total shopping center and office trip generation estimate to arrive at a total trip estimate for the net increase in shopping center and office square footage. A pass-by rate reduction of 34% was assumed for the shopping center component to generate the Net New Trip estimate for the site.

Table 2 below illustrates the trip generation calculation process.

Table 2 Trip Generation Estimate

	ITE Code	Size (sq. ft.)	Weekday PM Peak Hour			Saturday Midday Peak Hour		
			Total	In	Out	Total	In	Out
Existing Site								
Existing Site Driveways ¹	-	-	945	435	510	970	490	480
Less Existing Library ²	590	22,123	(160)	(75)	(85)	(150)	(80)	(70)
Less Existing Civic Uses ³	715	~10,000	(50)	(10)	(40)	-	-	-
Total Existing Retail			735	350	385	820	410	410
Future Site								
Shopping Center	820	264,924 ⁴	1,225	600	625	1,615	840	775
Less Existing Retail Driveway Counts	-	-	(735)	(350)	(385)	(820)	(410)	(410)
Sub Total	-	-	490	250	240	795	430	365
Pass-by Trips (Weekday 34%, Sat. 26%)	-	-	(160)	(80)	(80)	(190)	(95)	(95)
Office	710	30,000	45	10	35	10	5	5
Net New Trips			375	180	195	615	340	275

¹Represents the total site driveway counts during the weekday p.m. peak hour of 4:35-5:35 p.m. and Saturday midday peak hour of 12:10-1:10 p.m. This is the traffic volume being generated by the existing 158,343 square feet of shopping center currently residing on the site.

²The library traffic counts were estimated using the *Library* land use in ITE Trip Generation.

³The City Hall traffic counts were estimated using the *Single Tenant Office Building* land use in ITE Trip Generation. The existing City Hall square footage was estimated to be approximately 10,000 square feet in size.

⁴Includes the 158,343 square feet of existing shopping center (minus the 96,799 square foot K-Mart and 4,800 square foot adult cabaret) plus the 208,180 square feet of proposed shopping center uses.

As shown in Table 2, the combined 264,180 square feet of shopping center use is estimated to generate 1,225 weekday p.m. peak hour trips and 1,615 Saturday midday peak hour trips, respectfully. To check the validity of this methodology, weekday p.m. and Saturday midday peak hour traffic counts were taken at the previously developed 215,000 square foot Nyberg Woods shopping center on the east side of I-5. Based on these counts, it was determined that this shopping center is generating approximately 3.76 trips/1,000 square feet during the weekday p.m. peak hour and 4.76 trips/1,000 square feet during the Saturday midday peak period. Applying these rates to proposed addition of 208,180 square feet of new retail space indicates that the proposed trip generation methodology is consistent with or more conservative than actual trip generation observations at similar retail centers.

Appendix B
Traffic Count Data

LOCATION: SW Martinazzi Ave -- SW Boones Ferry Rd
CITY/STATE: Tualatin, OR

QC JOB #: 10772125
DATE: Tue, Jun 05 2012

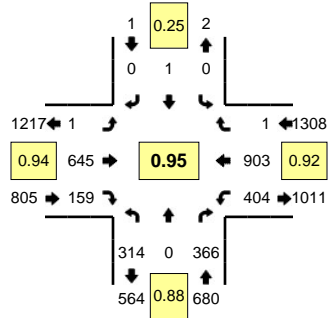

Peak-Hour: 4:35 PM -- 5:35 PM
Peak 15-Min: 5:00 PM -- 5:15 PM

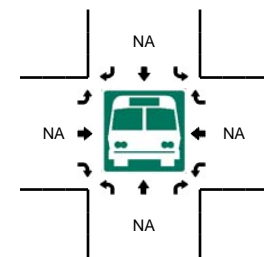
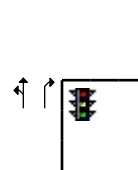
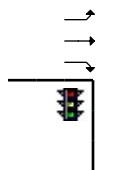
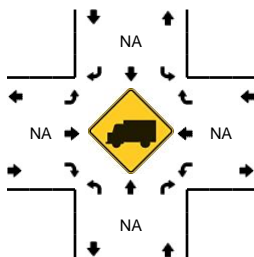
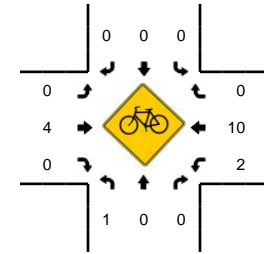
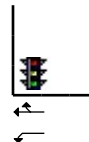
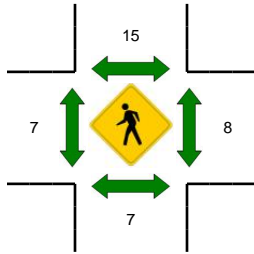
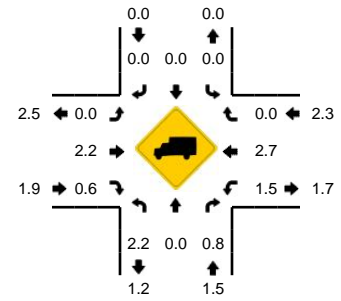

5-Min Count Period Beginning At	SW Martinazzi Ave (Northbound)				SW Martinazzi Ave (Southbound)				SW Boones Ferry Rd (Eastbound)				SW Boones Ferry Rd (Westbound)				Total	Hourly Totals
	Left	Thru	Right	U	Left	Thru	Right	U	Left	Thru	Right	U	Left	Thru	Right	U		
4:00 PM	27	0	11	0	0	0	0	0	0	57	12	0	25	70	0	0	202	2305
4:05 PM	27	0	38	0	0	0	0	0	0	61	16	0	21	64	0	0	227	2346
4:10 PM	32	0	29	0	0	0	0	0	1	48	15	0	26	70	0	0	221	2370
4:15 PM	29	0	38	0	0	0	0	0	0	59	8	0	30	81	0	0	245	2431
4:20 PM	27	0	28	0	0	0	0	0	0	53	12	0	24	67	0	0	211	2464
4:25 PM	38	0	30	0	0	0	0	0	0	40	13	0	26	64	0	0	211	2509
4:30 PM	17	0	16	0	0	0	0	0	0	49	12	0	32	76	0	0	202	2516
4:35 PM	39	0	40	0	0	0	0	0	0	50	12	0	19	65	0	0	225	2545
4:40 PM	22	0	27	0	0	1	0	0	0	47	15	0	35	90	0	0	237	2583
4:45 PM	23	0	30	0	0	0	0	0	0	53	16	0	33	74	1	0	230	2599
4:50 PM	20	0	19	0	0	0	0	0	1	64	14	0	30	81	0	0	229	2622
4:55 PM	28	0	21	0	0	0	0	0	0	52	15	0	29	70	0	0	215	2655
5:00 PM	26	0	41	0	0	0	0	0	0	54	12	0	36	75	0	0	244	2697
5:05 PM	25	0	42	0	0	0	0	0	0	44	9	0	43	81	0	0	244	2714
5:10 PM	29	0	30	0	0	0	0	0	0	56	15	0	41	79	0	0	250	2743
5:15 PM	25	0	33	0	0	0	0	0	0	59	15	0	28	78	0	0	238	2736
5:20 PM	23	0	33	0	0	0	0	0	0	51	10	0	42	78	0	0	237	2762
5:25 PM	25	0	25	0	0	0	0	0	0	60	14	0	38	66	0	0	228	2779
5:30 PM	29	0	25	0	0	0	0	0	0	55	12	0	30	66	0	0	217	2794
5:35 PM	35	0	32	0	0	0	0	0	0	45	12	0	30	73	1	0	228	2797
5:40 PM	28	0	26	0	0	0	0	0	0	42	12	0	31	76	0	0	215	2775
5:45 PM	36	0	22	0	0	0	1	0	0	39	12	0	30	75	0	0	215	2760
5:50 PM	26	0	23	0	0	0	0	0	0	42	5	0	31	81	0	0	208	2739
5:55 PM	28	0	24	0	0	0	0	0	0	32	9	0	24	61	0	0	178	2702
Peak 15-Min Flowrates	Northbound				Southbound				Eastbound				Westbound				Total	
	Left	Thru	Right	U	Left	Thru	Right	U	Left	Thru	Right	U	Left	Thru	Right	U		
All Vehicles	320	0	452	0	0	0	0	0	0	616	144	0	480	940	0	0	2952	
Heavy Trucks	4	0	0	0	0	0	0	0	0	8	0	0	8	8	0	0	28	
Pedestrians		4				12				8				12			36	
Bicycles	1	0	0	0	0	0	0	0	0	1	0	0	0	2	0	0	4	
Railroad																		
Stopped Buses																		

Comments: N

LOCATION: SW Martinazzi Ave -- Existing Site Dwy near City Hall
CITY/STATE: Tualatin, OR

QC JOB #: 10772123
DATE: Tue, Jun 05 2012

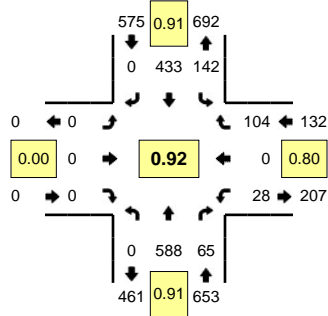

Peak-Hour: 4:35 PM -- 5:35 PM
Peak 15-Min: 5:00 PM -- 5:15 PM

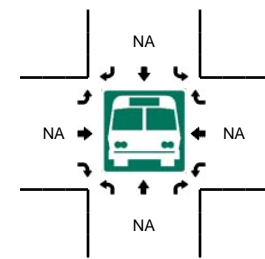
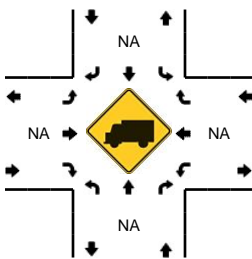
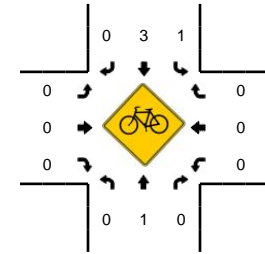
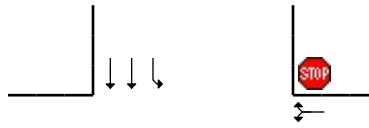
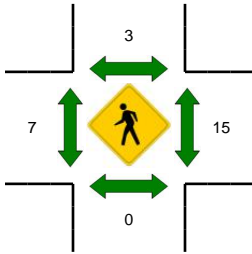
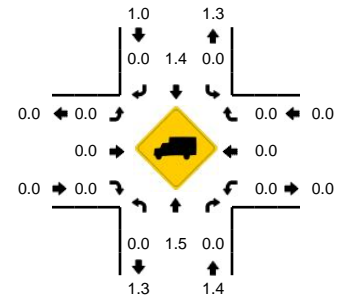

5-Min Count Period Beginning At	SW Martinazzi Ave (Northbound)				SW Martinazzi Ave (Southbound)				Existing Site Dwy near City Hall (Eastbound)				Existing Site Dwy near City Hall (Westbound)				Total	Hourly Totals
	Left	Thru	Right	U	Left	Thru	Right	U	Left	Thru	Right	U	Left	Thru	Right	U		
4:00 PM	0	39	8	0	14	30	0	0	0	0	0	0	3	0	8	0	102	1149
4:05 PM	0	57	6	0	14	18	0	0	0	0	0	0	3	0	11	0	109	1166
4:10 PM	0	54	5	0	8	30	0	0	0	0	0	0	5	0	14	0	116	1192
4:15 PM	0	50	3	0	13	34	0	0	0	0	0	0	1	0	9	0	110	1208
4:20 PM	0	42	9	0	11	25	0	0	0	0	0	0	4	0	6	0	97	1210
4:25 PM	0	48	7	0	11	26	0	0	0	0	0	0	2	0	14	0	108	1226
4:30 PM	0	37	8	0	12	32	0	0	0	0	0	0	4	0	5	0	98	1228
4:35 PM	0	58	3	0	13	27	0	0	0	0	0	0	3	0	18	0	122	1252
4:40 PM	0	47	5	0	15	35	0	0	0	0	0	0	0	0	10	0	112	1275
4:45 PM	0	37	5	0	12	40	0	0	0	0	0	0	0	0	8	0	102	1283
4:50 PM	0	42	6	0	10	37	0	0	0	0	0	0	2	0	11	0	108	1276
4:55 PM	0	50	3	0	14	27	0	0	0	0	0	0	2	0	9	0	105	1289
5:00 PM	0	54	5	0	13	43	0	0	0	0	0	0	4	0	9	0	128	1315
5:05 PM	0	47	7	0	7	40	0	0	0	0	0	0	3	0	14	0	118	1324
5:10 PM	0	59	7	0	14	41	0	0	0	0	0	0	0	0	1	0	122	1330
5:15 PM	0	49	10	0	14	30	0	0	0	0	0	0	3	0	8	0	114	1334
5:20 PM	0	44	6	0	11	38	0	0	0	0	0	0	2	0	8	0	109	1346
5:25 PM	0	52	4	0	10	40	0	0	0	0	0	0	4	0	3	0	113	1351
5:30 PM	0	49	4	0	9	35	0	0	0	0	0	0	5	0	5	0	107	1360
5:35 PM	0	57	5	0	9	32	0	0	0	0	0	0	2	0	5	0	110	1348
5:40 PM	0	46	6	0	9	35	0	0	0	0	0	0	4	0	10	0	110	1346
5:45 PM	0	48	4	0	4	35	0	0	0	0	0	0	5	0	7	0	103	1347
5:50 PM	0	47	4	0	6	39	0	0	0	0	0	0	3	0	5	0	104	1343
5:55 PM	0	44	3	0	9	20	0	0	0	0	0	0	0	0	7	0	83	1321
Peak 15-Min Flowrates	Northbound				Southbound				Eastbound				Westbound				Total	
	Left	Thru	Right	U	Left	Thru	Right	U	Left	Thru	Right	U	Left	Thru	Right	U		
All Vehicles	0	640	76	0	136	496	0	0	0	0	0	0	28	0	96	0	1472	
Heavy Trucks	0	4	0	0	0	4	0	0	0	0	0	0	0	0	0	0	8	
Pedestrians		0				0				4				12			16	
Bicycles	0	0	0		0	1	0		0	0	0		0	0	0		1	
Railroad																		
Stopped Buses																		

Comments: N

LOCATION: SW Martinazzi Ave -- SW Seneca St
CITY/STATE: Tualatin, OR

QC JOB #: 10772121
DATE: Tue, Jun 05 2012

Peak-Hour: 4:35 PM -- 5:35 PM
Peak 15-Min: 5:00 PM -- 5:15 PM

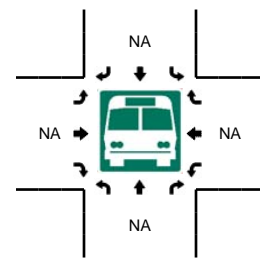
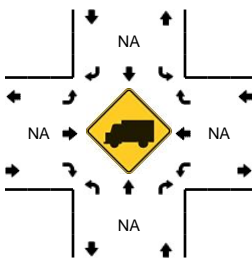
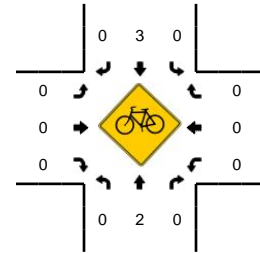
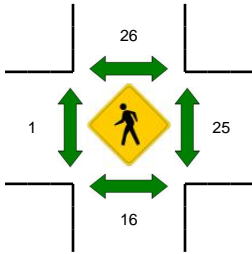
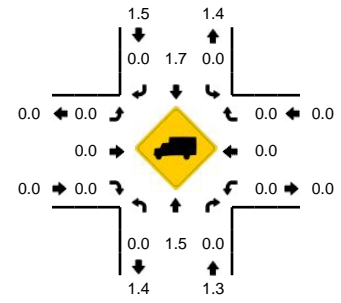
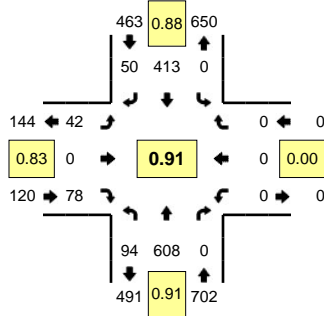

5-Min Count Period Beginning At	SW Martinazzi Ave (Northbound)				SW Martinazzi Ave (Southbound)				SW Seneca St (Eastbound)				SW Seneca St (Westbound)				Total	Hourly Totals
	Left	Thru	Right	U	Left	Thru	Right	U	Left	Thru	Right	U	Left	Thru	Right	U		
4:00 PM	6	43	0	0	0	24	7	0	2	0	5	0	0	0	0	0	87	1076
4:05 PM	6	66	0	0	0	25	2	0	3	0	9	0	0	0	0	0	111	1101
4:10 PM	11	46	0	0	0	29	4	0	3	0	5	0	0	0	0	0	98	1109
4:15 PM	7	57	0	0	0	32	1	0	2	0	6	0	0	0	0	0	105	1130
4:20 PM	7	43	0	0	0	22	5	0	5	0	5	0	0	0	0	0	87	1128
4:25 PM	10	56	0	0	0	31	1	0	3	0	3	0	0	0	0	0	104	1140
4:30 PM	9	36	0	0	0	34	3	0	3	0	1	0	0	0	0	0	86	1130
4:35 PM	6	62	0	0	0	27	1	0	3	0	7	0	0	0	0	0	106	1153
4:40 PM	9	47	0	0	0	30	5	0	2	0	10	0	0	0	0	0	103	1174
4:45 PM	10	45	0	0	0	41	1	0	3	0	4	0	0	0	0	0	104	1186
4:50 PM	1	45	0	0	0	30	5	0	4	0	10	0	0	0	0	0	95	1179
4:55 PM	9	48	0	0	0	32	5	0	1	0	7	0	0	0	0	0	102	1188
5:00 PM	12	60	0	0	0	38	5	0	1	0	6	0	0	0	0	0	122	1223
5:05 PM	7	56	0	0	0	46	1	0	2	0	9	0	0	0	0	0	121	1233
5:10 PM	5	53	0	0	0	37	5	0	6	0	4	0	0	0	0	0	110	1245
5:15 PM	8	51	0	0	0	20	3	0	7	0	8	0	0	0	0	0	97	1237
5:20 PM	9	42	0	0	0	38	5	0	7	0	1	0	0	0	0	0	102	1252
5:25 PM	12	55	0	0	0	40	7	0	3	0	3	0	0	0	0	0	120	1268
5:30 PM	6	44	0	0	0	34	7	0	3	0	9	0	0	0	0	0	103	1285
5:35 PM	10	66	0	0	0	25	6	0	2	0	7	0	0	0	0	0	116	1295
5:40 PM	9	43	0	0	0	35	4	0	5	0	10	0	0	0	0	0	106	1298
5:45 PM	5	59	0	0	0	38	4	0	2	0	7	0	0	0	0	0	115	1309
5:50 PM	6	41	0	0	0	36	5	0	2	0	3	0	0	0	0	0	93	1307
5:55 PM	3	49	0	0	0	25	2	0	4	0	1	0	0	0	0	0	84	1289
Peak 15-Min Flowrates	Northbound				Southbound				Eastbound				Westbound				Total	
All Vehicles	96	676	0	0	0	484	44	0	36	0	76	0	0	0	0	0	1412	
Heavy Trucks	0	4	0	0	0	8	0	0	0	0	0	0	0	0	0	0	12	
Pedestrians		4				20					0			8			32	
Bicycles	0	1	0	0	0	1	0	0	0	0	0	0	0	0	0	0	2	
Railroad																		
Stopped Buses																		

Comments: N

LOCATION: SW Martinazzi Ave -- Existing Site Dwy
CITY/STATE: Tualatin, OR

QC JOB #: 10772119
DATE: Tue, Jun 05 2012

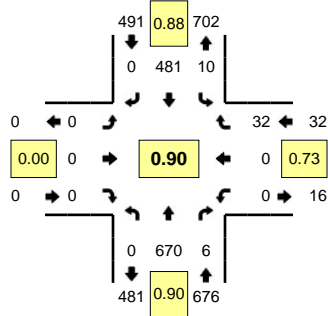

Peak-Hour: 4:35 PM -- 5:35 PM
Peak 15-Min: 5:00 PM -- 5:15 PM

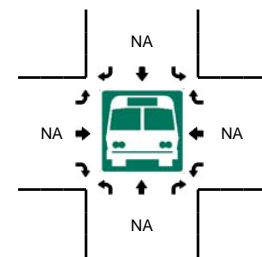
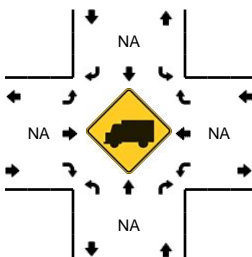
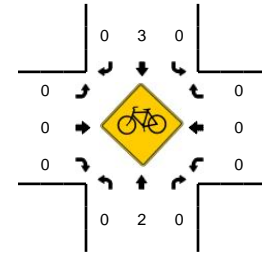
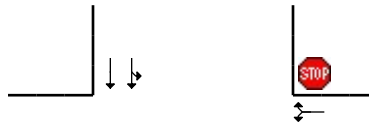
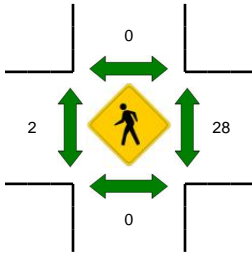
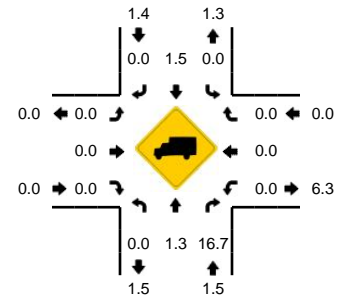

5-Min Count Period Beginning At	SW Martinazzi Ave (Northbound)				SW Martinazzi Ave (Southbound)				Existing Site Dwy (Eastbound)				Existing Site Dwy (Westbound)				Total	Hourly Totals	
	Left	Thru	Right	U	Left	Thru	Right	U	Left	Thru	Right	U	Left	Thru	Right	U			
4:00 PM	0	48	0	0	0	29	0	0	0	0	0	0	0	0	0	1	0	78	978
4:05 PM	0	72	1	0	0	34	0	0	0	0	0	0	0	1	0	0	0	108	1007
4:10 PM	0	52	0	0	1	33	0	0	0	0	0	0	0	1	0	5	0	92	1013
4:15 PM	0	63	1	0	1	37	0	0	0	0	0	0	0	0	0	1	0	103	1044
4:20 PM	0	47	0	0	2	25	0	0	0	0	0	0	0	1	0	3	0	78	1037
4:25 PM	0	62	0	0	0	34	0	0	0	0	0	0	0	1	0	4	0	101	1054
4:30 PM	0	44	0	0	0	35	0	0	0	0	0	0	0	1	0	1	0	81	1051
4:35 PM	0	61	1	0	1	33	0	0	0	0	0	0	0	0	0	7	0	103	1075
4:40 PM	0	55	0	0	1	39	0	0	0	0	0	0	0	0	0	1	0	96	1095
4:45 PM	0	54	0	0	0	45	0	0	0	0	0	0	0	0	0	1	0	100	1117
4:50 PM	0	42	1	0	1	39	0	0	0	0	0	0	0	0	0	4	0	87	1113
4:55 PM	0	55	1	0	2	37	0	0	0	0	0	0	0	0	0	2	0	97	1124
5:00 PM	0	71	0	0	0	44	0	0	0	0	0	0	0	0	0	1	0	116	1162
5:05 PM	0	59	1	0	4	51	0	0	0	0	0	0	0	0	0	4	0	119	1173
5:10 PM	0	55	0	0	1	40	0	0	0	0	0	0	0	0	0	3	0	99	1180
5:15 PM	0	55	2	0	0	28	0	0	0	0	0	0	0	0	0	4	0	89	1166
5:20 PM	0	48	0	0	0	39	0	0	0	0	0	0	0	0	0	3	0	90	1178
5:25 PM	0	66	0	0	0	43	0	0	0	0	0	0	0	0	0	1	0	110	1187
5:30 PM	0	49	0	0	0	43	0	0	0	0	0	0	0	0	0	1	0	93	1199
5:35 PM	0	74	1	0	1	31	0	0	0	0	0	0	0	0	0	2	0	109	1205
5:40 PM	0	47	0	0	2	43	0	0	0	0	0	0	0	0	0	5	0	97	1206
5:45 PM	0	62	0	0	0	45	0	0	0	0	0	0	0	0	0	2	0	109	1215
5:50 PM	0	47	1	0	0	39	0	0	0	0	0	0	0	0	0	0	0	87	1215
5:55 PM	0	52	0	0	0	26	0	0	0	0	0	0	0	0	0	0	0	78	1196
Peak 15-Min Flowrates	Northbound				Southbound				Eastbound				Westbound				Total		
	Left	Thru	Right	U	Left	Thru	Right	U	Left	Thru	Right	U	Left	Thru	Right	U			
All Vehicles	0	740	4	0	20	540	0	0	0	0	0	0	0	0	0	32	0	1336	
Heavy Trucks	0	4	0	0	0	8	0	0	0	0	0	0	0	0	0	0	0	12	
Pedestrians	0	0	0	0	0	0	0	0	0	0	0	0	0	12	0	0	0	12	
Bicycles	0	1	0	0	0	1	0	0	0	0	0	0	0	0	0	0	0	2	
Railroad																			
Stopped Buses																			

Comments: N

LOCATION: SW Martinazzi Ave -- Existing Right-Out Only Dwy
CITY/STATE: Tualatin, OR

QC JOB #: 10772117
DATE: Tue, Jun 05 2012

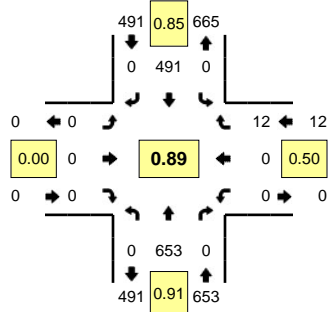

Peak-Hour: 4:35 PM -- 5:35 PM
Peak 15-Min: 5:00 PM -- 5:15 PM

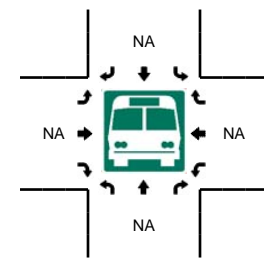
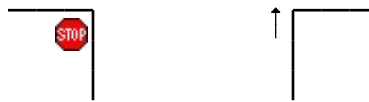
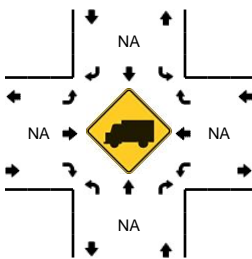
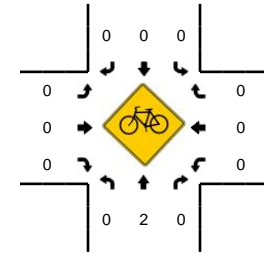
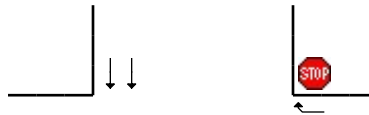
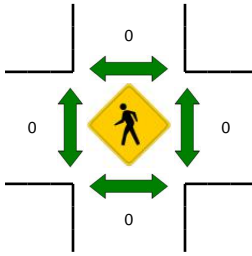
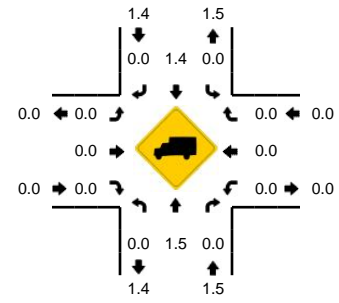

5-Min Count Period Beginning At	SW Martinazzi Ave (Northbound)				SW Martinazzi Ave (Southbound)				Existing Right-Out Only Dwy (Eastbound)				Existing Right-Out Only Dwy (Westbound)				Total	Hourly Totals
	Left	Thru	Right	U	Left	Thru	Right	U	Left	Thru	Right	U	Left	Thru	Right	U		
4:00 PM	0	51	0	0	0	28	0	0	0	0	0	0	0	0	0	0	79	962
4:05 PM	0	70	0	0	0	35	0	0	0	0	0	0	0	0	1	0	106	989
4:10 PM	0	50	0	0	0	34	0	0	0	0	0	0	0	0	0	0	84	990
4:15 PM	0	61	0	0	0	35	0	0	0	0	0	0	0	0	1	0	97	1018
4:20 PM	0	45	0	0	0	37	0	0	0	0	0	0	0	0	2	0	84	1009
4:25 PM	0	62	0	0	0	41	0	0	0	0	0	0	0	0	0	0	103	1027
4:30 PM	0	39	0	0	0	40	0	0	0	0	0	0	0	0	1	0	80	1029
4:35 PM	0	62	0	0	0	30	0	0	0	0	0	0	0	0	1	0	93	1041
4:40 PM	0	52	0	0	0	39	0	0	0	0	0	0	0	0	1	0	92	1059
4:45 PM	0	52	0	0	0	37	0	0	0	0	0	0	0	0	0	0	89	1074
4:50 PM	0	43	0	0	0	44	0	0	0	0	0	0	0	0	0	0	87	1080
4:55 PM	0	53	0	0	0	37	0	0	0	0	0	0	0	0	0	0	90	1084
5:00 PM	0	66	0	0	0	46	0	0	0	0	0	0	0	0	2	0	114	1119
5:05 PM	0	58	0	0	0	46	0	0	0	0	0	0	0	0	0	0	104	1117
5:10 PM	0	55	0	0	0	52	0	0	0	0	0	0	0	0	0	0	107	1140
5:15 PM	0	54	0	0	0	33	0	0	0	0	0	0	0	0	2	0	89	1132
5:20 PM	0	46	0	0	0	33	0	0	0	0	0	0	0	0	2	0	81	1129
5:25 PM	0	63	0	0	0	52	0	0	0	0	0	0	0	0	1	0	116	1142
5:30 PM	0	49	0	0	0	42	0	0	0	0	0	0	0	0	3	0	94	1156
5:35 PM	0	75	0	0	0	38	0	0	0	0	0	0	0	0	0	0	113	1176
5:40 PM	0	45	0	0	0	38	0	0	0	0	0	0	0	0	0	0	83	1167
5:45 PM	0	60	0	0	0	47	0	0	0	0	0	0	0	0	0	0	107	1185
5:50 PM	0	48	0	0	0	37	0	0	0	0	0	0	0	0	0	0	85	1183
5:55 PM	0	51	0	0	0	29	0	0	0	0	0	0	0	0	0	0	80	1173
Peak 15-Min Flowrates	Northbound				Southbound				Eastbound				Westbound				Total	
All Vehicles	0	716	0	0	0	576	0	0	0	0	0	0	0	0	8	0	1300	
Heavy Trucks	0	4	0	0	0	8	0	0	0	0	0	0	0	0	0	0	12	
Pedestrians	0	0	0	0	0	0	0	0	0	0	0	0	0	0	0	0	0	
Bicycles	0	1	0	0	0	0	0	0	0	0	0	0	0	0	0	0	1	
Railroad																		
Stopped Buses																		

Comments: N

LOCATION: SW Martinazzi Ave -- SW Tualatin-Sherwood Rd
CITY/STATE: Tualatin, OR

QC JOB #: 10772115
DATE: Wed, Jun 06 2012

Peak-Hour: 4:35 PM -- 5:35 PM
Peak 15-Min: 5:05 PM -- 5:20 PM

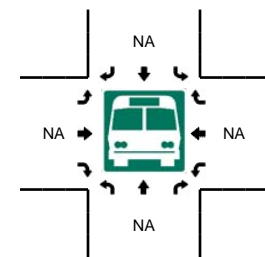
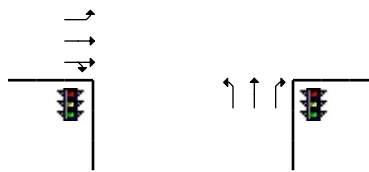
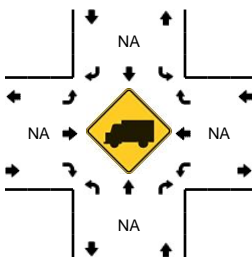
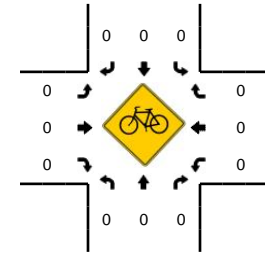
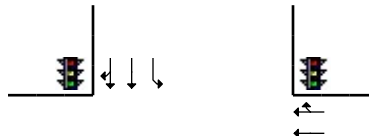
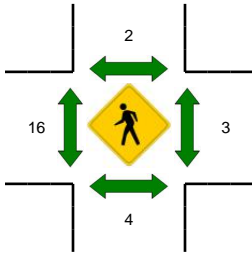
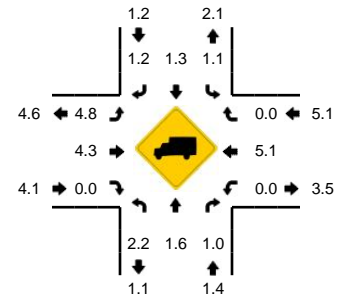
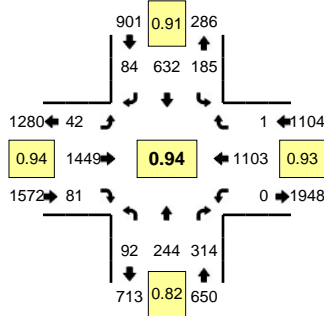

5-Min Count Period Beginning At	SW Martinazzi Ave (Northbound)				SW Martinazzi Ave (Southbound)				SW Tualatin-Sherwood Rd (Eastbound)				SW Tualatin-Sherwood Rd (Westbound)				Total	Hourly Totals
	Left	Thru	Right	U	Left	Thru	Right	U	Left	Thru	Right	U	Left	Thru	Right	U		
4:00 PM	7	23	22	0	11	42	4	0	4	116	6	0	0	86	0	0	321	3812
4:05 PM	5	16	25	0	10	42	5	0	4	109	8	0	0	119	0	0	343	3845
4:10 PM	12	28	21	0	19	45	12	0	4	90	5	0	0	86	0	0	322	3893
4:15 PM	6	16	25	0	16	39	5	0	5	141	11	0	0	106	0	0	370	3950
4:20 PM	8	13	11	0	20	38	7	0	4	129	7	0	0	77	0	0	314	3971
4:25 PM	7	23	33	0	5	58	9	0	8	114	4	0	0	83	0	0	344	4000
4:30 PM	7	13	14	0	10	30	1	0	7	140	5	0	0	104	0	0	331	3990
4:35 PM	8	27	35	0	17	71	7	0	2	100	8	0	0	79	0	0	354	4039
4:40 PM	6	22	26	0	14	37	1	0	4	141	6	1	0	130	0	0	388	4058
4:45 PM	10	17	20	0	18	32	6	0	1	112	3	0	0	73	0	0	292	4061
4:50 PM	7	11	24	0	11	48	8	0	5	119	5	0	0	94	0	0	332	4060
4:55 PM	11	18	18	0	26	53	11	0	0	109	4	0	0	69	0	0	319	4030
5:00 PM	6	22	20	0	12	45	13	0	8	127	5	0	0	84	0	0	342	4051
5:05 PM	12	22	33	0	15	45	4	0	2	127	6	0	0	103	0	0	369	4077
5:10 PM	7	34	36	0	15	78	9	0	4	116	3	0	0	78	1	0	381	4136
5:15 PM	6	25	22	0	11	43	7	0	5	133	7	0	0	111	0	0	370	4136
5:20 PM	14	16	31	0	21	57	3	0	4	119	9	0	0	93	0	0	367	4189
5:25 PM	0	17	27	0	13	83	10	0	4	123	15	0	0	91	0	0	383	4228
5:30 PM	5	13	22	0	12	40	5	0	2	123	10	0	0	98	0	0	330	4227
5:35 PM	12	19	29	0	19	66	5	0	5	59	2	0	0	94	0	0	310	4183
5:40 PM	3	3	19	0	12	37	10	0	5	124	4	0	1	97	0	0	315	4110
5:45 PM	8	17	25	0	21	51	8	0	6	79	13	0	0	79	0	0	307	4125
5:50 PM	5	24	20	0	10	42	4	0	5	78	6	0	0	139	0	0	333	4126
5:55 PM	9	18	15	1	17	50	11	0	5	80	7	0	0	69	0	0	282	4089
Peak 15-Min Flowrates	Northbound				Southbound				Eastbound				Westbound				Total	
All Vehicles	100	324	364	0	164	664	80	0	44	1504	64	0	0	1168	4	0	4480	
Heavy Trucks	0	4	4		0	4	0		4	40	0		0	68	0		124	
Pedestrians		0				4				32				0			36	
Bicycles	0	0	0		0	0	0		0	0	0		0	0	0		0	
Railroad																		
Stopped Buses																		

Comments: N

LOCATION: SW Martinazzi Ave -- SW Nyberg St
CITY/STATE: Tualatin, OR

QC JOB #: 10772113
DATE: Tue, Jun 05 2012

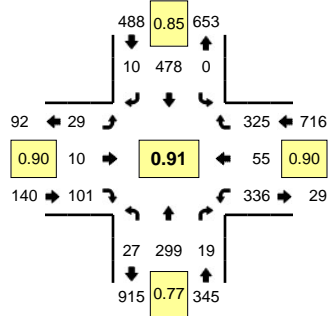

Peak-Hour: 4:35 PM -- 5:35 PM
Peak 15-Min: 5:00 PM -- 5:15 PM

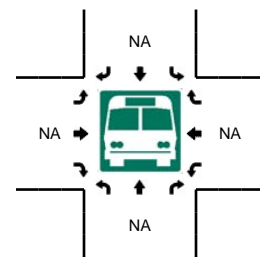
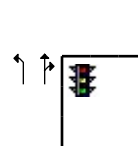
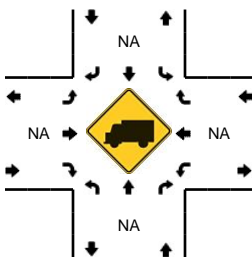
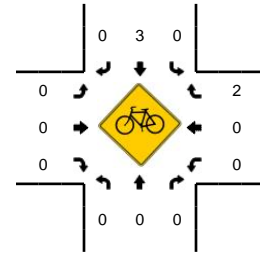
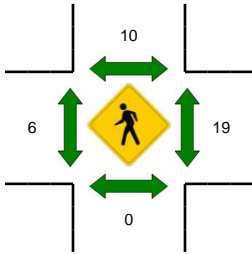
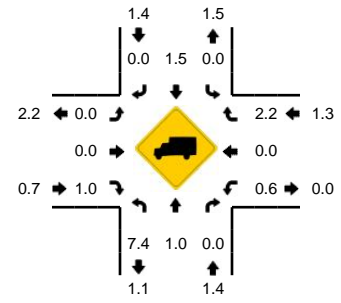

5-Min Count Period Beginning At	SW Martinazzi Ave (Northbound)				SW Martinazzi Ave (Southbound)				SW Nyberg St (Eastbound)				SW Nyberg St (Westbound)				Total	Hourly Totals
	Left	Thru	Right	U	Left	Thru	Right	U	Left	Thru	Right	U	Left	Thru	Right	U		
4:00 PM	0	20	2	0	0	27	1	0	1	2	13	0	17	3	30	0	116	1367
4:05 PM	1	27	3	0	0	32	1	0	4	0	8	0	24	2	39	0	141	1392
4:10 PM	2	26	0	0	0	36	1	0	4	0	5	0	20	5	20	0	119	1395
4:15 PM	2	31	2	0	0	30	2	0	2	0	13	0	25	3	28	0	138	1424
4:20 PM	2	18	2	0	0	36	1	0	1	1	5	0	22	3	26	0	117	1417
4:25 PM	1	28	0	0	0	32	3	0	2	0	6	0	32	3	32	0	139	1445
4:30 PM	0	13	0	0	0	33	3	0	3	1	6	0	22	2	23	0	106	1441
4:35 PM	3	32	0	0	0	34	3	0	3	2	8	0	23	2	27	0	137	1466
4:40 PM	1	25	1	0	0	36	1	0	0	0	8	0	25	3	27	0	127	1489
4:45 PM	3	22	3	0	0	41	1	0	5	2	10	0	25	5	25	0	142	1536
4:50 PM	4	15	3	0	0	41	0	0	1	0	7	0	27	6	27	0	131	1547
4:55 PM	0	21	0	0	0	34	1	0	2	0	11	0	35	5	30	0	139	1552
5:00 PM	2	35	2	0	0	47	0	0	5	1	9	0	33	7	26	0	167	1603
5:05 PM	1	30	0	0	0	42	1	0	1	1	9	0	31	6	27	0	149	1611
5:10 PM	5	33	4	0	0	54	0	0	1	3	9	0	14	2	21	0	146	1638
5:15 PM	1	20	1	0	0	33	1	0	2	0	6	0	27	7	32	0	130	1630
5:20 PM	2	21	2	0	0	31	0	0	3	1	8	0	26	1	22	0	117	1630
5:25 PM	1	27	2	0	0	50	1	0	4	0	10	0	32	6	32	0	165	1656
5:30 PM	4	18	1	0	0	35	1	0	2	0	6	0	38	5	29	0	139	1689
5:35 PM	3	40	1	0	0	45	1	0	6	0	8	0	24	6	29	0	163	1715
5:40 PM	0	17	2	0	0	36	2	0	1	0	6	0	23	1	27	0	115	1703
5:45 PM	2	24	2	0	0	48	0	0	2	0	7	0	32	4	34	0	155	1716
5:50 PM	1	15	2	0	0	36	2	0	1	0	6	0	31	1	32	0	127	1712
5:55 PM	2	17	0	0	0	26	1	0	1	2	12	0	31	4	33	0	129	1702
Peak 15-Min Flowrates	Northbound				Southbound				Eastbound				Westbound				Total	
	Left	Thru	Right	U	Left	Thru	Right	U	Left	Thru	Right	U	Left	Thru	Right	U		
All Vehicles	32	392	24	0	0	572	4	0	28	20	108	0	312	60	296	0	1848	
Heavy Trucks	0	0	0	0	0	12	0	0	0	0	0	0	4	0	4	0	20	
Pedestrians		0				8				0				16			24	
Bicycles	0	0	0	0	0	1	0	0	0	0	0	0	0	0	1	0	2	
Railroad																		
Stopped Buses																		

Comments: N

LOCATION: Unsignalized Site Dwy -- SW Nyberg St
CITY/STATE: Tualatin, OR

QC JOB #: 10772111
DATE: Tue, Jun 05 2012

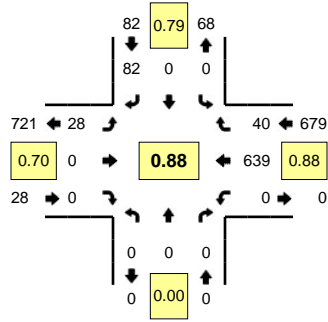

Peak-Hour: 4:35 PM -- 5:35 PM
Peak 15-Min: 4:50 PM -- 5:05 PM

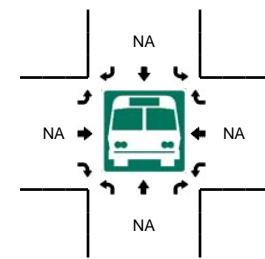
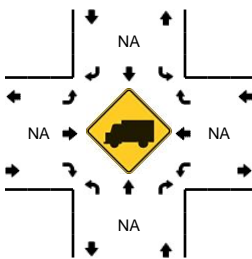
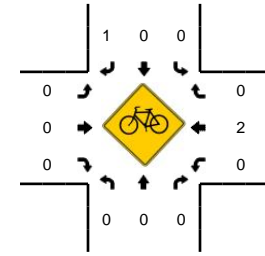
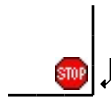
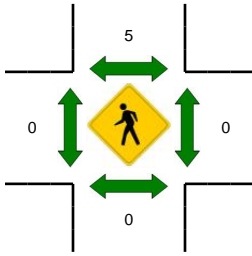
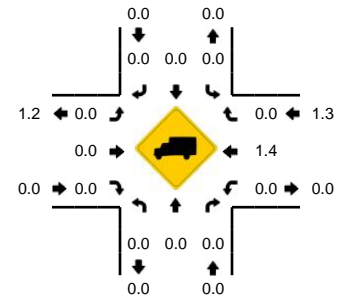

5-Min Count Period Beginning At	Unsignalized Site Dwy (Northbound)				Unsignalized Site Dwy (Southbound)				SW Nyberg St (Eastbound)				SW Nyberg St (Westbound)				Total	Hourly Totals
	Left	Thru	Right	U	Left	Thru	Right	U	Left	Thru	Right	U	Left	Thru	Right	U		
4:00 PM	0	0	0	0	0	0	3	0	4	0	0	0	0	48	5	0	60	668
4:05 PM	0	0	0	0	0	0	13	0	3	0	0	0	0	51	5	0	72	696
4:10 PM	0	0	0	0	0	0	3	0	1	0	0	0	0	53	3	0	60	700
4:15 PM	0	0	0	0	0	0	7	0	1	0	0	0	0	46	1	0	55	700
4:20 PM	0	0	0	0	0	0	5	0	4	0	0	0	0	43	2	0	54	699
4:25 PM	0	0	0	0	0	0	4	0	0	0	0	0	0	65	2	0	71	715
4:30 PM	0	0	0	0	0	0	3	0	1	0	0	0	0	45	7	0	56	722
4:35 PM	0	0	0	0	0	0	5	0	2	0	0	0	0	53	3	0	63	729
4:40 PM	0	0	0	0	0	0	8	0	1	0	0	0	0	40	3	0	52	729
4:45 PM	0	0	0	0	0	0	6	0	4	0	0	0	0	41	5	0	56	724
4:50 PM	0	0	0	0	0	0	7	0	3	0	0	0	0	62	4	0	76	736
4:55 PM	0	0	0	0	0	0	12	0	1	0	0	0	0	47	5	0	65	740
5:00 PM	0	0	0	0	0	0	7	0	3	0	0	0	0	72	2	0	84	764
5:05 PM	0	0	0	0	0	0	6	0	0	0	0	0	0	46	0	0	52	744
5:10 PM	0	0	0	0	0	0	2	0	6	0	0	0	0	53	8	0	69	753
5:15 PM	0	0	0	0	0	0	4	0	1	0	0	0	0	53	1	0	59	757
5:20 PM	0	0	0	0	0	0	7	0	3	0	0	0	0	39	3	0	52	755
5:25 PM	0	0	0	0	0	0	7	0	3	0	0	0	0	74	3	0	87	771
5:30 PM	0	0	0	0	0	0	11	0	1	0	0	0	0	59	3	0	74	789
5:35 PM	0	0	0	0	0	0	3	0	2	0	0	0	0	56	5	0	66	792
5:40 PM	0	0	0	0	0	0	5	0	2	0	0	0	0	53	4	0	64	804
5:45 PM	0	0	0	0	0	0	5	0	0	0	0	0	0	62	2	0	69	817
5:50 PM	0	0	0	0	0	0	3	0	2	0	0	0	0	68	6	0	79	820
5:55 PM	0	0	0	0	0	0	6	0	0	0	0	0	0	45	3	0	54	809
Peak 15-Min Flowrates	Northbound				Southbound				Eastbound				Westbound				Total	
	Left	Thru	Right	U	Left	Thru	Right	U	Left	Thru	Right	U	Left	Thru	Right	U		
All Vehicles	0	0	0	0	0	0	104	0	28	0	0	0	0	724	44	0	900	
Heavy Trucks	0	0	0	0	0	0	0	0	0	0	0	0	0	12	0	0	12	
Pedestrians							4							0			4	
Bicycles	0	0	0	0	0	0	0	0	0	0	0	0	0	1	0	0	1	
Railroad																		
Stopped Buses																		

Comments: N

LOCATION: Fred Meyer/Site Dwy -- SW Nyberg St/SW Tualatin-Sherwood Rd
CITY/STATE: Tualatin, OR

QC JOB #: 10772109
DATE: Tue, Jun 05 2012

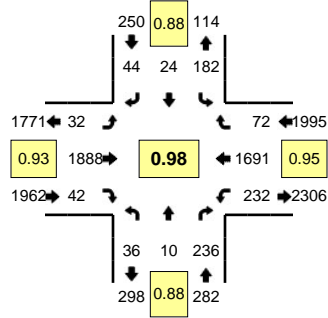

Peak-Hour: 4:35 PM -- 5:35 PM
Peak 15-Min: 5:20 PM -- 5:35 PM

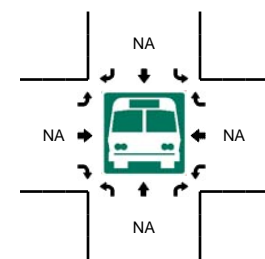
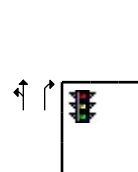
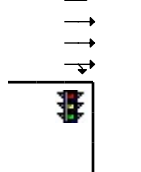
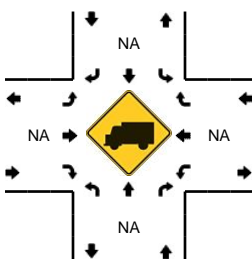
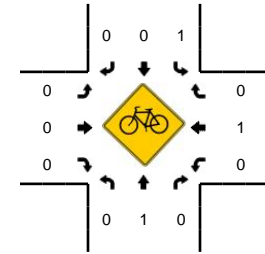
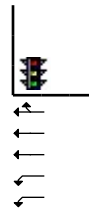
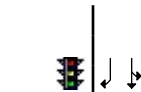
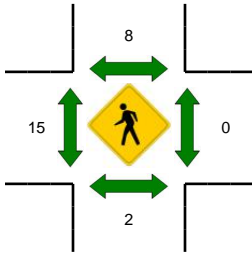
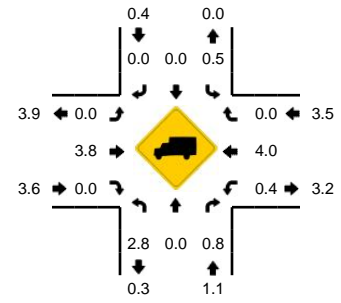

5-Min Count Period Beginning At	Fred Meyer/Site Dwy (Northbound)				Fred Meyer/Site Dwy (Southbound)				SW Nyberg St/SW Tualatin-Sherwood Rd (Eastbound)				SW Nyberg St/SW Tualatin-Sherwood Rd (Westbound)				Total	Hourly Totals
	Left	Thru	Right	U	Left	Thru	Right	U	Left	Thru	Right	U	Left	Thru	Right	U		
4:00 PM	5	3	15	0	15	1	1	0	1	133	0	0	16	115	6	0	311	4116
4:05 PM	4	0	20	0	15	1	7	0	1	178	0	0	12	137	9	0	384	4156
4:10 PM	2	3	25	0	19	3	3	0	1	124	8	0	26	133	6	0	353	4151
4:15 PM	2	2	26	0	9	5	6	0	1	176	9	0	23	150	6	0	415	4256
4:20 PM	4	5	27	0	6	4	3	0	6	133	0	1	28	138	11	0	366	4255
4:25 PM	2	1	17	0	26	1	6	0	4	140	3	0	12	134	13	0	359	4289
4:30 PM	3	0	15	0	7	2	2	0	1	180	8	0	16	162	5	0	401	4351
4:35 PM	4	1	27	0	19	2	4	0	3	134	2	0	26	117	11	0	350	4340
4:40 PM	1	2	16	0	7	0	2	0	5	185	5	0	7	168	4	0	402	4386
4:45 PM	2	2	24	0	19	2	3	0	2	143	4	0	24	123	5	0	353	4422
4:50 PM	3	3	16	0	15	2	2	0	5	176	2	0	13	145	5	0	387	4406
4:55 PM	2	0	26	0	15	1	3	0	2	149	2	0	21	150	6	0	377	4458
5:00 PM	7	0	23	0	20	3	3	0	5	155	2	0	14	137	4	0	373	4520
5:05 PM	0	0	17	0	16	3	3	0	2	162	1	0	19	135	5	0	363	4499
5:10 PM	2	1	23	0	12	2	3	0	1	155	5	0	27	150	3	0	384	4530
5:15 PM	0	1	10	0	13	2	3	0	2	162	5	0	16	132	5	0	351	4466
5:20 PM	5	0	25	0	13	2	4	0	0	141	3	0	22	137	7	0	359	4459
5:25 PM	7	0	16	0	20	4	10	0	1	144	4	0	17	143	10	0	376	4476
5:30 PM	3	0	13	0	13	1	4	0	4	182	7	0	26	154	7	0	414	4489
5:35 PM	1	1	17	0	12	2	5	0	0	124	3	0	26	138	6	0	335	4474
5:40 PM	1	2	11	0	16	0	2	0	5	156	5	0	17	163	8	0	386	4458
5:45 PM	3	1	18	0	16	2	0	0	2	132	5	1	26	164	5	0	375	4480
5:50 PM	4	3	11	0	8	6	6	0	4	117	2	0	9	155	3	0	328	4421
5:55 PM	2	1	19	0	5	1	4	0	2	126	4	0	26	135	6	0	331	4375
Peak 15-Min Flowrates	Northbound				Southbound				Eastbound				Westbound				Total	
	Left	Thru	Right	U	Left	Thru	Right	U	Left	Thru	Right	U	Left	Thru	Right	U		
All Vehicles	60	0	216	0	184	28	72	0	20	1868	56	0	260	1736	96	0	4596	
Heavy Trucks	0	0	0		0	0	0		0	112	0		0	60	0		172	
Pedestrians						24				28				0			52	
Bicycles	0	0	0		0	0	0		0	0	0		0	0	0		0	
Railroad																		
Stopped Buses																		

Comments: N

LOCATION: SW 75th Ave -- SW Nyberg St
CITY/STATE: Tualatin, OR

QC JOB #: 10772107
DATE: Tue, Jun 05 2012

Peak-Hour: 4:35 PM -- 5:35 PM
Peak 15-Min: 4:50 PM -- 5:05 PM

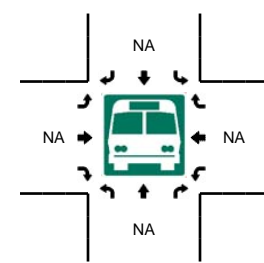
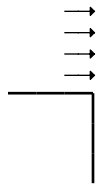
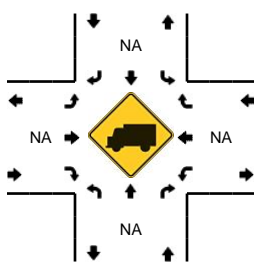
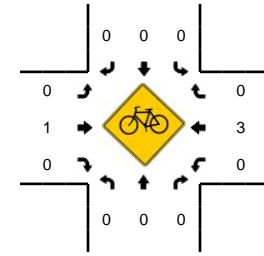
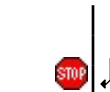
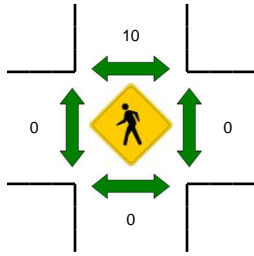
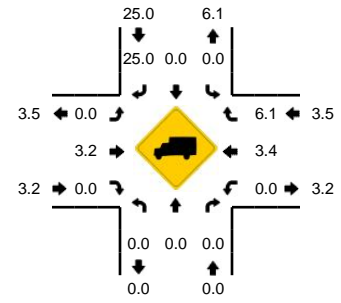
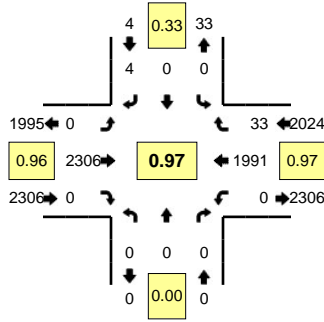

5-Min Count Period Beginning At	SW 75th Ave (Northbound)				SW 75th Ave (Southbound)				SW Nyberg St (Eastbound)				SW Nyberg St (Westbound)				Total	Hourly Totals
	Left	Thru	Right	U	Left	Thru	Right	U	Left	Thru	Right	U	Left	Thru	Right	U		
4:00 PM	0	0	0	0	0	0	1	0	0	163	0	0	0	149	5	0	318	4008
4:05 PM	0	0	0	0	0	0	1	0	0	213	0	0	0	149	6	0	369	4056
4:10 PM	0	0	0	0	0	0	0	0	0	168	0	0	0	177	9	0	354	4060
4:15 PM	0	0	0	0	0	0	0	0	0	211	0	0	0	167	5	0	383	4136
4:20 PM	0	0	0	0	0	0	0	0	0	166	0	0	0	164	3	0	333	4126
4:25 PM	0	0	0	0	0	0	1	0	0	183	0	0	0	184	1	0	369	4172
4:30 PM	0	0	0	0	0	0	0	0	0	202	0	0	0	170	1	0	373	4213
4:35 PM	0	0	0	0	0	0	0	0	0	180	0	0	0	181	1	0	362	4218
4:40 PM	0	0	0	0	0	0	0	0	0	208	0	0	0	156	4	0	368	4257
4:45 PM	0	0	0	0	0	0	0	0	0	186	0	0	0	153	5	0	344	4266
4:50 PM	0	0	0	0	0	0	0	0	0	207	0	0	0	171	4	0	382	4259
4:55 PM	0	0	0	0	0	0	1	0	0	190	0	0	0	174	2	0	367	4322
5:00 PM	0	0	0	0	0	0	1	0	0	198	0	0	0	167	3	0	369	4373
5:05 PM	0	0	0	0	0	0	1	0	0	195	0	0	0	153	2	0	351	4355
5:10 PM	0	0	0	0	0	0	0	0	0	190	0	0	0	169	5	0	364	4365
5:15 PM	0	0	0	0	0	0	0	0	0	185	0	0	0	158	4	0	347	4329
5:20 PM	0	0	0	0	0	0	1	0	0	179	0	0	0	152	1	0	333	4329
5:25 PM	0	0	0	0	0	0	0	0	0	180	0	0	0	171	1	0	352	4312
5:30 PM	0	0	0	0	0	0	0	0	0	208	0	0	0	186	1	0	395	4334
5:35 PM	0	0	0	0	0	0	0	0	0	153	0	0	0	167	4	0	324	4296
5:40 PM	0	0	0	0	0	0	0	0	0	183	0	0	0	180	6	0	369	4297
5:45 PM	0	0	0	0	0	0	2	0	0	166	0	0	0	196	5	0	369	4322
5:50 PM	0	0	0	0	0	0	0	0	0	136	0	0	0	168	2	0	306	4246
5:55 PM	0	0	0	0	0	0	0	0	0	150	0	0	0	163	2	0	315	4194
Peak 15-Min Flowrates	Northbound				Southbound				Eastbound				Westbound				Total	
	Left	Thru	Right	U	Left	Thru	Right	U	Left	Thru	Right	U	Left	Thru	Right	U		
All Vehicles	0	0	0	0	0	0	8	0	0	2380	0	0	0	2048	36	0	4472	
Heavy Trucks	0	0	0	0	0	0	0	0	0	72	0	0	0	84	0	0	156	
Pedestrians						4				0				0			4	
Bicycles	0	0	0	0	0	0	0	0	0	1	0	0	0	1	0	0	2	
Railroad																		
Stopped Buses																		

Comments: N

LOCATION: I-5 SB Ramp Terminal -- SW Nyberg St
CITY/STATE: Tualatin, OR

QC JOB #: 10772105
DATE: Tue, Jun 05 2012

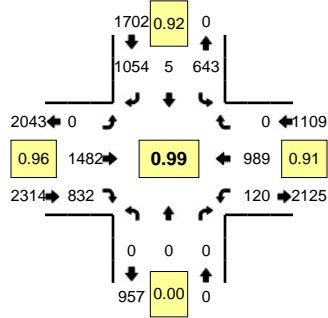

Peak-Hour: 4:35 PM -- 5:35 PM
Peak 15-Min: 5:20 PM -- 5:35 PM

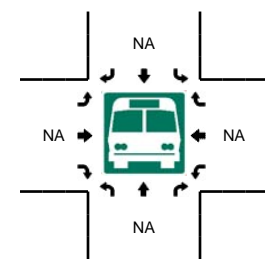
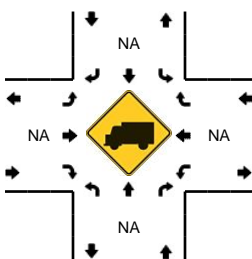
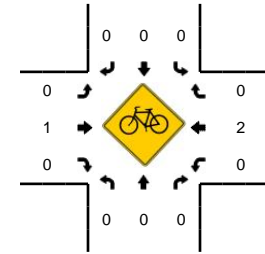
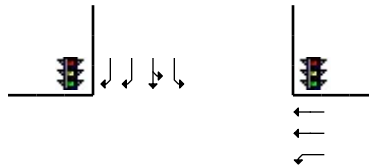
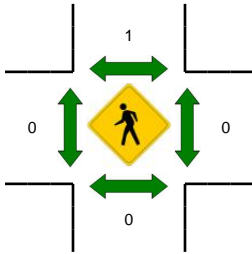
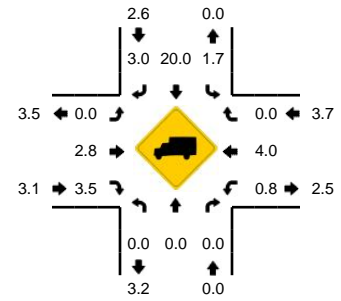

5-Min Count Period Beginning At	I-5 SB Ramp Terminal (Northbound)				I-5 SB Ramp Terminal (Southbound)				SW Nyberg St (Eastbound)				SW Nyberg St (Westbound)				Total	Hourly Totals
	Left	Thru	Right	U	Left	Thru	Right	U	Left	Thru	Right	U	Left	Thru	Right	U		
4:00 PM	0	0	0	0	42	0	66	0	0	104	55	0	15	86	0	0	368	4708
4:05 PM	0	0	0	0	49	0	89	0	0	102	83	0	10	72	0	0	405	4759
4:10 PM	0	0	0	0	34	0	65	0	0	154	67	0	13	107	0	0	440	4797
4:15 PM	0	0	0	0	44	0	93	0	0	116	63	0	8	84	0	0	408	4837
4:20 PM	0	0	0	0	47	0	82	0	0	128	64	0	15	80	0	0	416	4856
4:25 PM	0	0	0	0	33	0	79	0	0	121	54	0	6	111	0	0	404	4851
4:30 PM	0	0	0	0	54	1	105	0	0	103	65	0	12	64	0	0	404	4855
4:35 PM	0	0	0	0	44	0	73	0	0	146	69	0	8	106	0	0	446	4902
4:40 PM	0	0	0	0	68	2	84	0	0	115	76	0	8	76	0	0	429	4917
4:45 PM	0	0	0	0	53	0	78	0	0	112	65	0	19	77	0	0	404	4908
4:50 PM	0	0	0	0	39	0	76	0	0	162	69	0	9	97	0	0	452	4950
4:55 PM	0	0	0	0	58	1	106	0	0	106	61	0	14	72	0	0	418	4994
5:00 PM	0	0	0	0	41	0	69	0	0	131	72	0	12	102	0	0	427	5053
5:05 PM	0	0	0	0	64	1	86	0	0	110	71	0	5	76	0	0	413	5061
5:10 PM	0	0	0	0	36	1	95	0	0	131	71	0	11	83	0	0	428	5049
5:15 PM	0	0	0	0	66	0	96	0	0	106	63	0	12	66	0	0	409	5050
5:20 PM	0	0	0	0	57	0	89	0	0	128	70	0	11	65	0	0	420	5054
5:25 PM	0	0	0	0	47	0	88	0	0	135	64	0	7	90	0	0	431	5081
5:30 PM	0	0	0	0	70	0	114	0	0	100	81	0	4	79	0	0	448	5125
5:35 PM	0	0	0	0	46	0	82	0	0	101	61	0	18	90	0	0	398	5077
5:40 PM	0	0	0	0	64	1	84	0	0	127	66	0	10	101	0	0	453	5101
5:45 PM	0	0	0	0	50	0	111	0	0	109	49	0	14	93	0	0	426	5123
5:50 PM	0	0	0	0	64	0	96	0	0	119	56	0	10	78	0	0	423	5094
5:55 PM	0	0	0	0	43	0	96	0	0	88	45	0	10	72	0	0	354	5030
Peak 15-Min Flowrates	Northbound				Southbound				Eastbound				Westbound				Total	
	Left	Thru	Right	U	Left	Thru	Right	U	Left	Thru	Right	U	Left	Thru	Right	U		
All Vehicles	0	0	0	0	696	0	1164	0	0	1452	860	0	88	936	0	0	5196	
Heavy Trucks	0	0	0	0	24	0	32	0	0	48	44	0	4	28	0	0	180	
Pedestrians	0	0	0	0	0	4	0	0	0	0	0	0	0	0	0	0	4	
Bicycles	0	0	0	0	0	0	0	0	0	0	0	0	0	0	0	0	0	
Railroad	0	0	0	0	0	0	0	0	0	0	0	0	0	0	0	0	0	
Stopped Buses	0	0	0	0	0	0	0	0	0	0	0	0	0	0	0	0	0	

Comments: N

LOCATION: I-5 NB Ramp Terminal -- SW Nyberg St
CITY/STATE: Tualatin, OR

QC JOB #: 10772103
DATE: Tue, Jun 05 2012

Peak-Hour: 4:35 PM -- 5:35 PM
Peak 15-Min: 4:45 PM -- 5:00 PM

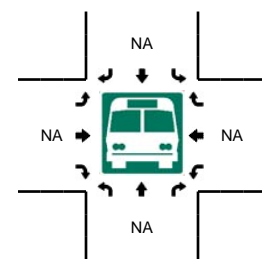
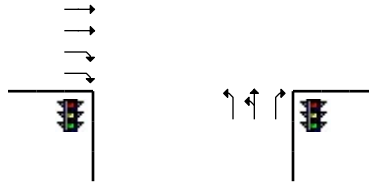
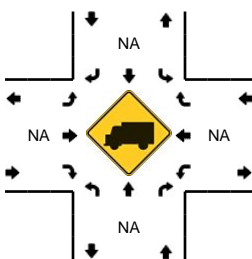
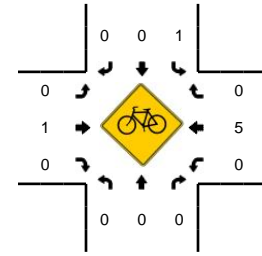
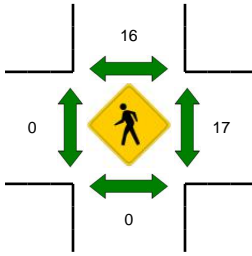
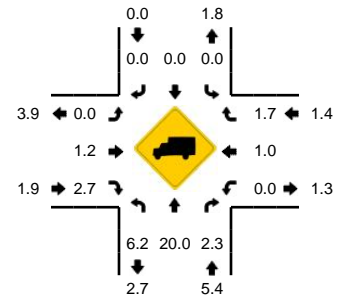
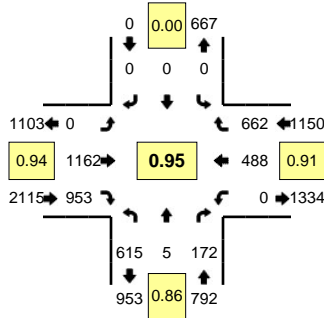

5-Min Count Period Beginning At	I-5 NB Ramp Terminal (Northbound)				I-5 NB Ramp Terminal (Southbound)				SW Nyberg St (Eastbound)				SW Nyberg St (Westbound)				Total	Hourly Totals
	Left	Thru	Right	U	Left	Thru	Right	U	Left	Thru	Right	U	Left	Thru	Right	U		
4:00 PM	35	0	14	0	0	0	0	0	0	85	74	0	0	45	46	0	299	3767
4:05 PM	51	0	9	0	0	0	0	0	0	92	54	0	0	41	48	0	295	3763
4:10 PM	60	0	11	0	0	0	0	0	0	77	102	0	0	57	56	0	363	3795
4:15 PM	44	0	8	0	0	0	0	0	0	69	90	0	0	39	52	0	302	3824
4:20 PM	96	0	12	0	0	0	0	0	0	76	84	0	0	27	46	0	341	3829
4:25 PM	46	1	12	0	0	0	0	0	0	89	85	0	0	39	52	0	324	3818
4:30 PM	61	0	12	0	0	0	0	0	0	84	72	0	0	33	46	0	308	3823
4:35 PM	63	1	10	0	0	0	0	0	0	82	96	0	0	33	46	0	331	3851
4:40 PM	46	0	15	0	0	0	0	0	0	118	67	0	0	49	60	0	355	3852
4:45 PM	67	1	10	0	0	0	0	0	0	80	85	0	0	39	56	0	338	3864
4:50 PM	39	0	21	0	0	0	0	0	0	108	101	0	0	41	65	0	375	3918
4:55 PM	75	1	16	0	0	0	0	0	0	96	77	0	0	30	64	0	359	3990
5:00 PM	43	0	8	0	0	0	0	0	0	92	88	0	0	52	55	0	338	4029
5:05 PM	49	0	20	0	0	0	0	0	0	106	68	0	0	37	62	0	342	4076
5:10 PM	51	0	7	0	0	0	0	0	0	78	91	0	0	50	59	0	336	4049
5:15 PM	30	0	5	0	0	0	0	0	0	104	62	0	0	49	56	0	306	4053
5:20 PM	46	1	16	0	0	0	0	0	0	99	78	0	0	31	58	0	329	4041
5:25 PM	54	1	17	0	0	0	0	0	0	88	79	0	0	41	47	0	327	4044
5:30 PM	52	0	27	0	0	0	0	0	0	111	61	0	0	36	34	0	321	4057
5:35 PM	72	0	25	0	0	0	0	0	0	75	64	0	0	40	44	0	320	4046
5:40 PM	57	0	23	0	0	0	0	0	0	114	83	0	0	49	48	0	374	4065
5:45 PM	70	0	17	0	0	0	0	0	0	92	57	0	0	35	47	0	318	4045
5:50 PM	39	0	10	0	0	0	0	0	0	113	81	0	0	44	52	0	339	4009
5:55 PM	45	0	17	0	0	0	0	0	0	76	53	0	0	35	52	0	278	3928
Peak 15-Min Flowrates	Northbound				Southbound				Eastbound				Westbound				Total	
All Vehicles	724	8	188	0	0	0	0	0	0	1136	1052	0	0	440	740	0	4288	
Heavy Trucks	56	0	4	0	0	0	0	0	0	8	20	0	0	0	20	0	108	
Pedestrians	0	0	0	0	4	0	0	0	0	0	0	0	0	4	0	0	8	
Bicycles	0	0	0	0	0	0	0	0	0	0	0	0	0	1	0	0	1	
Railroad																		
Stopped Buses																		

Comments: N

LOCATION: Signalized Entrance to Nyberg Woods -- SW Nyberg St
CITY/STATE: Tualatin, OR

QC JOB #: 10772101
DATE: Tue, Jun 05 2012

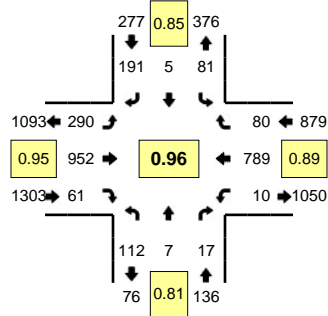

Peak-Hour: 4:35 PM -- 5:35 PM
Peak 15-Min: 5:05 PM -- 5:20 PM

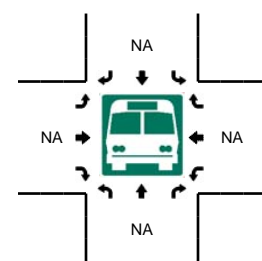
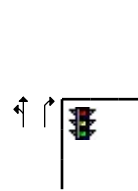
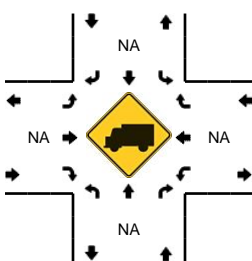
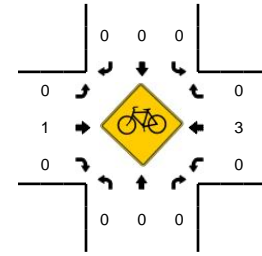
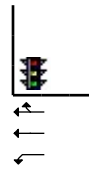
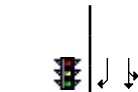
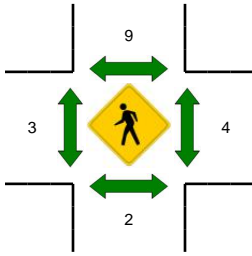
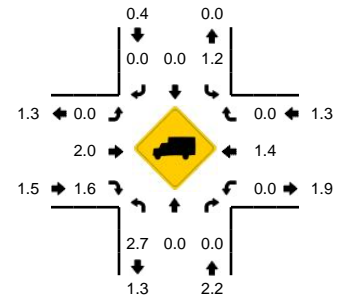

5-Min Count Period Beginning At	Signalized Entrance to Nyberg Woods (Northbound)				Signalized Entrance to Nyberg Woods (Southbound)				SW Nyberg St (Eastbound)				SW Nyberg St (Westbound)				Total	Hourly Totals
	Left	Thru	Right	U	Left	Thru	Right	U	Left	Thru	Right	U	Left	Thru	Right	U		
4:00 PM	5	1	2	0	7	0	16	0	15	76	1	0	2	67	6	0	198	2420
4:05 PM	13	1	2	0	11	0	18	0	20	64	5	0	3	66	4	0	207	2443
4:10 PM	9	1	0	0	9	0	14	0	17	82	6	0	1	73	8	0	220	2454
4:15 PM	3	0	1	0	9	0	19	0	28	38	2	0	1	60	5	1	167	2439
4:20 PM	5	0	1	0	8	1	13	0	21	83	5	0	0	65	2	0	204	2445
4:25 PM	6	0	2	0	4	1	15	0	20	64	4	0	1	52	5	0	174	2382
4:30 PM	7	0	2	0	5	0	15	0	13	67	6	0	0	60	7	0	182	2375
4:35 PM	9	1	0	0	9	0	13	0	22	85	6	0	1	66	5	0	217	2400
4:40 PM	9	1	1	0	4	1	16	0	29	86	6	0	0	78	5	0	236	2415
4:45 PM	13	0	1	0	5	1	13	0	16	70	1	0	0	64	7	0	191	2386
4:50 PM	12	3	0	0	2	1	14	0	32	78	10	0	1	70	6	0	229	2427
4:55 PM	12	0	1	0	7	0	19	0	23	82	4	0	0	61	13	0	222	2447
5:00 PM	8	0	3	0	10	0	17	0	18	69	4	0	1	63	5	0	198	2447
5:05 PM	9	0	4	0	4	1	19	0	28	89	5	0	1	69	6	0	235	2475
5:10 PM	11	1	1	0	5	0	15	0	20	67	4	0	1	80	7	0	212	2467
5:15 PM	8	1	0	0	11	0	21	0	18	85	2	0	1	76	7	0	230	2530
5:20 PM	6	0	2	0	12	1	11	0	24	81	4	0	1	53	3	0	198	2524
5:25 PM	9	0	1	0	6	0	19	0	25	89	7	1	3	59	3	0	222	2572
5:30 PM	6	0	3	0	6	0	14	0	34	71	8	0	0	50	13	0	205	2595
5:35 PM	8	0	0	0	3	2	21	0	25	101	7	0	2	52	7	0	228	2606
5:40 PM	3	1	0	0	10	0	14	0	31	79	9	0	1	68	6	0	222	2592
5:45 PM	4	1	1	0	7	1	17	0	35	88	7	0	0	48	3	0	212	2613
5:50 PM	6	1	2	0	7	1	15	0	26	78	5	0	1	68	6	0	216	2600
5:55 PM	8	0	3	0	17	2	16	0	21	61	4	0	0	59	9	0	200	2578
Peak 15-Min Flowrates	Northbound				Southbound				Eastbound				Westbound				Total	
	Left	Thru	Right	U	Left	Thru	Right	U	Left	Thru	Right	U	Left	Thru	Right	U		
All Vehicles	112	8	20	0	80	4	220	0	264	964	44	0	12	900	80	0	2708	
Heavy Trucks	0	0	0	0	0	0	0	0	0	12	0	0	0	20	0	0	32	
Pedestrians						12				4				0			16	
Bicycles	0	0	0	0	0	0	0	0	0	0	0	0	0	1	0	0	1	
Railroad																		
Stopped Buses																		

Comments: N

LOCATION: SW Martinazzi Ave -- SW Boones Ferry Rd
CITY/STATE: Tualatin, OR

QC JOB #: 10772126
DATE: Sat, Jun 09 2012

Peak-Hour: 12:10 PM -- 1:10 PM
Peak 15-Min: 12:50 PM -- 1:05 PM

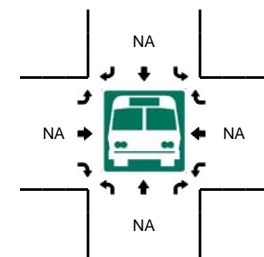
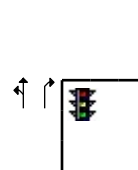
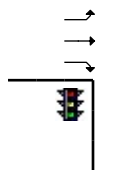
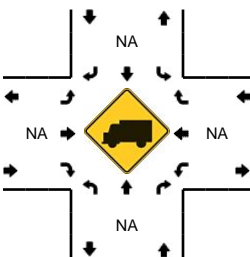
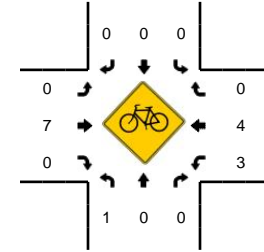
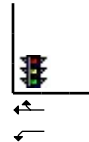
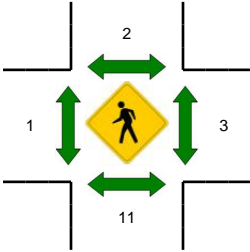
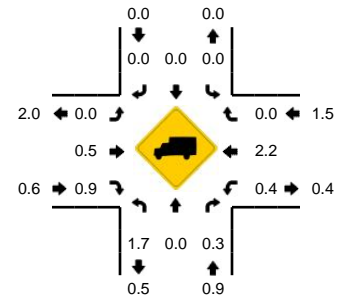
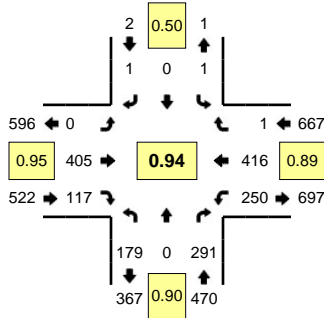

5-Min Count Period Beginning At	SW Martinazzi Ave (Northbound)				SW Martinazzi Ave (Southbound)				SW Boones Ferry Rd (Eastbound)				SW Boones Ferry Rd (Westbound)				Total	Hourly Totals
	Left	Thru	Right	U	Left	Thru	Right	U	Left	Thru	Right	U	Left	Thru	Right	U		
11:40 AM	16	0	17	0	0	0	0	0	0	41	5	0	31	38	0	0	148	
11:45 AM	13	1	20	0	0	0	0	0	0	40	8	0	21	40	0	0	143	
11:50 AM	18	0	30	0	0	0	0	0	0	39	10	0	26	39	0	0	162	
11:55 AM	20	0	17	0	0	0	0	0	0	29	9	0	15	37	0	0	127	1525
12:00 PM	15	0	20	0	0	0	0	0	0	39	9	0	21	35	0	0	139	1560
12:05 PM	7	1	17	0	0	0	0	0	0	36	7	0	17	49	0	0	134	1576
12:10 PM	8	0	34	0	1	0	0	0	0	32	14	0	22	26	1	0	138	1603
12:15 PM	14	0	23	0	0	0	0	0	0	44	4	0	20	36	0	0	141	1631
12:20 PM	12	0	23	0	0	0	0	0	0	37	6	0	20	35	0	0	133	1635
12:25 PM	16	0	25	0	0	0	0	0	0	27	17	0	33	34	0	0	152	1663
12:30 PM	21	0	24	0	0	0	1	0	0	30	9	0	20	32	0	0	137	1690
12:35 PM	15	0	30	0	0	0	0	0	0	31	8	0	14	30	0	0	128	1682
12:40 PM	7	0	17	0	0	0	0	0	0	33	8	0	16	33	0	0	114	1648
12:45 PM	19	0	27	0	0	0	0	0	0	36	9	0	17	44	0	0	152	1657
12:50 PM	16	0	24	0	0	0	0	0	0	31	10	0	21	40	0	0	142	1637
12:55 PM	20	0	22	0	0	0	0	0	0	31	7	0	29	33	0	0	142	1652
1:00 PM	22	0	22	0	0	0	0	0	0	37	13	0	22	42	0	0	158	1671
1:05 PM	9	0	20	0	0	0	0	0	0	36	12	0	16	31	0	0	124	1661
1:10 PM	9	0	17	0	0	0	0	0	0	38	4	0	18	38	0	0	124	1647
1:15 PM	11	0	18	0	0	0	0	0	0	36	4	0	25	38	0	0	132	1638
1:20 PM	18	0	20	0	0	0	0	0	0	25	3	0	24	39	0	0	129	1634
1:25 PM	13	0	28	0	0	0	0	0	0	35	5	0	18	36	0	0	135	1617
1:30 PM	19	0	19	0	0	0	0	0	0	33	9	0	18	40	0	0	138	1618
1:35 PM	14	0	24	0	0	0	0	0	0	36	6	0	26	40	0	0	146	1636
Peak 15-Min Flowrates	Northbound				Southbound				Eastbound				Westbound				Total	
	Left	Thru	Right	U	Left	Thru	Right	U	Left	Thru	Right	U	Left	Thru	Right	U		
All Vehicles	232	0	272	0	0	0	0	0	0	396	120	0	288	460	0	0	1768	
Heavy Trucks	8	0	4	0	0	0	0	0	0	0	0	0	0	12	0	0	24	
Pedestrians			12				0				0			4			16	
Bicycles	1	0	0		0	0	0		0	0	0		0	1	0		2	
Railroad																		
Stopped Buses																		

Comments: N

LOCATION: SW Martinazzi Ave -- Existing Site Dwy near City Hall
CITY/STATE: Tualatin, OR

QC JOB #: 10772124
DATE: Sat, Jun 09 2012

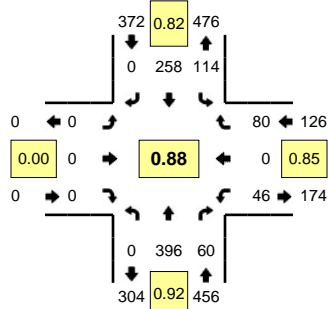

Peak-Hour: 12:10 PM -- 1:10 PM
Peak 15-Min: 12:20 PM -- 12:35 PM

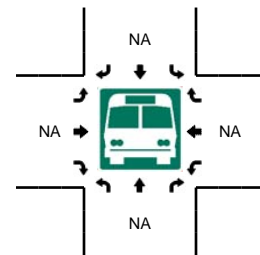
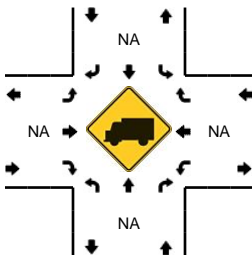
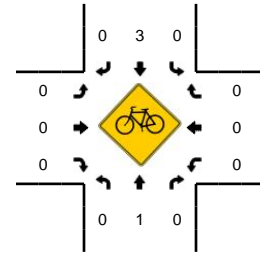
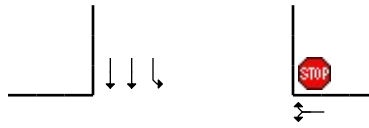
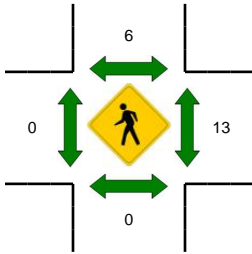
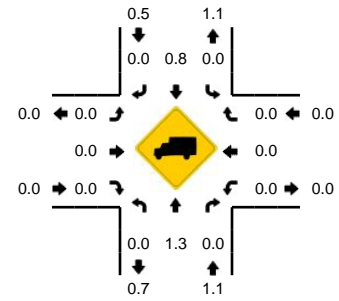

5-Min Count Period Beginning At	SW Martinazzi Ave (Northbound)				SW Martinazzi Ave (Southbound)				Existing Site Dwy near City Hall (Eastbound)				Existing Site Dwy near City Hall (Westbound)				Total	Hourly Totals
	Left	Thru	Right	U	Left	Thru	Right	U	Left	Thru	Right	U	Left	Thru	Right	U		
11:40 AM	0	31	10	0	11	22	0	0	0	0	0	0	2	0	5	0	81	
11:45 AM	0	32	7	0	8	21	0	0	0	0	0	0	2	0	5	0	75	
11:50 AM	0	31	5	0	13	23	0	0	0	0	0	0	4	0	8	0	84	
11:55 AM	0	32	4	0	7	17	0	0	0	0	0	0	2	0	7	0	69	831
12:00 PM	0	33	3	0	9	19	0	0	0	0	0	0	4	0	3	0	71	845
12:05 PM	0	23	4	0	7	22	0	0	0	0	0	0	2	0	4	0	62	843
12:10 PM	0	30	4	0	9	26	0	0	0	0	0	0	3	0	10	0	82	864
12:15 PM	0	35	9	0	8	14	0	0	0	0	0	0	3	0	6	0	75	877
12:20 PM	0	28	6	0	15	18	0	0	0	0	0	0	5	0	6	0	78	885
12:25 PM	0	38	6	0	17	28	0	0	0	0	0	0	4	0	11	0	104	913
12:30 PM	0	39	3	0	14	21	0	0	0	0	0	0	5	0	6	0	88	939
12:35 PM	0	34	4	0	6	17	0	0	0	0	0	0	4	0	6	0	71	940
12:40 PM	0	21	9	0	2	20	0	0	0	0	0	0	3	0	5	0	60	919
12:45 PM	0	38	2	0	7	18	0	0	0	0	0	0	6	0	6	0	77	921
12:50 PM	0	37	5	0	13	18	0	0	0	0	0	0	3	0	5	0	81	918
12:55 PM	0	32	5	0	8	28	0	0	0	0	0	0	3	0	9	0	85	934
1:00 PM	0	37	2	0	5	31	0	0	0	0	0	0	4	0	6	0	85	948
1:05 PM	0	27	5	0	10	19	0	0	0	0	0	0	3	0	4	0	68	954
1:10 PM	0	21	3	0	3	19	0	0	0	0	0	0	3	0	7	0	56	928
1:15 PM	0	25	5	0	7	25	0	0	0	0	0	0	1	0	6	0	69	922
1:20 PM	0	31	6	0	4	21	0	0	0	0	0	0	3	0	3	0	68	912
1:25 PM	0	34	5	0	7	16	0	0	0	0	0	0	4	0	9	0	75	883
1:30 PM	0	31	6	0	6	20	0	0	0	0	0	0	3	0	4	0	70	865
1:35 PM	0	33	5	0	11	22	0	0	0	0	0	0	4	0	7	0	82	876
Peak 15-Min Flowrates	Northbound				Southbound				Eastbound				Westbound				Total	
All Vehicles	0	420	60	0	184	268	0	0	0	0	0	0	56	0	92	0	1080	
Heavy Trucks	0	4	0	0	0	4	0	0	0	0	0	0	0	0	0	0	8	
Pedestrians	0	0	0	0	0	0	0	0	0	0	0	0	8	0	0	0	8	
Bicycles	0	0	0	0	0	0	0	0	0	0	0	0	0	0	0	0	0	
Railroad																		
Stopped Buses																		

Comments: N

LOCATION: SW Martinazzi Ave -- SW Seneca St
CITY/STATE: Tualatin, OR

QC JOB #: 10772122
DATE: Sat, Jun 09 2012

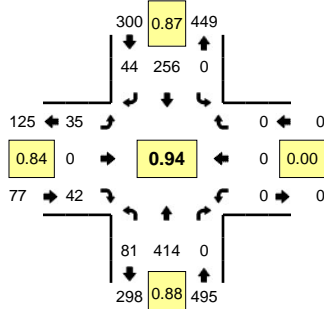

Peak-Hour: 12:10 PM -- 1:10 PM
Peak 15-Min: 12:45 PM -- 1:00 PM

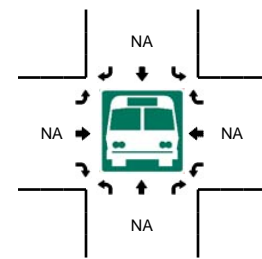
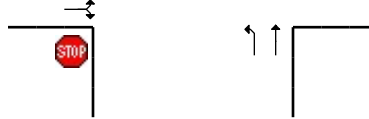
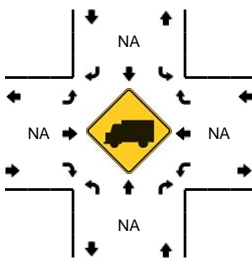
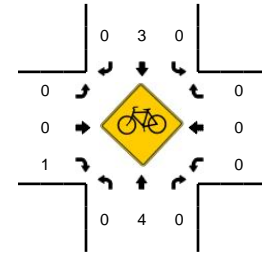
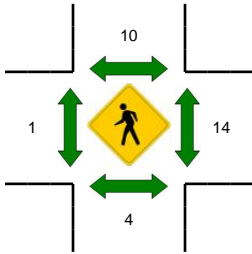
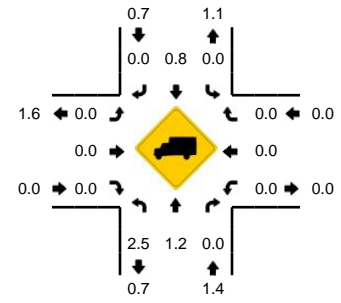

5-Min Count Period Beginning At	SW Martinazzi Ave (Northbound)				SW Martinazzi Ave (Southbound)				SW Seneca St (Eastbound)				SW Seneca St (Westbound)				Total	Hourly Totals
	Left	Thru	Right	U	Left	Thru	Right	U	Left	Thru	Right	U	Left	Thru	Right	U		
11:40 AM	4	35	0	0	0	28	0	0	2	0	3	0	0	0	0	0	72	
11:45 AM	4	41	0	0	0	24	1	0	3	0	2	0	0	0	0	0	75	
11:50 AM	5	36	0	0	0	18	1	0	3	0	3	0	0	0	0	0	66	
11:55 AM	10	28	0	0	0	15	2	0	2	0	0	0	0	0	0	0	57	764
12:00 PM	5	32	0	0	0	23	5	0	3	0	7	0	0	0	0	0	75	776
12:05 PM	8	26	0	0	0	24	2	0	0	0	2	0	0	0	0	0	62	778
12:10 PM	10	35	0	0	0	22	2	0	4	0	6	0	0	0	0	0	79	801
12:15 PM	3	42	0	0	0	17	3	0	1	0	6	0	0	0	0	0	72	808
12:20 PM	5	29	0	0	0	19	3	0	4	0	2	0	0	0	0	0	62	816
12:25 PM	5	43	0	0	0	26	4	0	3	0	1	0	0	0	0	0	82	829
12:30 PM	8	33	0	0	0	21	3	0	3	0	5	0	0	0	0	0	73	845
12:35 PM	4	32	0	0	0	14	5	0	5	0	2	0	0	0	0	0	62	837
12:40 PM	3	25	0	0	0	22	5	0	4	0	1	0	0	0	0	0	60	825
12:45 PM	9	42	0	0	0	24	3	0	3	0	1	0	0	0	0	0	82	832
12:50 PM	6	41	0	0	0	21	0	0	1	0	5	0	0	0	0	0	74	840
12:55 PM	10	33	0	0	0	25	7	0	0	0	2	0	0	0	0	0	77	860
1:00 PM	8	33	0	0	0	23	4	0	1	0	7	0	0	0	0	0	76	861
1:05 PM	10	26	0	0	0	22	5	0	6	0	4	0	0	0	0	0	73	872
1:10 PM	5	28	0	0	0	15	3	0	2	0	4	0	0	0	0	0	57	850
1:15 PM	6	29	0	0	0	22	4	0	5	0	8	0	0	0	0	0	74	852
1:20 PM	8	33	0	0	0	21	3	0	3	0	5	0	0	0	0	0	73	863
1:25 PM	5	40	0	0	0	14	6	0	3	0	6	0	0	0	0	0	74	855
1:30 PM	7	26	0	0	0	19	4	0	1	0	6	0	0	0	0	0	63	845
1:35 PM	6	37	0	0	0	21	6	0	3	0	3	0	0	0	0	0	76	859
Peak 15-Min Flowrates	Northbound				Southbound				Eastbound				Westbound				Total	
All Vehicles	100	464	0	0	0	280	40	0	16	0	32	0	0	0	0	0	932	
Heavy Trucks	4	16	0	0	0	0	0	0	0	0	0	0	0	0	0	0	20	
Pedestrians		8				12				4				28			52	
Bicycles	0	2	0	0	0	1	0	0	0	0	0	0	0	0	0	0	3	
Railroad																		
Stopped Buses																		

Comments: N

LOCATION: SW Martinazzi Ave -- Existing Site Dwy
CITY/STATE: Tualatin, OR

QC JOB #: 10772120
DATE: Sat, Jun 09 2012

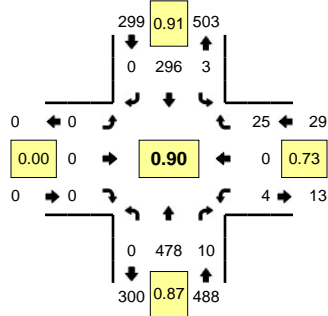

Peak-Hour: 12:10 PM -- 1:10 PM
Peak 15-Min: 12:45 PM -- 1:00 PM

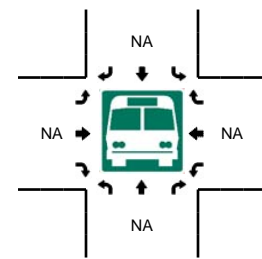
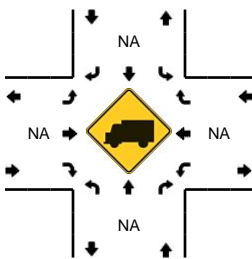
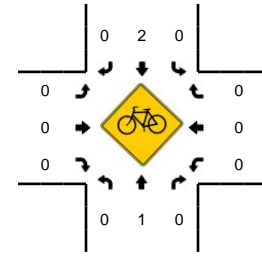
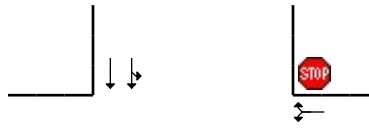
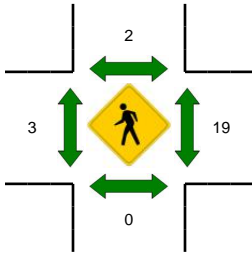
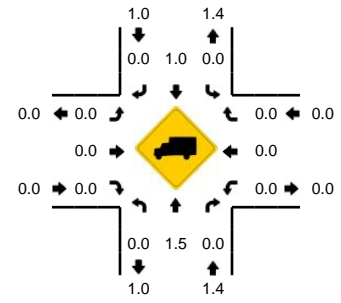

5-Min Count Period Beginning At	SW Martinazzi Ave (Northbound)				SW Martinazzi Ave (Southbound)				Existing Site Dwy (Eastbound)				Existing Site Dwy (Westbound)				Total	Hourly Totals	
	Left	Thru	Right	U	Left	Thru	Right	U	Left	Thru	Right	U	Left	Thru	Right	U			
11:40 AM	0	39	1	0	0	31	0	0	0	0	0	0	0	0	0	1	0	72	
11:45 AM	0	44	0	0	0	26	0	0	0	0	0	0	0	0	0	1	0	71	
11:50 AM	0	35	0	0	0	23	0	0	0	0	0	0	0	0	5	0	63		
11:55 AM	0	37	2	0	0	16	0	0	0	0	0	0	0	0	2	0	57	725	
12:00 PM	0	35	1	0	0	29	0	0	0	0	0	0	0	1	0	3	0	69	738
12:05 PM	0	34	0	0	0	24	0	0	0	0	0	0	0	0	0	0	0	58	736
12:10 PM	0	41	1	0	0	28	0	0	0	0	0	0	0	0	0	2	0	72	761
12:15 PM	0	49	2	0	1	22	0	0	0	0	0	0	0	0	0	0	0	74	772
12:20 PM	0	33	1	0	1	21	0	0	0	0	0	0	0	1	0	1	0	58	781
12:25 PM	0	43	0	0	0	28	0	0	0	0	0	0	0	0	0	3	0	74	789
12:30 PM	0	37	1	0	0	25	0	0	0	0	0	0	0	0	0	4	0	67	800
12:35 PM	0	33	2	0	0	16	0	0	0	0	0	0	0	1	0	2	0	54	789
12:40 PM	0	31	0	0	0	24	0	0	0	0	0	0	0	0	0	1	0	56	773
12:45 PM	0	50	0	0	0	25	0	0	0	0	0	0	0	0	0	2	0	77	779
12:50 PM	0	45	1	0	1	25	0	0	0	0	0	0	0	0	0	4	0	76	792
12:55 PM	0	42	2	0	0	27	0	0	0	0	0	0	0	0	0	2	0	73	808
1:00 PM	0	37	0	0	0	29	0	0	0	0	0	0	0	1	0	2	0	69	808
1:05 PM	0	37	0	0	0	26	0	0	0	0	0	0	0	1	0	2	0	66	816
1:10 PM	0	26	0	0	0	19	0	0	0	0	0	0	0	0	0	2	0	47	791
1:15 PM	0	34	0	0	0	32	0	0	0	0	0	0	0	0	0	0	0	66	783
1:20 PM	0	43	1	0	0	26	0	0	0	0	0	0	0	1	0	0	0	71	796
1:25 PM	0	41	0	0	1	18	0	0	0	0	0	0	0	0	0	3	0	63	785
1:30 PM	0	33	0	0	0	25	0	0	0	0	0	0	0	1	0	1	0	60	778
1:35 PM	0	41	0	0	0	24	0	0	0	0	0	0	0	1	0	0	0	66	790
Peak 15-Min Flowrates	Northbound				Southbound				Eastbound				Westbound				Total		
All Vehicles	0	548	12	0	4	308	0	0	0	0	0	0	0	0	32	0	904		
Heavy Trucks	0	20	0		0	0	0		0	0	0		0	0	0		20		
Pedestrians		0			4				12				36				52		
Bicycles	0	1	0		0	1	0		0	0	0		0	0	0		2		
Railroad																			
Stopped Buses																			

Comments: N

LOCATION: SW Martinazzi Ave -- Existing Right-Out Only Dwy
CITY/STATE: Tualatin, OR

QC JOB #: 10772118
DATE: Sat, Jun 09 2012

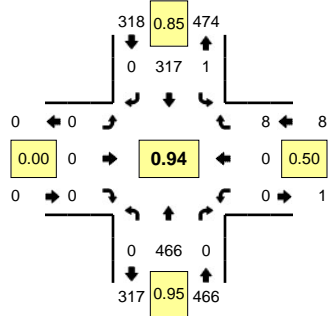

Peak-Hour: 12:10 PM -- 1:10 PM
Peak 15-Min: 12:50 PM -- 1:05 PM

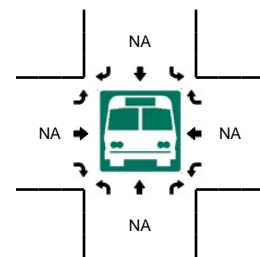
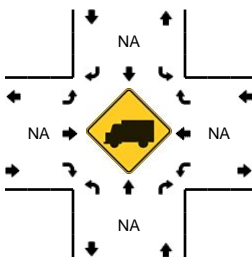
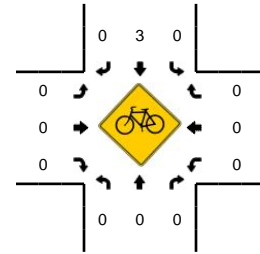
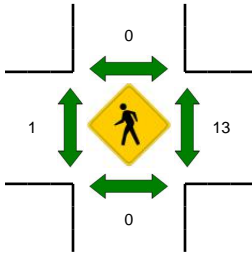
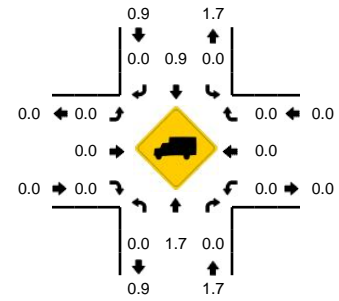

5-Min Count Period Beginning At	SW Martinazzi Ave (Northbound)				SW Martinazzi Ave (Southbound)				Existing Right-Out Only Dwy (Eastbound)				Existing Right-Out Only Dwy (Westbound)				Total	Hourly Totals
	Left	Thru	Right	U	Left	Thru	Right	U	Left	Thru	Right	U	Left	Thru	Right	U		
11:40 AM	0	35	0	0	0	30	0	0	0	0	0	0	0	0	0	0	65	
11:45 AM	0	42	0	0	0	25	0	0	0	0	0	0	0	0	1	0	68	
11:50 AM	0	35	0	0	0	23	0	0	0	0	0	0	0	0	0	0	58	
11:55 AM	0	37	0	0	0	17	0	0	0	0	0	0	0	0	2	0	56	707
12:00 PM	0	37	0	0	0	32	0	0	0	0	0	0	0	0	1	0	70	716
12:05 PM	0	31	0	0	0	27	0	0	0	0	0	0	0	0	0	0	58	717
12:10 PM	0	41	0	0	0	29	0	0	0	0	0	0	0	0	4	0	74	737
12:15 PM	0	44	0	0	0	21	0	0	0	0	0	0	0	0	0	0	65	744
12:20 PM	0	34	0	0	0	22	0	0	0	0	0	0	0	0	0	0	56	748
12:25 PM	0	43	0	0	0	28	0	0	0	0	0	0	0	0	0	0	71	761
12:30 PM	0	43	0	0	0	25	0	0	0	0	0	0	0	0	0	0	68	774
12:35 PM	0	29	0	0	0	18	0	0	0	0	0	0	0	0	0	0	47	756
12:40 PM	0	33	0	0	0	28	0	0	0	0	0	0	0	0	1	0	62	753
12:45 PM	0	43	0	0	0	27	0	0	0	0	0	0	0	0	1	0	71	756
12:50 PM	0	45	0	0	0	26	0	0	0	0	0	0	0	0	1	0	72	770
12:55 PM	0	33	0	0	0	24	0	0	0	0	0	0	0	0	0	0	57	771
1:00 PM	0	44	0	0	1	37	0	0	0	0	0	0	0	0	0	0	82	783
1:05 PM	0	34	0	0	0	32	0	0	0	0	0	0	0	0	1	0	67	792
1:10 PM	0	23	0	0	0	25	0	0	0	0	0	0	0	0	1	0	49	767
1:15 PM	0	33	0	0	0	31	0	0	0	0	0	0	0	0	1	0	65	767
1:20 PM	0	45	0	0	0	34	0	0	0	0	0	0	0	0	1	0	80	791
1:25 PM	0	37	0	0	0	20	0	0	0	0	0	0	0	0	3	0	60	780
1:30 PM	0	31	0	0	0	27	0	0	0	0	0	0	0	0	1	0	59	771
1:35 PM	0	43	0	0	0	27	0	0	0	0	0	0	0	0	3	0	73	797
Peak 15-Min Flowrates	Northbound				Southbound				Eastbound				Westbound				Total	
All Vehicles	0	488	0	0	4	348	0	0	0	0	0	0	0	0	4	0	844	
Heavy Trucks	0	16	0	0	0	0	0	0	0	0	0	0	0	0	0	0	16	
Pedestrians	0	0	0	0	0	0	0	0	4	0	0	0	24	0	0	0	28	
Bicycles	0	0	0	0	0	0	0	0	0	0	0	0	0	0	0	0	0	
Railroad																		
Stopped Buses																		

Comments: N

LOCATION: SW Martinazzi Ave -- SW Tualatin-Sherwood Rd
CITY/STATE: Tualatin, OR

QC JOB #: 10772116
DATE: Sat, Jun 09 2012

Peak-Hour: 12:10 PM -- 1:10 PM
Peak 15-Min: 12:25 PM -- 12:40 PM

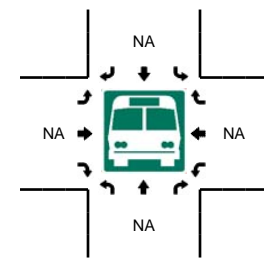
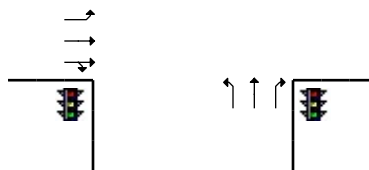
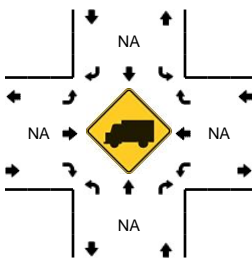
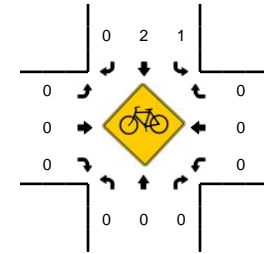
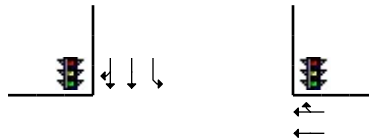
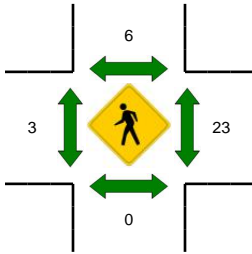
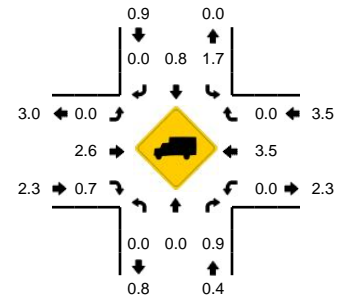
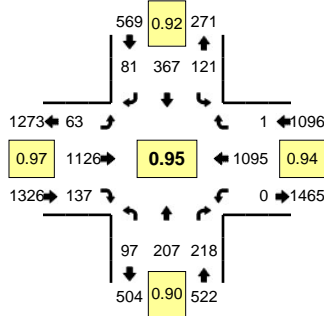

5-Min Count Period Beginning At	SW Martinazzi Ave (Northbound)				SW Martinazzi Ave (Southbound)				SW Tualatin-Sherwood Rd (Eastbound)				SW Tualatin-Sherwood Rd (Westbound)				Total	Hourly Totals
	Left	Thru	Right	U	Left	Thru	Right	U	Left	Thru	Right	U	Left	Thru	Right	U		
11:40 AM	8	25	16	0	11	29	9	0	6	84	10	0	0	82	0	0	280	
11:45 AM	6	14	27	0	10	38	6	0	7	83	9	0	0	100	0	0	300	
11:50 AM	12	20	20	0	9	26	9	0	5	111	21	0	0	80	0	0	313	
11:55 AM	6	14	23	0	8	24	8	0	6	87	7	0	0	104	0	0	287	3388
12:00 PM	14	10	19	0	10	30	9	0	1	97	14	0	0	85	1	0	290	3416
12:05 PM	3	17	23	0	8	35	9	0	1	88	7	0	0	86	0	0	277	3411
12:10 PM	10	15	16	0	15	25	3	0	4	98	14	0	0	74	0	0	274	3429
12:15 PM	10	16	12	0	9	46	5	0	6	93	10	0	0	106	0	0	313	3450
12:20 PM	5	19	15	0	2	29	12	0	5	80	6	0	0	95	1	0	269	3452
12:25 PM	10	13	19	0	5	35	9	0	7	114	17	0	0	90	0	0	319	3511
12:30 PM	11	24	21	0	17	39	2	0	7	81	15	0	0	96	0	0	313	3547
12:35 PM	8	18	21	0	14	29	4	0	6	87	8	0	0	97	0	0	292	3527
12:40 PM	7	14	16	0	5	29	10	0	3	113	11	0	0	89	0	0	297	3544
12:45 PM	4	27	20	0	10	36	7	0	5	81	14	0	0	74	0	0	278	3522
12:50 PM	11	10	18	0	12	20	5	0	7	95	13	0	0	98	0	0	289	3498
12:55 PM	8	15	17	0	7	36	4	0	7	95	3	0	0	97	0	0	289	3500
1:00 PM	5	16	24	0	12	26	14	0	3	75	15	0	0	88	0	0	278	3488
1:05 PM	8	20	19	0	13	17	6	0	3	114	11	0	0	91	0	0	302	3513
1:10 PM	15	15	22	0	16	37	5	0	4	91	10	0	0	73	0	0	288	3527
1:15 PM	10	13	12	0	11	39	4	0	5	74	7	0	0	75	0	0	250	3464
1:20 PM	7	17	22	0	14	36	8	0	9	115	10	0	0	107	0	0	345	3540
1:25 PM	7	11	16	0	11	30	4	0	6	102	16	0	0	108	0	0	311	3532
1:30 PM	11	20	25	0	9	44	6	0	6	88	9	0	0	72	0	0	290	3509
1:35 PM	14	17	19	0	9	25	5	0	4	108	8	0	0	104	0	0	313	3530
Peak 15-Min Flowrates	Northbound				Southbound				Eastbound				Westbound				Total	
All Vehicles	116	220	244	0	144	412	60	0	80	1128	160	0	0	1132	0	0	3696	
Heavy Trucks	0	0	4		4	4	0		0	44	0		0	24	0		80	
Pedestrians						8				8				4			20	
Bicycles	0	0	0		0	0	0		0	0	0		0	0	0		0	
Railroad																		
Stopped Buses																		

Comments: N

LOCATION: SW Martinazzi Ave -- SW Nyberg St
CITY/STATE: Tualatin, OR

QC JOB #: 10772114
DATE: Sat, Jun 09 2012

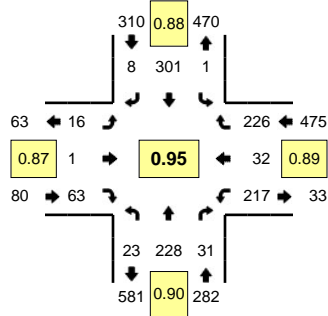

Peak-Hour: 12:10 PM -- 1:10 PM
Peak 15-Min: 12:20 PM -- 12:35 PM

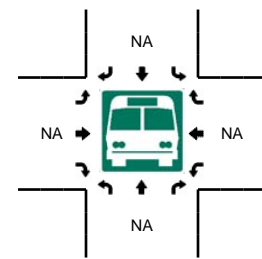
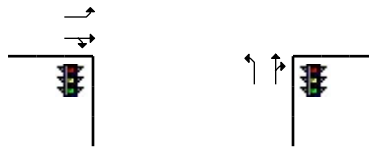
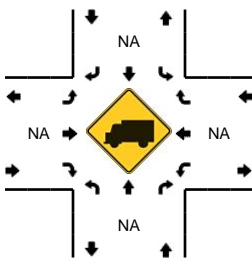
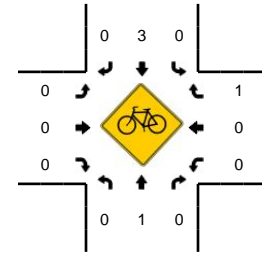
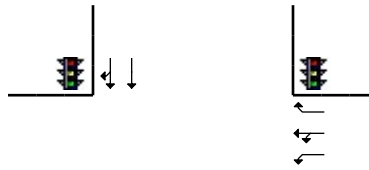
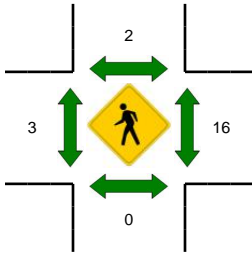
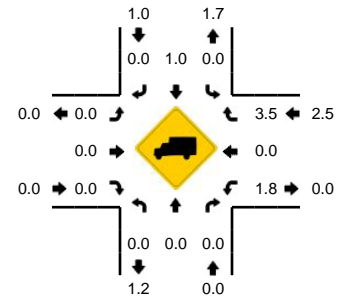

5-Min Count Period Beginning At	SW Martinazzi Ave (Northbound)				SW Martinazzi Ave (Southbound)				SW Nyberg St (Eastbound)				SW Nyberg St (Westbound)				Total	Hourly Totals
	Left	Thru	Right	U	Left	Thru	Right	U	Left	Thru	Right	U	Left	Thru	Right	U		
11:40 AM	1	17	2	0	0	30	1	0	1	0	4	0	15	3	20	0	94	
11:45 AM	2	16	5	0	0	27	0	0	1	0	5	0	25	4	22	0	107	
11:50 AM	5	17	1	0	0	23	0	0	1	0	4	0	15	5	17	0	88	
11:55 AM	2	15	2	0	0	19	0	0	1	0	7	0	15	3	23	0	87	1043
12:00 PM	0	16	1	0	0	28	0	0	1	0	3	0	19	4	22	0	94	1052
12:05 PM	0	15	0	0	0	32	0	0	1	0	7	0	16	4	16	0	91	1059
12:10 PM	0	17	4	0	0	27	1	0	1	0	2	0	22	6	25	0	105	1086
12:15 PM	4	26	1	0	1	22	2	0	3	0	6	0	11	2	11	0	89	1087
12:20 PM	1	13	1	0	0	22	0	0	0	0	8	0	22	4	21	0	92	1107
12:25 PM	2	21	4	0	0	25	1	0	3	0	2	0	21	1	18	0	98	1123
12:30 PM	2	27	1	0	0	29	0	0	2	0	5	0	26	4	17	0	113	1151
12:35 PM	1	17	1	0	0	16	0	0	1	0	9	0	22	1	12	0	80	1138
12:40 PM	5	14	3	0	0	24	2	0	1	0	5	0	27	0	18	0	99	1143
12:45 PM	2	21	7	0	0	26	0	0	0	1	6	0	14	4	22	0	103	1139
12:50 PM	1	24	1	0	0	24	0	0	1	0	6	0	11	1	21	0	90	1141
12:55 PM	3	16	1	0	0	30	1	0	3	0	3	0	14	1	26	0	98	1152
1:00 PM	0	9	2	0	0	29	0	0	1	0	6	0	9	3	22	0	81	1139
1:05 PM	2	23	5	0	0	27	1	0	0	0	5	0	18	5	13	0	99	1147
1:10 PM	2	12	1	0	0	22	0	0	1	0	9	0	23	1	11	0	82	1124
1:15 PM	1	18	1	0	0	31	0	0	1	0	3	0	25	1	15	0	96	1131
1:20 PM	1	22	0	0	0	32	0	0	2	0	5	0	16	6	18	0	102	1141
1:25 PM	0	24	4	0	0	18	0	0	1	0	6	0	27	5	12	0	97	1140
1:30 PM	0	12	4	0	0	24	2	0	1	1	7	0	16	2	18	0	87	1114
1:35 PM	1	24	2	0	0	28	2	0	2	1	4	0	16	2	18	0	100	1134
Peak 15-Min Flowrates	Northbound				Southbound				Eastbound				Westbound				Total	
All Vehicles	20	244	24	0	0	304	4	0	20	0	60	0	276	36	224	0	1212	
Heavy Trucks	0	0	0	0	0	4	0	0	0	0	0	0	8	0	8	0	20	
Pedestrians	0	0	0	0	0	0	0	0	0	4	0	0	0	0	0	0	4	
Bicycles	0	0	0	0	0	0	0	0	0	0	0	0	0	0	0	0	0	
Railroad																		
Stopped Buses																		

Comments: N

LOCATION: Unsignalized Site Dwy -- SW Nyberg St
CITY/STATE: Tualatin, OR

QC JOB #: 10772112
DATE: Sat, Jun 09 2012

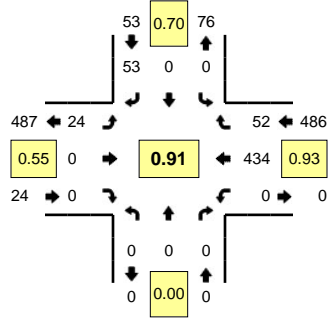

Peak-Hour: 12:10 PM -- 1:10 PM
Peak 15-Min: 12:20 PM -- 12:35 PM

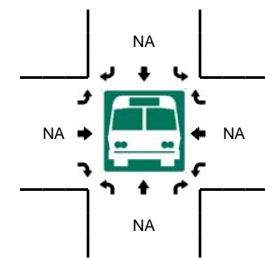
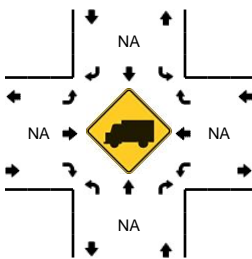
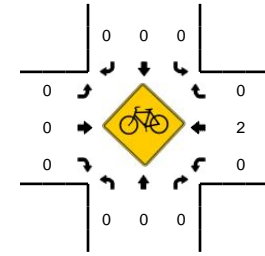
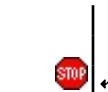
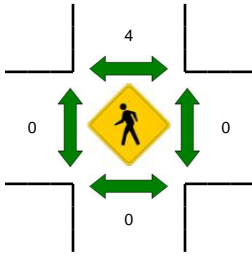
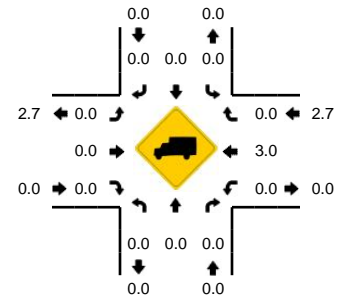

5-Min Count Period Beginning At	Unsignalized Site Dwy (Northbound)				Unsignalized Site Dwy (Southbound)				SW Nyberg St (Eastbound)				SW Nyberg St (Westbound)				Total	Hourly Totals
	Left	Thru	Right	U	Left	Thru	Right	U	Left	Thru	Right	U	Left	Thru	Right	U		
11:40 AM	0	0	0	0	0	0	2	0	2	0	0	0	0	34	2	0	40	
11:45 AM	0	0	0	0	0	0	10	0	2	0	0	0	0	37	5	0	54	
11:50 AM	0	0	0	0	0	0	3	0	3	0	0	0	0	31	4	0	41	
11:55 AM	0	0	0	0	0	0	0	0	1	0	0	0	0	40	1	0	42	481
12:00 PM	0	0	0	0	0	0	6	0	1	0	0	0	0	39	3	0	49	497
12:05 PM	0	0	0	0	0	0	5	0	1	0	0	0	0	27	2	0	35	488
12:10 PM	0	0	0	0	0	0	3	0	2	0	0	0	0	48	4	0	57	508
12:15 PM	0	0	0	0	0	0	0	0	2	0	0	0	0	35	4	0	41	515
12:20 PM	0	0	0	0	0	0	8	0	1	0	0	0	0	33	5	0	47	527
12:25 PM	0	0	0	0	0	0	9	0	2	0	0	0	0	38	6	0	55	540
12:30 PM	0	0	0	0	0	0	2	0	2	0	0	0	0	43	5	0	52	557
12:35 PM	0	0	0	0	0	0	8	0	1	0	0	0	0	28	4	0	41	554
12:40 PM	0	0	0	0	0	0	7	0	2	0	0	0	0	34	4	0	47	561
12:45 PM	0	0	0	0	0	0	4	0	5	0	0	0	0	34	3	0	46	553
12:50 PM	0	0	0	0	0	0	4	0	3	0	0	0	0	35	4	0	46	558
12:55 PM	0	0	0	0	0	0	4	0	3	0	0	0	0	35	4	0	46	562
1:00 PM	0	0	0	0	0	0	2	0	1	0	0	0	0	42	4	0	49	562
1:05 PM	0	0	0	0	0	0	2	0	0	0	0	0	0	29	5	0	36	563
1:10 PM	0	0	0	0	0	0	4	0	0	0	0	0	0	29	6	0	39	545
1:15 PM	0	0	0	0	0	0	5	0	1	0	0	0	0	31	5	0	42	546
1:20 PM	0	0	0	0	0	0	7	0	1	0	0	0	0	32	4	0	44	543
1:25 PM	0	0	0	0	0	0	7	0	2	0	0	0	0	40	9	0	58	546
1:30 PM	0	0	0	0	0	0	4	0	5	0	0	0	0	39	2	0	50	544
1:35 PM	0	0	0	0	0	0	3	0	4	0	0	0	0	31	5	0	43	546
Peak 15-Min Flowrates	Northbound				Southbound				Eastbound				Westbound				Total	
	Left	Thru	Right	U	Left	Thru	Right	U	Left	Thru	Right	U	Left	Thru	Right	U		
All Vehicles	0	0	0	0	0	0	76	0	20	0	0	0	0	456	64	0	616	
Heavy Trucks	0	0	0	0	0	0	0	0	0	0	0	0	0	16	0	0	16	
Pedestrians					4				0				0				4	
Bicycles	0	0	0	0	0	0	0	0	0	0	0	0	0	0	0	0	0	
Railroad																		
Stopped Buses																		

Comments: N

LOCATION: Fred Meyer/Site Dwy -- SW Nyberg St/SW Tualatin-Sherwood Rd
CITY/STATE: Tualatin, OR

QC JOB #: 10772110
DATE: Sat, Jun 09 2012

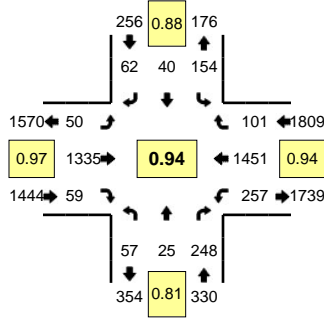

Peak-Hour: 12:10 PM -- 1:10 PM
Peak 15-Min: 12:25 PM -- 12:40 PM

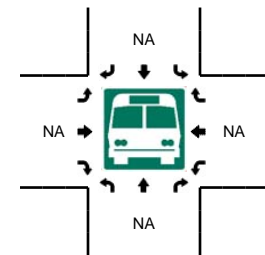
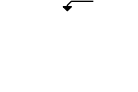
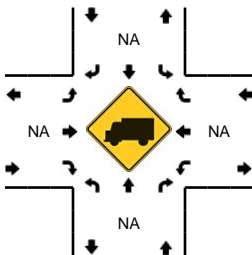
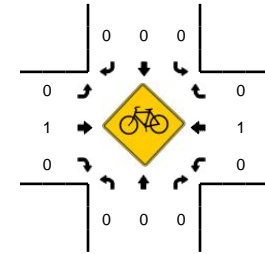
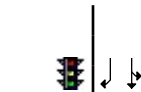
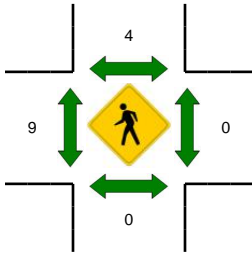
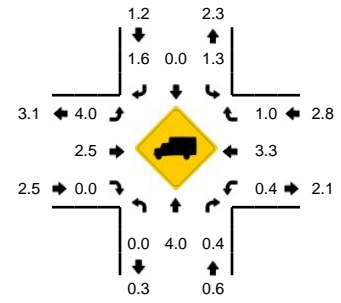

5-Min Count Period Beginning At	Fred Meyer/Site Dwy (Northbound)				Fred Meyer/Site Dwy (Southbound)				SW Nyberg St/SW Tualatin-Sherwood Rd (Eastbound)				SW Nyberg St/SW Tualatin-Sherwood Rd (Westbound)				Total	Hourly Totals
	Left	Thru	Right	U	Left	Thru	Right	U	Left	Thru	Right	U	Left	Thru	Right	U		
11:40 AM	3	3	19	0	12	4	3	0	3	110	4	0	18	114	4	0	297	
11:45 AM	4	2	21	0	10	2	4	0	4	101	6	0	18	143	9	1	325	
11:50 AM	3	1	12	0	10	6	1	0	5	133	1	0	13	110	5	0	300	
11:55 AM	4	2	20	0	14	3	5	0	6	118	5	0	21	124	13	1	336	3590
12:00 PM	3	2	17	0	12	3	3	0	2	108	9	0	26	128	7	0	320	3602
12:05 PM	3	1	12	0	13	3	3	0	5	115	4	0	17	106	9	0	291	3617
12:10 PM	5	4	26	0	9	3	5	0	5	104	9	0	29	130	13	0	342	3663
12:15 PM	1	1	15	0	14	3	7	0	5	99	10	0	20	122	10	0	307	3687
12:20 PM	8	2	26	0	14	1	10	0	6	92	2	0	26	120	10	0	317	3717
12:25 PM	7	2	17	0	14	3	4	0	4	127	3	0	19	130	8	0	338	3776
12:30 PM	7	1	32	0	15	4	6	0	5	105	3	0	25	121	11	2	337	3803
12:35 PM	6	3	27	0	17	6	2	0	4	113	5	0	20	129	10	0	342	3852
12:40 PM	4	1	16	0	14	3	6	0	4	117	5	0	13	113	9	0	305	3860
12:45 PM	4	3	23	0	19	1	4	0	4	102	4	0	26	103	4	0	297	3832
12:50 PM	4	1	19	0	11	3	7	0	0	129	5	0	21	135	8	0	343	3875
12:55 PM	3	2	19	0	11	4	2	0	6	102	4	0	13	131	5	0	302	3841
1:00 PM	5	2	16	0	9	4	6	0	4	112	3	0	22	101	5	0	289	3810
1:05 PM	3	3	12	0	7	5	3	0	3	133	6	0	21	116	8	0	320	3839
1:10 PM	7	2	21	0	11	5	2	0	9	117	2	0	24	106	4	0	310	3807
1:15 PM	4	0	21	0	8	4	4	0	3	105	7	0	19	108	7	0	290	3790
1:20 PM	6	1	19	0	13	2	2	0	5	125	6	0	18	140	11	0	348	3821
1:25 PM	1	1	17	0	12	0	4	0	5	134	2	0	12	137	5	0	330	3813
1:30 PM	9	0	14	0	10	4	10	0	0	101	3	0	25	119	11	0	306	3782
1:35 PM	5	1	18	0	4	3	4	0	3	126	10	0	22	121	5	0	322	3762
Peak 15-Min Flowrates	Northbound				Southbound				Eastbound				Westbound				Total	
	Left	Thru	Right	U	Left	Thru	Right	U	Left	Thru	Right	U	Left	Thru	Right	U		
All Vehicles	80	24	304	0	184	52	48	0	52	1380	44	0	256	1520	116	8	4068	
Heavy Trucks	0	0	0		4	0	0		8	48	0		4	40	0		104	
Pedestrians						4				12				0			16	
Bicycles	0	0	0		0	0	0		0	0	0		0	0	0		0	
Railroad																		
Stopped Buses																		

Comments: N

LOCATION: SW 75th Ave -- SW Nyberg St
CITY/STATE: Tualatin, OR

QC JOB #: 10772108
DATE: Sat, Jun 09 2012

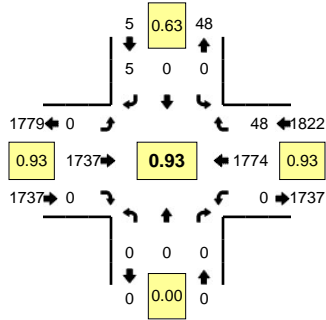

Peak-Hour: 12:10 PM -- 1:10 PM
Peak 15-Min: 12:25 PM -- 12:40 PM

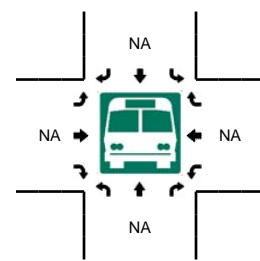
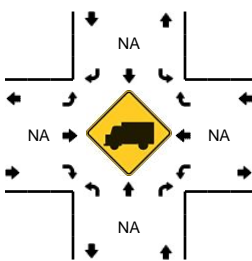
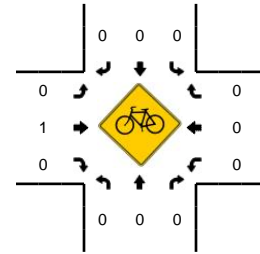
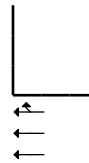
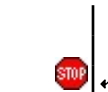
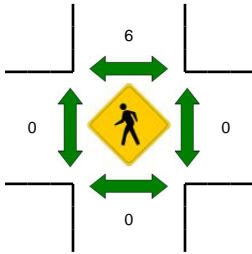
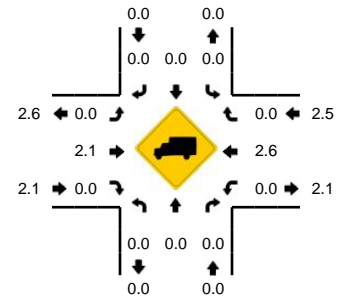

5-Min Count Period Beginning At	SW 75th Ave (Northbound)				SW 75th Ave (Southbound)				SW Nyberg St (Eastbound)				SW Nyberg St (Westbound)				Total	Hourly Totals
	Left	Thru	Right	U	Left	Thru	Right	U	Left	Thru	Right	U	Left	Thru	Right	U		
11:40 AM	0	0	0	0	0	0	0	0	0	141	0	0	0	147	6	0	294	
11:45 AM	0	0	0	0	0	0	0	0	0	132	0	0	0	167	6	0	305	
11:50 AM	0	0	0	0	0	0	0	0	0	155	0	0	0	137	5	0	297	
11:55 AM	0	0	0	0	0	0	0	0	0	152	0	0	0	155	2	0	309	3418
12:00 PM	0	0	0	0	0	0	0	0	0	137	0	0	0	161	1	0	299	3435
12:05 PM	0	0	0	0	0	0	0	0	0	140	0	0	0	137	3	0	280	3449
12:10 PM	0	0	0	0	0	0	0	0	0	139	0	0	0	157	5	0	301	3464
12:15 PM	0	0	0	0	0	0	0	0	0	128	0	0	0	161	0	0	289	3510
12:20 PM	0	0	0	0	0	0	0	1	0	132	0	0	0	145	2	0	280	3502
12:25 PM	0	0	0	0	0	0	0	0	0	158	0	0	0	161	3	0	322	3554
12:30 PM	0	0	0	0	0	0	0	1	0	152	0	0	0	164	4	0	321	3588
12:35 PM	0	0	0	0	0	0	0	0	0	157	0	0	0	150	7	0	314	3611
12:40 PM	0	0	0	0	0	0	0	1	0	147	0	0	0	125	4	0	277	3594
12:45 PM	0	0	0	0	0	0	0	0	0	144	0	0	0	132	5	0	281	3570
12:50 PM	0	0	0	0	0	0	0	1	0	159	0	0	0	159	2	0	321	3594
12:55 PM	0	0	0	0	0	0	0	0	0	132	0	0	0	156	5	0	293	3578
1:00 PM	0	0	0	0	0	0	0	1	0	137	0	0	0	114	6	0	258	3537
1:05 PM	0	0	0	0	0	0	0	0	0	152	0	0	0	150	5	0	307	3564
1:10 PM	0	0	0	0	0	0	0	0	0	149	0	0	0	133	5	0	287	3550
1:15 PM	0	0	0	0	0	0	0	0	0	134	0	0	0	133	6	0	273	3534
1:20 PM	0	0	0	0	0	0	0	0	0	157	0	0	0	165	4	0	326	3580
1:25 PM	0	0	0	0	0	0	0	1	0	163	0	0	0	138	7	0	309	3567
1:30 PM	0	0	0	0	0	0	0	0	0	125	0	0	0	152	3	0	280	3526
1:35 PM	0	0	0	0	0	0	0	2	0	148	0	0	0	133	5	0	288	3500
Peak 15-Min Flowrates	Northbound				Southbound				Eastbound				Westbound				Total	
	Left	Thru	Right	U	Left	Thru	Right	U	Left	Thru	Right	U	Left	Thru	Right	U		
All Vehicles	0	0	0	0	0	0	4	0	0	1868	0	0	0	1900	56	0	3828	
Heavy Trucks	0	0	0	0	0	0	0	0	0	52	0	0	0	44	0	0	96	
Pedestrians	0	0	0	0	0	4	0	0	0	0	0	0	0	0	0	0	4	
Bicycles	0	0	0	0	0	0	0	0	0	0	0	0	0	0	0	0	0	
Railroad	0	0	0	0	0	0	0	0	0	0	0	0	0	0	0	0	0	
Stopped Buses	0	0	0	0	0	0	0	0	0	0	0	0	0	0	0	0	0	

Comments: N

LOCATION: I-5 SB Ramp Terminal -- SW Nyberg St
CITY/STATE: Tualatin, OR

QC JOB #: 10772106
DATE: Sat, Jun 16 2012

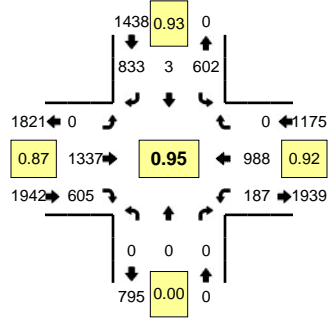

Peak-Hour: 12:10 PM -- 1:10 PM
Peak 15-Min: 12:50 PM -- 1:05 PM

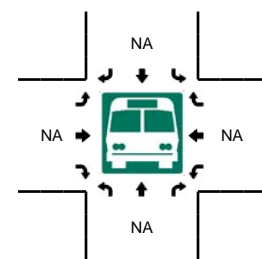
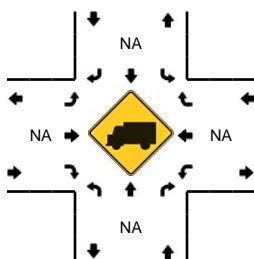
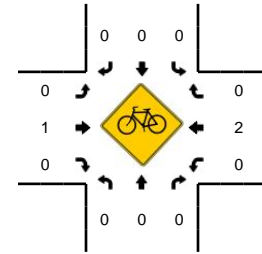
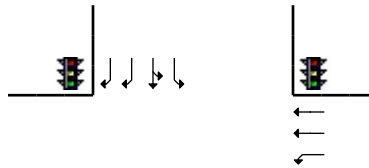
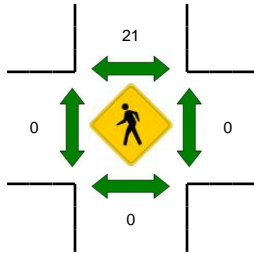
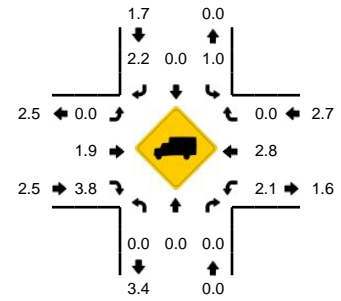

5-Min Count Period Beginning At	I-5 SB Ramp Terminal (Northbound)				I-5 SB Ramp Terminal (Southbound)				SW Nyberg St (Eastbound)				SW Nyberg St (Westbound)				Total	Hourly Totals
	Left	Thru	Right	U	Left	Thru	Right	U	Left	Thru	Right	U	Left	Thru	Right	U		
11:40 AM	0	0	0	0	39	0	82	0	0	80	57	0	6	77	0	0	341	
11:45 AM	0	0	0	0	32	1	49	0	0	100	44	0	13	87	0	0	326	
11:50 AM	0	0	0	0	54	0	90	0	0	103	55	0	10	80	0	0	392	
11:55 AM	0	0	0	0	39	0	68	0	0	99	49	0	15	75	0	0	345	4077
12:00 PM	0	0	0	0	30	0	58	0	0	109	52	0	12	99	0	0	360	4127
12:05 PM	0	0	0	0	47	0	57	0	0	81	53	0	17	59	0	0	314	4126
12:10 PM	0	0	0	0	47	0	75	0	0	136	50	0	11	92	0	0	411	4197
12:15 PM	0	0	0	0	41	0	71	0	0	105	41	0	18	100	0	0	376	4216
12:20 PM	0	0	0	0	49	0	74	0	0	90	44	0	19	79	0	0	355	4287
12:25 PM	0	0	0	0	44	0	63	0	0	115	43	0	12	74	0	0	351	4287
12:30 PM	0	0	0	0	55	1	55	0	0	90	54	0	20	60	0	0	335	4250
12:35 PM	0	0	0	0	54	1	74	0	0	127	47	0	12	93	0	0	408	4314
12:40 PM	0	0	0	0	51	0	67	0	0	112	54	0	15	102	0	0	401	4374
12:45 PM	0	0	0	0	55	0	72	0	0	105	51	0	22	57	0	0	362	4410
12:50 PM	0	0	0	0	39	0	64	0	0	144	60	0	13	89	0	0	409	4427
12:55 PM	0	0	0	0	68	0	71	0	0	106	54	0	19	69	0	0	387	4469
1:00 PM	0	0	0	0	34	1	58	0	0	131	62	0	8	103	0	0	397	4506
1:05 PM	0	0	0	0	65	0	89	0	0	76	45	0	18	70	0	0	363	4555
1:10 PM	0	0	0	0	48	1	67	0	0	102	64	0	10	89	0	0	381	4525
1:15 PM	0	0	0	0	50	0	67	0	0	95	50	0	19	75	0	0	356	4505
1:20 PM	0	0	0	0	64	0	74	0	0	92	56	0	13	63	0	0	362	4512
1:25 PM	0	0	0	0	53	0	68	0	0	105	44	0	11	95	0	0	376	4537
1:30 PM	0	0	0	0	59	0	74	0	0	112	49	0	11	81	0	0	386	4588
1:35 PM	0	0	0	0	60	0	87	0	0	89	51	0	21	57	0	0	365	4545
Peak 15-Min Flowrates	Northbound				Southbound				Eastbound				Westbound				Total	
	Left	Thru	Right	U	Left	Thru	Right	U	Left	Thru	Right	U	Left	Thru	Right	U		
All Vehicles	0	0	0	0	564	4	772	0	0	1524	704	0	160	1044	0	0	4772	
Heavy Trucks	0	0	0	0	4	0	8	0	0	24	16	0	4	24	0	0	80	
Pedestrians	0	0	0	0	16	0	0	0	0	0	0	0	0	0	0	0	16	
Bicycles	0	0	0	0	0	0	0	0	0	1	0	0	0	0	0	0	1	
Railroad	0	0	0	0	0	0	0	0	0	0	0	0	0	0	0	0	0	
Stopped Buses	0	0	0	0	0	0	0	0	0	0	0	0	0	0	0	0	0	

Comments: N

LOCATION: I-5 NB Ramp Terminal -- SW Nyberg St
CITY/STATE: Tualatin, OR

QC JOB #: 10772104
DATE: Sat, Jun 16 2012

Peak-Hour: 12:10 PM -- 1:10 PM
Peak 15-Min: 12:45 PM -- 1:00 PM

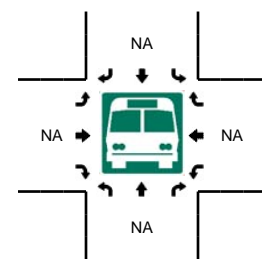
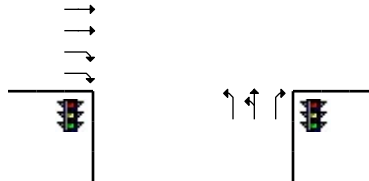
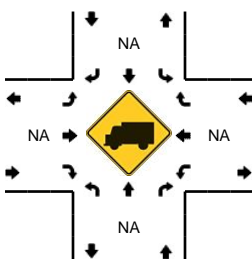
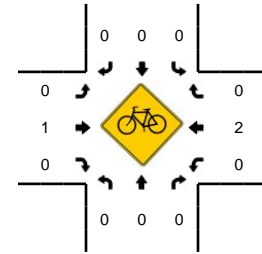
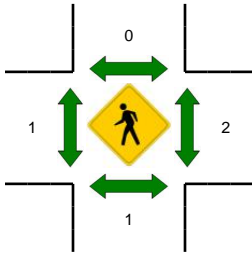
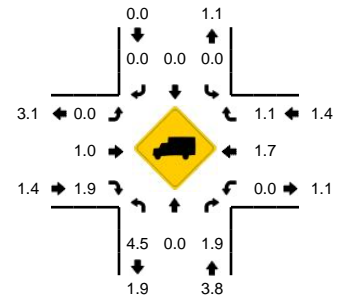
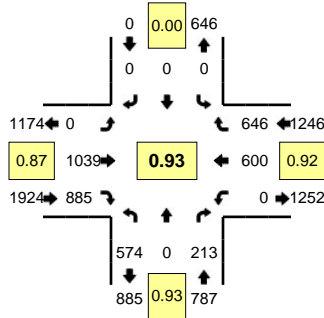

5-Min Count Period Beginning At	I-5 NB Ramp Terminal (Northbound)				I-5 NB Ramp Terminal (Southbound)				SW Nyberg St (Eastbound)				SW Nyberg St (Westbound)				Total	Hourly Totals
	Left	Thru	Right	U	Left	Thru	Right	U	Left	Thru	Right	U	Left	Thru	Right	U		
11:40 AM	40	0	23	0	0	0	0	0	0	55	62	0	0	43	50	0	273	
11:45 AM	63	0	19	0	0	0	0	0	0	62	58	0	0	36	57	0	295	
11:50 AM	49	0	15	0	0	0	0	0	0	82	72	0	0	42	58	0	318	
11:55 AM	35	0	20	0	0	0	0	0	0	83	69	0	0	50	36	0	293	3449
12:00 PM	63	0	17	0	0	0	0	0	0	69	66	0	0	46	55	0	316	3498
12:05 PM	36	0	15	0	0	0	0	0	0	71	61	0	0	51	61	0	295	3558
12:10 PM	55	0	17	0	0	0	0	0	0	82	81	0	0	40	50	0	325	3605
12:15 PM	67	0	13	0	0	0	0	0	0	86	63	0	0	48	43	0	320	3616
12:20 PM	36	0	15	0	0	0	0	0	0	82	64	0	0	62	41	0	300	3654
12:25 PM	38	0	22	0	0	0	0	0	0	79	64	0	0	45	66	0	314	3687
12:30 PM	28	0	13	0	0	0	0	0	0	99	63	0	0	58	66	0	327	3705
12:35 PM	57	0	21	0	0	0	0	0	0	87	79	0	0	44	50	0	338	3714
12:40 PM	60	0	13	0	0	0	0	0	0	83	57	0	0	55	55	0	323	3764
12:45 PM	33	0	21	0	0	0	0	0	0	101	95	0	0	47	56	0	353	3822
12:50 PM	53	0	25	0	0	0	0	0	0	66	91	0	0	41	60	0	336	3840
12:55 PM	40	0	20	0	0	0	0	0	0	101	97	0	0	59	56	0	373	3920
1:00 PM	59	0	15	0	0	0	0	0	0	84	73	0	0	48	44	0	323	3927
1:05 PM	48	0	18	0	0	0	0	0	0	89	58	0	0	53	59	0	325	3957
1:10 PM	42	0	18	0	0	0	0	0	0	72	72	0	0	47	51	0	302	3934
1:15 PM	51	0	13	0	0	0	0	0	0	89	39	0	0	45	46	0	283	3897
1:20 PM	41	0	23	0	0	0	0	0	0	100	81	0	0	43	59	0	347	3944
1:25 PM	51	0	21	0	0	0	0	0	0	79	67	0	0	41	43	0	302	3932
1:30 PM	49	0	15	0	0	0	0	0	0	91	67	0	0	43	49	0	314	3919
1:35 PM	37	0	22	0	0	0	0	0	0	104	74	0	0	48	50	0	335	3916
Peak 15-Min Flowrates	Northbound				Southbound				Eastbound				Westbound				Total	
	Left	Thru	Right	U	Left	Thru	Right	U	Left	Thru	Right	U	Left	Thru	Right	U		
All Vehicles	504	0	264	0	0	0	0	0	0	1072	1132	0	0	588	688	0	4248	
Heavy Trucks	16	0	4	0	0	0	0	0	0	8	16	0	0	24	8	0	76	
Pedestrians			4				0				4			4			12	
Bicycles			0				0				1	0		0	0		1	
Railroad																		
Stopped Buses																		

Comments: N

LOCATION: Signalized Entrance to Nyberg Woods -- SW Nyberg St
CITY/STATE: Tualatin, OR

QC JOB #: 10772102
DATE: Sat, Jun 09 2012

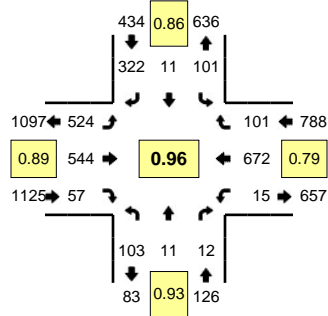

Peak-Hour: 12:10 PM -- 1:10 PM
Peak 15-Min: 12:35 PM -- 12:50 PM

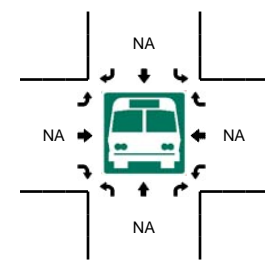
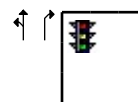
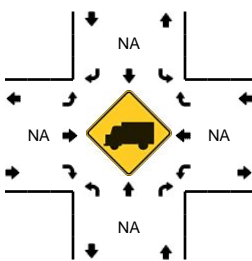
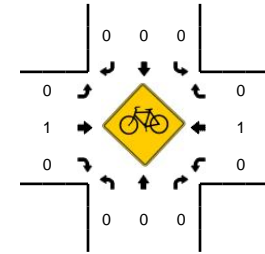
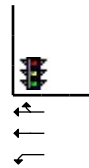
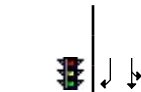
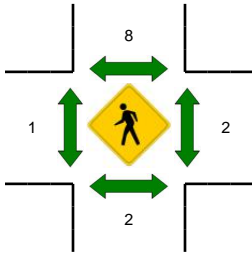
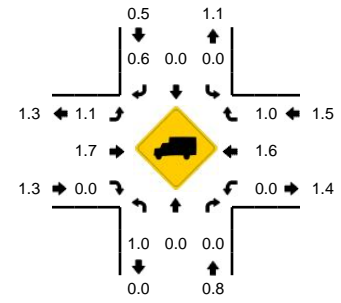

5-Min Count Period Beginning At	Signalized Entrance to Nyberg Woods (Northbound)				Signalized Entrance to Nyberg Woods (Southbound)				SW Nyberg St (Eastbound)				SW Nyberg St (Westbound)				Total	Hourly Totals
	Left	Thru	Right	U	Left	Thru	Right	U	Left	Thru	Right	U	Left	Thru	Right	U		
11:40 AM	3	0	1	0	13	0	21	0	41	41	4	0	1	49	8	0	182	
11:45 AM	3	4	0	0	9	2	20	0	22	45	4	1	0	46	17	0	173	
11:50 AM	7	1	0	0	8	0	23	0	32	43	5	0	2	54	12	0	187	
11:55 AM	7	1	1	0	5	0	25	0	45	44	6	0	0	55	7	0	196	2141
12:00 PM	10	1	1	0	6	3	31	0	27	47	3	0	0	64	11	0	204	2170
12:05 PM	8	0	2	0	8	2	19	0	58	44	7	1	1	77	10	0	237	2239
12:10 PM	12	1	0	0	5	0	28	0	34	38	4	0	0	82	11	0	215	2310
12:15 PM	9	2	0	0	6	2	26	0	41	34	3	0	1	77	6	0	207	2327
12:20 PM	5	1	0	0	13	1	28	0	46	39	6	0	1	56	14	0	210	2348
12:25 PM	9	0	3	0	8	1	28	0	32	44	4	0	2	62	13	0	206	2377
12:30 PM	8	2	2	0	5	0	26	0	39	42	6	0	0	53	8	0	191	2393
12:35 PM	8	0	1	0	10	0	29	0	61	37	7	0	3	51	15	0	222	2430
12:40 PM	11	1	1	0	13	1	33	0	44	54	4	0	1	42	8	0	213	2461
12:45 PM	5	1	1	0	8	0	30	0	42	43	6	0	2	67	4	0	209	2497
12:50 PM	10	1	0	0	11	1	29	0	57	53	2	0	1	33	8	0	206	2516
12:55 PM	2	0	1	0	4	1	15	0	43	55	7	0	0	58	4	0	190	2510
1:00 PM	12	1	2	0	12	2	25	0	44	51	3	0	2	42	5	0	201	2507
1:05 PM	12	1	1	0	6	2	25	0	41	54	5	0	2	49	5	0	203	2473
1:10 PM	10	3	3	0	5	0	31	0	34	50	2	0	0	38	6	0	182	2440
1:15 PM	9	3	0	0	8	0	24	0	34	54	7	0	2	52	9	0	202	2435
1:20 PM	5	2	1	0	2	1	32	0	46	47	1	0	2	48	12	0	199	2424
1:25 PM	10	0	0	0	8	1	25	0	45	50	5	0	1	36	10	0	191	2409
1:30 PM	6	1	1	0	5	0	32	0	26	58	1	0	2	44	5	0	181	2399
1:35 PM	5	2	0	0	6	0	28	0	29	45	6	0	0	45	6	0	172	2349
Peak 15-Min Flowrates	Northbound				Southbound				Eastbound				Westbound				Total	
	Left	Thru	Right	U	Left	Thru	Right	U	Left	Thru	Right	U	Left	Thru	Right	U		
All Vehicles	96	8	12	0	124	4	368	0	588	536	68	0	24	640	108	0	2576	
Heavy Trucks	0	0	0	0	0	0	0	0	8	4	0	0	0	20	0	0	32	
Pedestrians		4				16				0				8			28	
Bicycles	0	0	0	0	0	0	0	0	0	0	0	0	0	0	0	0	0	
Railroad																		
Stopped Buses																		

Comments: N

Appendix C
Description of Level-of-Service
Methods and Criteria

APPENDIX C LEVEL-OF-SERVICE CONCEPT

Level of service (LOS) is a concept developed to quantify the degree of comfort (including such elements as travel time, number of stops, total amount of stopped delay, and impediments caused by other vehicles) afforded to drivers as they travel through an intersection or roadway segment. Six grades are used to denote the various level of service from “A” to “F”.¹

SIGNALIZED INTERSECTIONS

The six level-of-service grades are described qualitatively for signalized intersections in Table C1. Additionally, Table C2 identifies the relationship between level of service and average control delay per vehicle. Control delay is defined to include initial deceleration delay, queue move-up time, stopped delay, and final acceleration delay. Using this definition, Level of Service “D” is generally considered to represent the minimum acceptable design standard.

Table C-1 Level-of-Service Definitions (Signalized Intersections)

Level of Service	Average Delay per Vehicle
A	Very low average control delay, less than 10 seconds per vehicle. This occurs when progression is extremely favorable, and most vehicles arrive during the green phase. Most vehicles do not stop at all. Short cycle lengths may also contribute to low delay.
B	Average control delay is greater than 10 seconds per vehicle and less than or equal to 20 seconds per vehicle. This generally occurs with good progression and/or short cycle lengths. More vehicles stop than for a level of service A, causing higher levels of average delay.
C	Average control delay is greater than 20 seconds per vehicle and less than or equal to 35 seconds per vehicle. These higher delays may result from fair progression and/or longer cycle lengths. Individual cycle failures may begin to appear at this level. The number of vehicles stopping is significant at this level, although many still pass through the intersection without stopping.
D	Average control delay is greater than 35 seconds per vehicle and less than or equal to 55 seconds per vehicle. The influence of congestion becomes more noticeable. Longer delays may result from some combination of unfavorable progression, long cycle length, or high volume/capacity ratios. Many vehicles stop, and the proportion of vehicles not stopping declines. Individual cycle failures are noticeable.
E	Average control delay is greater than 55 seconds per vehicle and less than or equal to 80 seconds per vehicle. This is usually considered to be the limit of acceptable delay. These high delay values generally (but not always) indicate poor progression, long cycle lengths, and high volume/capacity ratios. Individual cycle failures are frequent occurrences.
F	Average control delay is in excess of 80 seconds per vehicle. This is considered to be unacceptable to most drivers. This condition often occurs with oversaturation. It may also occur at high volume/capacity ratios below 1.0 with many individual cycle failures. Poor progression and long cycle lengths may also contribute to such high delay values.

¹ Most of the material in this appendix is adapted from the Transportation Research Board, *Highway Capacity Manual*, (2000).

Table C2 Level-of-Service Criteria for Signalized Intersections

Level of Service	Average Control Delay per Vehicle (Seconds)
A	<10.0
B	>10 and ≤20
C	>20 and ≤35
D	>35 and ≤55
E	>55 and ≤80
F	>80

UNSIGNALIZED INTERSECTIONS

Unsignalized intersections include two-way stop-controlled (TWSC) and all-way stop-controlled (AWSC) intersections. The 2000 *Highway Capacity Manual* (HCM) provides models for estimating control delay at both TWSC and AWSC intersections. A qualitative description of the various service levels associated with an unsignalized intersection is presented in Table C3. A quantitative definition of level of service for unsignalized intersections is presented in Table C4. Using this definition, Level of Service “E” is generally considered to represent the minimum acceptable design standard.

Table C3 Level-of-Service Criteria for Unsignalized Intersections

Level of Service	Average Delay per Vehicle to Minor Street
A	<ul style="list-style-type: none"> Nearly all drivers find freedom of operation. Very seldom is there more than one vehicle in queue.
B	<ul style="list-style-type: none"> Some drivers begin to consider the delay an inconvenience. Occasionally there is more than one vehicle in queue.
C	<ul style="list-style-type: none"> Many times there is more than one vehicle in queue. Most drivers feel restricted, but not objectionably so.
D	<ul style="list-style-type: none"> Often there is more than one vehicle in queue. Drivers feel quite restricted.
E	<ul style="list-style-type: none"> Represents a condition in which the demand is near or equal to the probable maximum number of vehicles that can be accommodated by the movement. There is almost always more than one vehicle in queue. Drivers find the delays approaching intolerable levels.
F	<ul style="list-style-type: none"> Forced flow. Represents an intersection failure condition that is caused by geometric and/or operational constraints external to the intersection.

Table C4 Level-of-Service Criteria for Unsignalized Intersections

Level of Service	Average Control Delay per Vehicle (Seconds)
A	<10.0
B	>10.0 and ≤ 15.0
C	>15.0 and ≤ 25.0
D	>25.0 and ≤ 35.0
E	>35.0 and ≤ 50.0
F	>50.0





















It should be noted that the level-of-service criteria for unsignalized intersections are somewhat different than the criteria used for signalized intersections. The primary reason for this difference is that drivers expect different levels of performance from different kinds of transportation facilities. The expectation is that a signalized intersection is designed to carry higher traffic volumes than an unsignalized intersection. Additionally, there are a number of driver behavior considerations that combine to make delays at signalized intersections less galling than at unsignalized intersections. For example, drivers at signalized intersections are able to relax during the red interval, while drivers on the minor street approaches to TWSC intersections must remain attentive to the task of identifying acceptable gaps and vehicle conflicts. Also, there is often much more variability in the amount of delay experienced by individual drivers at unsignalized intersections than signalized intersections. For these reasons, it is considered that the control delay threshold for any given level of service is less for an unsignalized intersection than for a signalized intersection. While overall intersection level of service is calculated for AWSC intersections, level of service is only calculated for the minor approaches and the major street left turn movements at TWSC intersections. No delay is assumed to the major street through movements. For TWSC intersections, the overall intersection level of service remains undefined: level of service is only calculated for each minor street lane.

In the performance evaluation of TWSC intersections, it is important to consider other measures of effectiveness (MOEs) in addition to delay, such as v/c ratios for individual movements, average queue lengths, and 95th-percentile queue lengths. By focusing on a single MOE for the worst movement only, such as delay for the minor-street left turn, users may make inappropriate traffic control decisions. The potential for making such inappropriate decisions is likely to be particularly pronounced when the HCM level-of-service thresholds are adopted as legal standards, as is the case in many public agencies.

Appendix D
Existing Operations Worksheets

HCM Signalized Intersection Capacity Analysis
 1: Lower Boones Ferry Rd & SW Upper Boones Ferry Rd















4/15/2013

												
Movement	EBL	EBT	EBR	WBL	WBT	WBR	NBL	NBT	NBR	SBL	SBT	SBR
Lane Configurations												
Volume (vph)	1	7	9	455	7	39	0	470	541	57	656	1
Ideal Flow (vphpl)	1900	1900	1900	1900	1900	1900	1900	1900	1900	1900	1900	1900
Total Lost time (s)		3.5		3.5	3.5			4.0	3.5	3.5	4.0	
Lane Util. Factor		1.00		1.00	1.00			1.00	1.00	1.00	1.00	
Frbp, ped/bikes		0.94		1.00	1.00			1.00	0.99	1.00	1.00	
Flpb, ped/bikes		1.00		1.00	1.00			1.00	1.00	1.00	1.00	
Frt		0.93		1.00	0.87			1.00	0.85	1.00	1.00	
Flt Protected		1.00		0.95	1.00			1.00	1.00	0.95	1.00	
Satd. Flow (prot)		1655		1752	1657			1845	1567	1770	1881	
Flt Permitted		1.00		0.95	1.00			1.00	1.00	0.95	1.00	
Satd. Flow (perm)		1655		1752	1657			1845	1567	1770	1881	
Peak-hour factor, PHF	0.96	0.96	0.96	0.96	0.96	0.96	0.96	0.96	0.96	0.96	0.96	0.96
Adj. Flow (vph)	1	7	9	474	7	41	0	490	564	59	683	1
RTOR Reduction (vph)	0	9	0	0	25	0	0	0	153	0	0	0
Lane Group Flow (vph)	0	8	0	474	23	0	0	490	411	59	684	0
Confl. Peds. (#/hr)			5	5			12		1	1		12
Heavy Vehicles (%)	0%	0%	0%	3%	0%	0%	0%	3%	2%	2%	1%	0%
Turn Type	Split			Split			Prot		pm+ov		Prot	
Protected Phases	8	8		4	4		1	6	4	5	2	
Permitted Phases									6			
Actuated Green, G (s)		1.7		32.1	32.1			27.0	59.1	5.2	36.2	
Effective Green, g (s)		2.2		32.6	32.6			27.5	60.1	5.7	36.7	
Actuated g/C Ratio		0.03		0.40	0.40			0.33	0.73	0.07	0.44	
Clearance Time (s)		4.0		4.0	4.0			4.5	4.0	4.0	4.5	
Vehicle Extension (s)		2.5		2.2	2.2			3.5	2.2	2.2	3.5	
Lane Grp Cap (vph)		44		692	655			615	1142	122	837	
v/s Ratio Prot		c0.00		c0.27	0.01			0.27	0.14	0.03	c0.36	
v/s Ratio Perm									0.12			
v/c Ratio		0.19		0.68	0.04			0.80	0.36	0.48	0.82	
Uniform Delay, d1		39.3		20.7	15.3			25.0	4.1	37.0	20.0	
Progression Factor		1.00		1.00	1.00			1.00	1.00	1.00	1.00	
Incremental Delay, d2		1.5		2.4	0.0			7.3	0.1	1.5	6.4	
Delay (s)		40.8		23.1	15.3			32.3	4.2	38.5	26.4	
Level of Service		D		C	B			C	A	D	C	
Approach Delay (s)		40.8			22.4			17.3			27.3	
Approach LOS		D			C			B			C	
Intersection Summary												
HCM Average Control Delay			21.8			HCM Level of Service				C		
HCM Volume to Capacity ratio			0.74									
Actuated Cycle Length (s)			82.5			Sum of lost time (s)			11.0			
Intersection Capacity Utilization			79.8%			ICU Level of Service				D		
Analysis Period (min)			15									
c Critical Lane Group												

HCM Signalized Intersection Capacity Analysis

2: SW Boones Ferry Rd & SW Tualatin Rd

4/15/2013

						
Movement	WBL	WBR	NBT	NBR	SBL	SBT
Lane Configurations	 				 	
Volume (vph)	398	810	194	289	430	354
Ideal Flow (vphpl)	1900	1900	1900	1900	1900	1900
Total Lost time (s)	3.5	3.5	3.0	3.5	3.5	3.5
Lane Util. Factor	0.97	1.00	1.00	1.00	1.00	1.00
Frpb, ped/bikes	1.00	1.00	1.00	1.00	1.00	1.00
Flpb, ped/bikes	1.00	1.00	1.00	1.00	1.00	1.00
Fr t	1.00	0.85	1.00	0.85	1.00	1.00
Fl t Protected	0.95	1.00	1.00	1.00	0.95	1.00
Satd. Flow (prot)	3433	1583	1881	1553	1787	1881
Fl t Permitted	0.95	1.00	1.00	1.00	0.95	1.00
Satd. Flow (perm)	3433	1583	1881	1553	1787	1881
Peak-hour factor, PHF	0.96	0.96	0.96	0.96	0.96	0.96
Adj. Flow (vph)	415	844	202	301	448	369
RTOR Reduction (vph)	0	208	0	84	0	0
Lane Group Flow (vph)	415	636	202	217	448	369
Confl. Peds. (#/hr)	2					
Heavy Vehicles (%)	2%	2%	1%	4%	1%	1%
Turn Type		pm+ov		pm+ov	Prot	
Protected Phases	8	1	2	8	1	6
Permitted Phases		8		2		
Actuated Green, G (s)	11.2	29.9	10.5	21.7	18.7	32.7
Effective Green, g (s)	11.7	30.9	11.0	22.7	19.2	33.2
Actuated g/C Ratio	0.23	0.60	0.21	0.44	0.37	0.64
Clearance Time (s)	4.0	4.0	3.5	4.0	4.0	4.0
Vehicle Extension (s)	3.0	2.0	5.0	3.0	2.0	2.0
Lane Grp Cap (vph)	774	1049	399	679	661	1203
v/s Ratio Prot	0.12	c0.22	c0.11	0.07	0.25	0.20
v/s Ratio Perm		0.18		0.07		
v/c Ratio	0.54	0.61	0.51	0.32	0.68	0.31
Uniform Delay, d1	17.7	6.6	18.1	9.6	13.7	4.2
Progression Factor	1.00	1.00	1.00	1.00	1.00	1.00
Incremental Delay, d2	0.7	0.7	2.1	0.3	2.2	0.1
Delay (s)	18.4	7.3	20.2	9.8	15.9	4.2
Level of Service	B	A	C	A	B	A
Approach Delay (s)	11.0		14.0			10.7
Approach LOS	B		B			B
Intersection Summary						
HCM Average Control Delay			11.5		HCM Level of Service	B
HCM Volume to Capacity ratio			0.58			
Actuated Cycle Length (s)			51.9		Sum of lost time (s)	6.5
Intersection Capacity Utilization			67.0%		ICU Level of Service	C
Analysis Period (min)			15			
c Critical Lane Group						

HCM Signalized Intersection Capacity Analysis
 3: SW Boones Fe & SW Martinazzi Ave

4/15/2013

	→	↘	↙	←	↖	↗
Movement	EBT	EBR	WBL	WBT	NBL	NBR
Lane Configurations	↑	↗	↘	↑	↘	↗
Volume (vph)	645	170	410	903	320	380
Ideal Flow (vphpl)	1900	1900	1900	1900	1900	1900
Total Lost time (s)	4.5	4.5	4.5	4.5	4.5	4.5
Lane Util. Factor	1.00	1.00	1.00	1.00	1.00	1.00
Frbp, ped/bikes	1.00	1.00	1.00	1.00	1.00	0.98
Flpb, ped/bikes	1.00	1.00	1.00	1.00	1.00	1.00
Frt	1.00	0.85	1.00	1.00	1.00	0.85
Flt Protected	1.00	1.00	0.95	1.00	0.95	1.00
Satd. Flow (prot)	1863	1599	1787	1845	1770	1572
Flt Permitted	1.00	1.00	0.95	1.00	0.95	1.00
Satd. Flow (perm)	1863	1599	1787	1845	1770	1572
Peak-hour factor, PHF	0.95	0.95	0.95	0.95	0.95	0.95
Adj. Flow (vph)	679	179	432	951	337	400
RTOR Reduction (vph)	0	51	0	0	0	41
Lane Group Flow (vph)	679	128	432	951	337	359
Confl. Peds. (#/hr)		7	7		7	8
Confl. Bikes (#/hr)	4		2	10	1	
Heavy Vehicles (%)	2%	1%	1%	3%	2%	1%
Turn Type		Prot	Prot			pm+ov
Protected Phases	2	2	1	6	8	1
Permitted Phases					8	8
Actuated Green, G (s)	41.2	41.2	29.2	75.4	21.1	50.3
Effective Green, g (s)	41.7	41.7	29.7	75.9	21.6	51.3
Actuated g/C Ratio	0.39	0.39	0.28	0.71	0.20	0.48
Clearance Time (s)	5.0	5.0	5.0	5.0	5.0	5.0
Vehicle Extension (s)	3.0	3.0	3.0	3.0	3.0	3.0
Lane Grp Cap (vph)	729	626	498	1315	359	824
v/s Ratio Prot	c0.36	0.08	c0.24	0.52	c0.19	0.12
v/s Ratio Perm						0.11
v/c Ratio	0.93	0.20	0.87	0.72	0.94	0.44
Uniform Delay, d1	31.0	21.4	36.5	9.1	41.8	18.1
Progression Factor	1.00	1.00	1.00	1.00	1.00	1.00
Incremental Delay, d2	18.6	0.2	14.7	2.0	31.7	0.4
Delay (s)	49.6	21.6	51.3	11.1	73.5	18.5
Level of Service	D	C	D	B	E	B
Approach Delay (s)	43.8			23.6	43.6	
Approach LOS	D			C	D	

Intersection Summary			
HCM Average Control Delay	34.4	HCM Level of Service	C
HCM Volume to Capacity ratio	0.91		
Actuated Cycle Length (s)	106.5	Sum of lost time (s)	13.5
Intersection Capacity Utilization	85.6%	ICU Level of Service	E
Analysis Period (min)	15		

c Critical Lane Group

HCM Unsignalized Intersection Capacity Analysis

4: Site Entrance 1 & Martinazzi Ave

4/15/2013



Movement	WBL	WBR	NBT	NBR	SBL	SBT
Lane Configurations	↶	↷	↷		↶	↷
Volume (veh/h)	30	100	580	60	142	438
Sign Control	Stop		Free			Free
Grade	0%		0%			0%
Peak Hour Factor	0.91	0.91	0.91	0.91	0.91	0.91
Hourly flow rate (vph)	33	110	637	66	156	481
Pedestrians	25		16			26
Lane Width (ft)	12.0		12.0			12.0
Walking Speed (ft/s)	4.0		4.0			4.0
Percent Blockage	2		1			2
Right turn flare (veh)						
Median type			None			TWLTL
Median storage (veh)						2
Upstream signal (ft)			428			355
pX, platoon unblocked	0.90	0.90			0.90	
vC, conflicting volume	1505	721			728	
vC1, stage 1 conf vol	695					
vC2, stage 2 conf vol	809					
vCu, unblocked vol	1505	630			638	
tC, single (s)	6.4	6.2			4.1	
tC, 2 stage (s)	5.4					
tF (s)	3.5	3.3			2.2	
p0 queue free %	89	74			81	
cM capacity (veh/h)	292	416			838	
Direction, Lane #	WB 1	WB 2	NB 1	SB 1	SB 2	
Volume Total	33	110	703	156	481	
Volume Left	33	0	0	156	0	
Volume Right	0	110	66	0	0	
cSH	292	416	1700	838	1700	
Volume to Capacity	0.11	0.26	0.41	0.19	0.28	
Queue Length 95th (ft)	10	27	0	18	0	
Control Delay (s)	18.9	16.7	0.0	10.3	0.0	
Lane LOS	C	C		B		
Approach Delay (s)	17.2		0.0	2.5		
Approach LOS	C					
Intersection Summary						
Average Delay			2.7			
Intersection Capacity Utilization			61.4%		ICU Level of Service	B
Analysis Period (min)			15			

HCM Unsignalized Intersection Capacity Analysis

5: Seneca St & Martinazzi Ave

4/15/2013

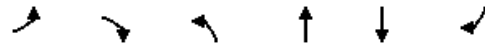

Movement	EBL	EBR	NBL	NBT	SBT	SBR
Lane Configurations	Y		Y	↑	↑	
Volume (veh/h)	42	80	80	600	418	50
Sign Control	Stop			Free	Free	
Grade	0%			0%	0%	
Peak Hour Factor	0.89	0.89	0.89	0.89	0.89	0.89
Hourly flow rate (vph)	47	90	90	674	470	56
Pedestrians						
Lane Width (ft)						
Walking Speed (ft/s)						
Percent Blockage						
Right turn flare (veh)						
Median type				None	None	
Median storage (veh)						
Upstream signal (ft)				308	475	
pX, platoon unblocked	0.88					
vC, conflicting volume	1352	498	526			
vC1, stage 1 conf vol						
vC2, stage 2 conf vol						
vCu, unblocked vol	1332	498	526			
tC, single (s)	6.4	6.2	4.1			
tC, 2 stage (s)						
tF (s)	3.5	3.3	2.2			
p0 queue free %	66	84	91			
cM capacity (veh/h)	139	577	1051			
Direction, Lane #	EB 1	NB 1	NB 2	SB 1		
Volume Total	137	90	674	526		
Volume Left	47	90	0	0		
Volume Right	90	0	0	56		
cSH	276	1051	1700	1700		
Volume to Capacity	0.50	0.09	0.40	0.31		
Queue Length 95th (ft)	67	7	0	0		
Control Delay (s)	30.2	8.7	0.0	0.0		
Lane LOS	D	A				
Approach Delay (s)	30.2	1.0		0.0		
Approach LOS	D					
Intersection Summary						
Average Delay			3.5			
Intersection Capacity Utilization			46.7%		ICU Level of Service	A
Analysis Period (min)			15			

HCM Unsignalized Intersection Capacity Analysis
6: Site Entrance 2 & Martinazzi Ave

4/15/2013



Movement	WBL	WBR	NBT	NBR	SBL	SBT
Lane Configurations						
Volume (veh/h)	0	32	650	6	10	488
Sign Control	Stop		Free			Free
Grade	0%		0%			0%
Peak Hour Factor	0.91	0.91	0.91	0.91	0.91	0.91
Hourly flow rate (vph)	0	35	714	7	11	536
Pedestrians	25		16			26
Lane Width (ft)	12.0		12.0			12.0
Walking Speed (ft/s)	4.0		4.0			4.0
Percent Blockage	2		1			2
Right turn flare (veh)						
Median type			None			None
Median storage (veh)						
Upstream signal (ft)			227			556
pX, platoon unblocked	0.85	0.85			0.85	
vC, conflicting volume	1049	769			746	
vC1, stage 1 conf vol						
vC2, stage 2 conf vol						
vCu, unblocked vol	969	639			612	
tC, single (s)	6.8	6.9			4.1	
tC, 2 stage (s)						
tF (s)	3.5	3.3			2.2	
p0 queue free %	100	90			99	
cM capacity (veh/h)	206	345			812	
Direction, Lane #	WB 1	NB 1	SB 1	SB 2		
Volume Total	35	721	190	358		
Volume Left	0	0	11	0		
Volume Right	35	7	0	0		
cSH	345	1700	812	1700		
Volume to Capacity	0.10	0.42	0.01	0.21		
Queue Length 95th (ft)	9	0	1	0		
Control Delay (s)	16.6	0.0	0.7	0.0		
Lane LOS	C		A			
Approach Delay (s)	16.6	0.0	0.2			
Approach LOS	C					
Intersection Summary						
Average Delay			0.5			
Intersection Capacity Utilization			50.8%		ICU Level of Service	A
Analysis Period (min)			15			

HCM Unsignalized Intersection Capacity Analysis

7: RO Only & Martinazzi Ave

4/15/2013



Movement	WBL	WBR	NBT	NBR	SBL	SBT
Lane Configurations		↗	↑			↘↘
Volume (veh/h)	0	12	655	0	0	488
Sign Control	Stop		Free			Free
Grade	0%		0%			0%
Peak Hour Factor	0.89	0.89	0.89	0.89	0.89	0.89
Hourly flow rate (vph)	0	13	736	0	0	548
Pedestrians						
Lane Width (ft)						
Walking Speed (ft/s)						
Percent Blockage						
Right turn flare (veh)						
Median type	None			None		
Median storage (veh)						
Upstream signal (ft)	125			658		
pX, platoon unblocked	0.84	0.84			0.84	
vC, conflicting volume	1010	736			736	
vC1, stage 1 conf vol						
vC2, stage 2 conf vol						
vCu, unblocked vol	918	592			592	
tC, single (s)	6.8	6.9			4.1	
tC, 2 stage (s)						
tF (s)	3.5	3.3			2.2	
p0 queue free %	100	96			100	
cM capacity (veh/h)	231	382			836	





















Direction, Lane #	WB 1	NB 1	SB 1	SB 2
Volume Total	13	736	274	274
Volume Left	0	0	0	0
Volume Right	13	0	0	0
cSH	382	1700	1700	1700
Volume to Capacity	0.04	0.43	0.16	0.16
Queue Length 95th (ft)	3	0	0	0
Control Delay (s)	14.8	0.0	0.0	0.0
Lane LOS	B			
Approach Delay (s)	14.8	0.0	0.0	
Approach LOS	B			

Intersection Summary			
Average Delay		0.2	
Intersection Capacity Utilization		44.5%	ICU Level of Service A
Analysis Period (min)		15	

HCM Signalized Intersection Capacity Analysis

8: Nyberg St & Martinazzi Ave

4/15/2013

													
Movement	EBL	EBT	EBR	WBL	WBT	WBR	NBL	NBT	NBR	SBL	SBT	SBR	
Lane Configurations													
Volume (vph)	29	10	101	338	55	327	27	299	19	0	478	10	
Ideal Flow (vphpl)	1900	1900	1900	1900	1900	1900	1900	1900	1900	1900	1900	1900	
Total Lost time (s)	5.5	5.5		5.5	5.5	5.5	5.5	5.5			5.5		
Lane Util. Factor	1.00	1.00		0.95	0.95	1.00	1.00	1.00			0.95		
Frbp, ped/bikes	1.00	1.00		1.00	1.00	0.96	1.00	1.00			1.00		
Flpb, ped/bikes	1.00	1.00		1.00	1.00	1.00	1.00	1.00			1.00		
Frt	1.00	0.86		1.00	1.00	0.85	1.00	0.99			1.00		
Flt Protected	0.95	1.00		0.95	0.97	1.00	0.95	1.00			1.00		
Satd. Flow (prot)	1805	1626		1698	1730	1526	1681	1860			3562		
Flt Permitted	0.95	1.00		0.95	0.97	1.00	0.43	1.00			1.00		
Satd. Flow (perm)	1805	1626		1698	1730	1526	768	1860			3562		
Peak-hour factor, PHF	0.91	0.91	0.91	0.91	0.91	0.91	0.91	0.91	0.91	0.91	0.91	0.91	
Adj. Flow (vph)	32	11	111	371	60	359	30	329	21	0	525	11	
RTOR Reduction (vph)	0	98	0	0	0	276	0	3	0	0	2	0	
Lane Group Flow (vph)	32	24	0	215	216	83	30	347	0	0	534	0	
Confl. Peds. (#/hr)	10					10	6		19	19		6	
Confl. Bikes (#/hr)						2						3	
Heavy Vehicles (%)	0%	0%	1%	1%	0%	2%	7%	1%	0%	0%	1%	0%	
Turn Type	Split			Split			Perm	Perm					
Protected Phases	8	8		4	4			6				2	
Permitted Phases						4	6						
Actuated Green, G (s)	4.8	4.8		10.4	10.4	10.4	13.8	13.8				13.8	
Effective Green, g (s)	5.3	5.3		10.9	10.9	10.9	14.3	14.3				14.3	
Actuated g/C Ratio	0.11	0.11		0.23	0.23	0.23	0.30	0.30				0.30	
Clearance Time (s)	6.0	6.0		6.0	6.0	6.0	6.0	6.0				6.0	
Vehicle Extension (s)	2.5	2.5		2.5	2.5	2.5	5.0	5.0				5.0	
Lane Grp Cap (vph)	204	183		394	401	354	234	566				1084	
v/s Ratio Prot	c0.02	0.01		c0.13	0.12			c0.19				0.15	
v/s Ratio Perm						0.05	0.04						
v/c Ratio	0.16	0.13		0.55	0.54	0.24	0.13	0.61				0.49	
Uniform Delay, d1	18.8	18.8		15.9	15.8	14.7	11.8	14.0				13.4	
Progression Factor	1.00	1.00		1.00	1.00	1.00	1.00	1.00				1.00	
Incremental Delay, d2	0.3	0.2		1.2	1.1	0.3	0.5	2.8				0.7	
Delay (s)	19.1	19.0		17.1	16.9	14.9	12.4	16.8				14.1	
Level of Service	B	B		B	B	B	B	B				B	
Approach Delay (s)		19.0			16.1			16.5				14.1	
Approach LOS		B			B			B				B	
Intersection Summary													
HCM Average Control Delay			15.8		HCM Level of Service						B		
HCM Volume to Capacity ratio			0.51										
Actuated Cycle Length (s)			47.0		Sum of lost time (s)						16.5		
Intersection Capacity Utilization			58.8%		ICU Level of Service						B		
Analysis Period (min)			15										

c Critical Lane Group

HCM Unsignalized Intersection Capacity Analysis

9: Nyberg St & Site Entrance 3

4/15/2013























Movement	EBL	EBT	WBT	WBR	SBL	SBR
Lane Configurations	↖		↕			↗
Volume (veh/h)	29	0	639	40	0	82
Sign Control		Free	Free		Stop	
Grade		0%	0%		0%	
Peak Hour Factor	0.88	0.88	0.88	0.88	0.88	0.88
Hourly flow rate (vph)	33	0	726	45	0	93
Pedestrians					5	
Lane Width (ft)					12.0	
Walking Speed (ft/s)					4.0	
Percent Blockage					0	
Right turn flare (veh)						
Median type		None	None			
Median storage (veh)						
Upstream signal (ft)		242				
pX, platoon unblocked						
vC, conflicting volume	777				820	391
vC1, stage 1 conf vol						
vC2, stage 2 conf vol						
vCu, unblocked vol	777				820	391
tC, single (s)	4.1				6.8	6.9
tC, 2 stage (s)						
tF (s)	2.2				3.5	3.3
p0 queue free %	96				100	85
cM capacity (veh/h)	845				304	611
Direction, Lane #	EB 1	WB 1	WB 2	SB 1		
Volume Total	33	484	288	93		
Volume Left	33	0	0	0		
Volume Right	0	0	45	93		
cSH	845	1700	1700	611		
Volume to Capacity	0.04	0.28	0.17	0.15		
Queue Length 95th (ft)	3	0	0	14		
Control Delay (s)	9.4	0.0	0.0	11.9		
Lane LOS	A			B		
Approach Delay (s)	9.4	0.0		11.9		
Approach LOS				B		
Intersection Summary						
Average Delay			1.6			
Intersection Capacity Utilization			30.7%		ICU Level of Service	A
Analysis Period (min)			15			

HCM Signalized Intersection Capacity Analysis

10: Tualatin Sherwood Rd & Site Entrance 4

4/15/2013

												
Movement	EBL	EBT	EBR	WBL	WBT	WBR	NBL	NBT	NBR	SBL	SBT	SBR
Lane Configurations												
Volume (vph)	32	1877	42	232	1691	72	36	10	236	182	24	44
Ideal Flow (vphpl)	1900	1900	1900	1900	1900	1900	1900	1900	1900	1900	1900	1900
Total Lost time (s)	4.5	6.0		4.5	6.0			5.0	4.5		5.0	5.0
Lane Util. Factor	1.00	*0.75		0.97	0.91			1.00	1.00		1.00	1.00
Frbp, ped/bikes	1.00	1.00		1.00	1.00			1.00	1.00		1.00	0.97
Flpb, ped/bikes	1.00	1.00		1.00	1.00			0.99	1.00		1.00	1.00
Frt	1.00	1.00		1.00	0.99			1.00	0.85		1.00	0.85
Flt Protected	0.95	1.00		0.95	1.00			0.96	1.00		0.96	1.00
Satd. Flow (prot)	1805	4099		3502	4956			1768	1599		1803	1565
Flt Permitted	0.95	1.00		0.95	1.00			0.54	1.00		0.72	1.00
Satd. Flow (perm)	1805	4099		3502	4956			1000	1599		1350	1565
Peak-hour factor, PHF	0.98	0.98	0.98	0.98	0.98	0.98	0.98	0.98	0.98	0.98	0.98	0.98
Adj. Flow (vph)	33	1915	43	237	1726	73	37	10	241	186	24	45
RTOR Reduction (vph)	0	1	0	0	3	0	0	0	0	0	0	37
Lane Group Flow (vph)	33	1957	0	237	1796	0	0	47	241	0	210	8
Confl. Peds. (#/hr)			2			8	15					15
Confl. Bikes (#/hr)					1			1		1		
Heavy Vehicles (%)	0%	4%	0%	0%	4%	0%	3%	0%	1%	1%	0%	0%
Turn Type	Prot			Prot			Perm		pm+ov	Perm		Perm
Protected Phases	5	2		1	6			8	1		4	
Permitted Phases							8		8	4		4
Actuated Green, G (s)	5.4	73.7		11.8	80.1			22.5	34.3		22.5	22.5
Effective Green, g (s)	5.9	74.2		12.3	80.6			23.0	35.3		23.0	23.0
Actuated g/C Ratio	0.05	0.59		0.10	0.64			0.18	0.28		0.18	0.18
Clearance Time (s)	5.0	6.5		5.0	6.5			5.5	5.0		5.5	5.5
Vehicle Extension (s)	2.5	4.0		2.5	4.0			2.5	2.5		2.5	2.5
Lane Grp Cap (vph)	85	2433		345	3196			184	452		248	288
v/s Ratio Prot	0.02	c0.48		c0.07	0.36				0.05			
v/s Ratio Perm								0.05	0.10		c0.16	0.01
v/c Ratio	0.39	0.80		0.69	0.56			0.26	0.53		0.85	0.03
Uniform Delay, d1	57.8	19.8		54.5	12.4			43.7	37.9		49.3	41.8
Progression Factor	0.76	0.49		0.99	0.98			1.00	1.00		1.00	1.00
Incremental Delay, d2	1.2	1.6		3.7	0.5			0.5	0.9		22.2	0.0
Delay (s)	45.1	11.3		57.7	12.7			44.2	38.8		71.5	41.9
Level of Service	D	B		E	B			D	D		E	D
Approach Delay (s)		11.8			17.9			39.7			66.3	
Approach LOS		B			B			D			E	
Intersection Summary												
HCM Average Control Delay			19.3			HCM Level of Service			B			
HCM Volume to Capacity ratio			0.80									
Actuated Cycle Length (s)			125.0			Sum of lost time (s)		15.5				
Intersection Capacity Utilization			81.1%			ICU Level of Service		D				
Analysis Period (min)			15									

c Critical Lane Group

HCM Unsignalized Intersection Capacity Analysis
 11: Tualatin Sherwood Rd & 75th Ave

4/15/2013

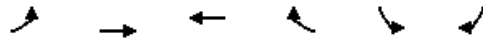













Movement	EBL	EBT	WBT	WBR	SBL	SBR
Lane Configurations		↑↑↑	↑↑↑			↗
Volume (veh/h)	0	2295	1995	35	0	4
Sign Control		Free	Free		Stop	
Grade		0%	0%		0%	
Peak Hour Factor	0.99	0.99	0.99	0.99	0.99	0.99
Hourly flow rate (vph)	0	2318	2015	35	0	4
Pedestrians					1	
Lane Width (ft)					12.0	
Walking Speed (ft/s)					4.0	
Percent Blockage					0	
Right turn flare (veh)						
Median type		None	None			
Median storage (veh)						
Upstream signal (ft)		373	260			
pX, platoon unblocked	0.81				0.75	0.81
vC, conflicting volume	2052				2807	690
vC1, stage 1 conf vol						
vC2, stage 2 conf vol						
vCu, unblocked vol	1465				477	0
tC, single (s)	4.1				6.8	7.0
tC, 2 stage (s)						
tF (s)	2.2				3.5	3.3
p0 queue free %	100				100	100
cM capacity (veh/h)	376				385	872

Direction, Lane #	EB 1	EB 2	EB 3	WB 1	WB 2	WB 3	SB 1
Volume Total	773	773	773	806	806	438	4
Volume Left	0	0	0	0	0	0	0
Volume Right	0	0	0	0	0	35	4
cSH	1700	1700	1700	1700	1700	1700	872
Volume to Capacity	0.45	0.45	0.45	0.47	0.47	0.26	0.00
Queue Length 95th (ft)	0	0	0	0	0	0	0
Control Delay (s)	0.0	0.0	0.0	0.0	0.0	0.0	9.1
Lane LOS							A
Approach Delay (s)	0.0			0.0			9.1
Approach LOS							A

Intersection Summary			
Average Delay		0.0	
Intersection Capacity Utilization	49.3%	ICU Level of Service	A
Analysis Period (min)	15		

HCM Signalized Intersection Capacity Analysis
 12: Tualatin Sherwood Rd & I-5 SB Ramps













4/15/2013

													
Movement	EBL	EBT	EBR	WBL	WBT	WBR	NBL	NBT	NBR	SBL	SBT	SBR	
Lane Configurations		↑↑↑	↑	↑	↑↑					↑	↑	↑↑	
Volume (vph)	0	1480	815	119	984	0	0	0	0	640	5	1045	
Ideal Flow (vphpl)	1900	1900	1900	1900	1900	1900	1900	1900	1900	1900	1900	1900	
Total Lost time (s)		5.5	5.5	5.5	5.5					5.5	5.5	5.5	
Lane Util. Factor		*0.75	1.00	1.00	0.95					0.95	0.95	0.88	
Frbp, ped/bikes		1.00	1.00	1.00	1.00					1.00	1.00	1.00	
Flpb, ped/bikes		1.00	1.00	1.00	1.00					1.00	1.00	1.00	
Frt		1.00	0.85	1.00	1.00					1.00	1.00	0.85	
Flt Protected		1.00	1.00	0.95	1.00					0.95	0.95	1.00	
Satd. Flow (prot)		4150	1568	1787	3471					1681	1682	2760	
Flt Permitted		1.00	1.00	0.95	1.00					0.95	0.95	1.00	
Satd. Flow (perm)		4150	1568	1787	3471					1681	1682	2760	
Peak-hour factor, PHF	0.99	0.99	0.99	0.99	0.99	0.99	0.99	0.99	0.99	0.99	0.99	0.99	
Adj. Flow (vph)	0	1495	823	120	994	0	0	0	0	646	5	1056	
RTOR Reduction (vph)	0	0	346	0	0	0	0	0	0	0	0	32	
Lane Group Flow (vph)	0	1495	477	120	994	0	0	0	0	323	328	1024	
Confl. Bikes (#/hr)		1			2								
Heavy Vehicles (%)	0%	3%	3%	1%	4%	0%	0%	0%	0%	2%	20%	3%	
Turn Type			Perm	Prot						Split		custom	
Protected Phases		2		1	6					4	4	4.5	
Permitted Phases			2										
Actuated Green, G (s)		58.8	58.8	11.0	53.8					37.2	37.2	59.2	
Effective Green, g (s)		59.3	59.3	11.5	54.3					37.7	37.7	59.7	
Actuated g/C Ratio		0.47	0.47	0.09	0.43					0.30	0.30	0.48	
Clearance Time (s)		6.0	6.0	6.0	6.0					6.0	6.0		
Vehicle Extension (s)		6.1	6.1	2.3	6.1					2.3	2.3		
Lane Grp Cap (vph)		1969	744	164	1508					507	507	1318	
v/s Ratio Prot		c0.36		0.07	c0.29					0.19	0.20	c0.37	
v/s Ratio Perm			0.30										
v/c Ratio		0.76	0.64	0.73	0.66					0.64	0.65	0.78	
Uniform Delay, d1		27.0	24.8	55.2	28.0					37.7	37.9	27.1	
Progression Factor		0.71	0.50	1.26	0.62					1.00	1.00	1.00	
Incremental Delay, d2		1.8	2.7	13.5	2.2					2.2	2.4	2.8	
Delay (s)		21.0	15.1	83.2	19.5					39.9	40.2	29.9	
Level of Service		C	B	F	B					D	D	C	
Approach Delay (s)		18.9			26.3			0.0			33.8		
Approach LOS		B			C			A			C		
Intersection Summary													
HCM Average Control Delay			25.4			HCM Level of Service				C			
HCM Volume to Capacity ratio			0.80										
Actuated Cycle Length (s)			125.0			Sum of lost time (s)				16.5			
Intersection Capacity Utilization			88.7%			ICU Level of Service				E			
Analysis Period (min)			15										
c Critical Lane Group													

HCM Signalized Intersection Capacity Analysis

13: Tualatin Sherwood Rd & I-5 NB Ramps





















4/15/2013

													
Movement	EBL	EBT	EBR	WBL	WBT	WBR	NBL	NBT	NBR	SBL	SBT	SBR	
Lane Configurations		↑↑	↑↑		↑↑	↑	↑	↑	↑				
Volume (vph)	0	1161	952	0	488	662	615	5	172	0	0	0	
Ideal Flow (vphpl)	1900	1900	1900	1900	1900	1900	1900	1900	1900	1900	1900	1900	
Total Lost time (s)		5.5	5.5		6.0	6.0	5.5	5.5	5.5				
Lane Util. Factor		0.95	0.88		0.95	1.00	0.95	0.95	1.00				
Frbp, ped/bikes		1.00	1.00		1.00	0.95	1.00	1.00	0.96				
Flpb, ped/bikes		1.00	1.00		1.00	1.00	1.00	1.00	1.00				
Frt		1.00	0.85		1.00	0.85	1.00	1.00	0.85				
Flt Protected		1.00	1.00		1.00	1.00	0.95	0.95	1.00				
Satd. Flow (prot)		3574	2760		3574	1502	1618	1620	1512				
Flt Permitted		1.00	1.00		1.00	1.00	0.95	0.95	1.00				
Satd. Flow (perm)		3574	2760		3574	1502	1618	1620	1512				
Peak-hour factor, PHF	0.95	0.95	0.95	0.95	0.95	0.95	0.95	0.95	0.95	0.95	0.95	0.95	
Adj. Flow (vph)	0	1222	1002	0	514	697	647	5	181	0	0	0	
RTOR Reduction (vph)	0	0	320	0	0	240	0	0	25	0	0	0	
Lane Group Flow (vph)	0	1222	682	0	514	457	323	329	156	0	0	0	
Confl. Peds. (#/hr)						16			17				
Confl. Bikes (#/hr)		1			5					1			
Heavy Vehicles (%)	0%	1%	3%	0%	1%	2%	6%	20%	2%	0%	0%	0%	
Turn Type			Perm			Perm	Split		Perm				
Protected Phases		2			6		8	8					
Permitted Phases			2			6			8				
Actuated Green, G (s)		82.0	82.0		81.5	81.5	31.0	31.0	31.0				
Effective Green, g (s)		82.5	82.5		82.0	82.0	31.5	31.5	31.5				
Actuated g/C Ratio		0.66	0.66		0.66	0.66	0.25	0.25	0.25				
Clearance Time (s)		6.0	6.0		6.5	6.5	6.0	6.0	6.0				
Vehicle Extension (s)		6.1	6.1		4.2	4.2	2.3	2.3	2.3				
Lane Grp Cap (vph)		2359	1822		2345	985	408	408	381				
v/s Ratio Prot		c0.34			0.14		0.20	c0.20					
v/s Ratio Perm			0.25			0.30			0.10				
v/c Ratio		0.52	0.37		0.22	0.46	0.79	0.81	0.41				
Uniform Delay, d1		11.0	9.6		8.6	10.6	43.7	43.9	39.0				
Progression Factor		0.45	0.24		1.00	1.00	1.00	1.00	1.00				
Incremental Delay, d2		0.6	0.4		0.2	1.6	9.6	10.7	0.4				
Delay (s)		5.5	2.8		8.9	12.2	53.3	54.6	39.4				
Level of Service		A	A		A	B	D	D	D				
Approach Delay (s)		4.3			10.8			50.8			0.0		
Approach LOS		A			B			D			A		
Intersection Summary													
HCM Average Control Delay			15.2				HCM Level of Service		B				
HCM Volume to Capacity ratio			0.60										
Actuated Cycle Length (s)			125.0				Sum of lost time (s)		11.0				
Intersection Capacity Utilization			69.3%				ICU Level of Service		C				
Analysis Period (min)			15										

c Critical Lane Group

HCM Signalized Intersection Capacity Analysis
 14: Tualatin Sherwood Rd & Nyberg Woods

4/15/2013

													
Movement	EBL	EBT	EBR	WBL	WBT	WBR	NBL	NBT	NBR	SBL	SBT	SBR	
Lane Configurations													
Volume (vph)	290	952	61	10	789	80	112	7	17	81	5	191	
Ideal Flow (vphpl)	1900	1900	1900	1900	1900	1900	1900	1900	1900	1900	1900	1900	
Total Lost time (s)	5.5	5.5		5.5	5.5			5.5	5.5		5.5	5.5	
Lane Util. Factor	0.97	0.95		1.00	0.95			1.00	1.00		1.00	1.00	
Frbp, ped/bikes	1.00	1.00		1.00	1.00			1.00	0.98		1.00	0.99	
Flpb, ped/bikes	1.00	1.00		1.00	1.00			1.00	1.00		1.00	1.00	
Frt	1.00	0.99		1.00	0.99			1.00	0.85		1.00	0.85	
Flt Protected	0.95	1.00		0.95	1.00			0.95	1.00		0.95	1.00	
Satd. Flow (prot)	3502	3502		1805	3522			1761	1590		1793	1592	
Flt Permitted	0.95	1.00		0.95	1.00			0.67	1.00		0.65	1.00	
Satd. Flow (perm)	3502	3502		1805	3522			1243	1590		1221	1592	
Peak-hour factor, PHF	0.96	0.96	0.96	0.96	0.96	0.96	0.96	0.96	0.96	0.96	0.96	0.96	
Adj. Flow (vph)	302	992	64	10	822	83	117	7	18	84	5	199	
RTOR Reduction (vph)	0	4	0	0	7	0	0	0	15	0	0	164	
Lane Group Flow (vph)	302	1052	0	10	898	0	0	124	3	0	89	35	
Confl. Peds. (#/hr)	9		2	2		9	3		4	4		3	
Confl. Bikes (#/hr)		1			3								
Heavy Vehicles (%)	0%	2%	2%	0%	1%	0%	3%	0%	0%	1%	0%	0%	
Turn Type	Prot			Prot			Perm		Perm	Perm		Perm	
Protected Phases	5	2		1	6			8				4	
Permitted Phases							8		8	4		4	
Actuated Green, G (s)	8.9	32.0		0.7	23.8			10.2	10.2			10.2	
Effective Green, g (s)	9.4	32.5		1.2	24.3			10.7	10.7			10.7	
Actuated g/C Ratio	0.15	0.53		0.02	0.40			0.18	0.18			0.18	
Clearance Time (s)	6.0	6.0		6.0	6.0			6.0	6.0			6.0	
Vehicle Extension (s)	2.3	2.5		2.4	2.5			2.4	2.4			2.3	
Lane Grp Cap (vph)	541	1869		36	1405			218	279			215	
v/s Ratio Prot	c0.09	c0.30		0.01	c0.25								
v/s Ratio Perm								c0.10	0.00			0.07	
v/c Ratio	0.56	0.56		0.28	0.64			0.57	0.01			0.41	
Uniform Delay, d1	23.8	9.5		29.4	14.8			23.0	20.7			22.3	
Progression Factor	1.00	1.00		1.00	1.00			1.00	1.00			1.00	
Incremental Delay, d2	0.9	0.3		2.7	0.8			2.6	0.0			0.8	
Delay (s)	24.7	9.8		32.2	15.6			25.6	20.7			23.1	
Level of Service	C	A		C	B			C	C			C	
Approach Delay (s)		13.1			15.8			25.0				21.8	
Approach LOS		B			B			C				C	





















Intersection Summary

HCM Average Control Delay	15.6	HCM Level of Service	B
HCM Volume to Capacity ratio	0.70		
Actuated Cycle Length (s)	60.9	Sum of lost time (s)	22.0
Intersection Capacity Utilization	60.3%	ICU Level of Service	B
Analysis Period (min)	15		

c Critical Lane Group



























HCM Signalized Intersection Capacity Analysis
 15: SW Nyberg St & SW Nyberg St

4/15/2013

												
Movement	EBL	EBT	EBR	WBL	WBT	WBR	NBL	NBT	NBR	SBL	SBT	SBR
Lane Configurations												
Volume (vph)	217	900	26	24	737	16	17	9	45	5	7	135
Ideal Flow (vphpl)	1900	1900	1900	1900	1900	1900	1900	1900	1900	1900	1900	1900
Total Lost time (s)	4.8	4.8		4.8	4.8			5.6	5.6		5.3	4.8
Lane Util. Factor	1.00	1.00		1.00	0.95			1.00	1.00		1.00	1.00
Frpb, ped/bikes	1.00	1.00		1.00	1.00			1.00	1.00		1.00	1.00
Flpb, ped/bikes	1.00	1.00		1.00	1.00			1.00	1.00		1.00	1.00
Frt	1.00	1.00		1.00	1.00			1.00	0.85		1.00	0.85
Flt Protected	0.95	1.00		0.95	1.00			0.97	1.00		0.98	1.00
Satd. Flow (prot)	1805	1867		1805	3563			1762	1583		1861	1607
Flt Permitted	0.95	1.00		0.95	1.00			0.97	1.00		0.69	1.00
Satd. Flow (perm)	1805	1867		1805	3563			1762	1583		1313	1607
Peak-hour factor, PHF	0.94	0.94	0.94	0.94	0.94	0.94	0.94	0.94	0.94	0.94	0.94	0.94
Adj. Flow (vph)	231	957	28	26	784	17	18	10	48	5	7	144
RTOR Reduction (vph)	0	0	0	0	1	0	0	0	45	0	0	115
Lane Group Flow (vph)	231	985	0	26	800	0	0	28	3	0	12	29
Confl. Peds. (#/hr)			30	30			6					6
Heavy Vehicles (%)	0%	1%	5%	0%	1%	1%	7%	0%	2%	0%	0%	0%
Turn Type	Prot			Prot			Split		Perm	Perm		pm+ov
Protected Phases	5	2		1	6		8	8			4	5
Permitted Phases									8	4		4
Actuated Green, G (s)	11.6	48.9		1.7	39.0			4.1	4.1		3.6	15.2
Effective Green, g (s)	12.1	49.4		2.2	39.5			4.6	4.6		4.1	16.2
Actuated g/C Ratio	0.15	0.61		0.03	0.49			0.06	0.06		0.05	0.20
Clearance Time (s)	5.3	5.3		5.3	5.3			6.1	6.1		5.8	5.3
Vehicle Extension (s)	2.5	3.0		1.0	3.0			1.0	1.0		2.0	2.5
Lane Grp Cap (vph)	270	1141		49	1742			100	90		67	322
v/s Ratio Prot	c0.13	c0.53		0.01	0.22			c0.02				0.01
v/s Ratio Perm									0.00		c0.01	0.00
v/c Ratio	0.86	0.86		0.53	0.46			0.28	0.03		0.18	0.09
Uniform Delay, d1	33.5	12.9		38.8	13.6			36.5	36.0		36.7	26.3
Progression Factor	1.00	1.00		1.00	1.00			1.00	1.00		1.00	1.00
Incremental Delay, d2	22.1	6.9		5.4	0.2			0.6	0.1		0.5	0.1
Delay (s)	55.6	19.8		44.2	13.8			37.1	36.0		37.2	26.4
Level of Service	E	B		D	B			D	D		D	C
Approach Delay (s)		26.6			14.8			36.4			27.2	
Approach LOS		C			B			D			C	
Intersection Summary												
HCM Average Control Delay			22.7			HCM Level of Service				C		
HCM Volume to Capacity ratio			0.75									
Actuated Cycle Length (s)			80.8			Sum of lost time (s)		15.7				
Intersection Capacity Utilization			73.9%			ICU Level of Service			D			
Analysis Period (min)			15									
c Critical Lane Group												

























HCM Signalized Intersection Capacity Analysis
 16: SW Tualatin Sherwood Rd & SW Boones Ferry Rd

4/15/2013

												
Movement	EBL	EBT	EBR	WBL	WBT	WBR	NBL	NBT	NBR	SBL	SBT	SBR
Lane Configurations		 		 	 				 		 	
Volume (vph)	100	984	134	217	1051	54	166	260	154	288	335	129
Ideal Flow (vphpl)	1900	1900	1900	1900	1900	1900	1900	1900	1900	1900	1900	1900
Total Lost time (s)	4.5	5.5		4.5	5.5		4.5	5.0	4.5	4.5	5.0	
Lane Util. Factor	1.00	0.95		0.97	0.95		1.00	1.00	1.00	1.00	0.95	
Frbp, ped/bikes	1.00	1.00		1.00	1.00		1.00	1.00	0.98	1.00	0.99	
Flpb, ped/bikes	1.00	1.00		1.00	1.00		1.00	1.00	1.00	1.00	1.00	
Frt	1.00	0.98		1.00	0.99		1.00	1.00	0.85	1.00	0.96	
Flt Protected	0.95	1.00		0.95	1.00		0.95	1.00	1.00	0.95	1.00	
Satd. Flow (prot)	1703	3319		3502	3338		1732	1810	1542	1761	3313	
Flt Permitted	0.95	1.00		0.95	1.00		0.42	1.00	1.00	0.60	1.00	
Satd. Flow (perm)	1703	3319		3502	3338		760	1810	1542	1107	3313	
Peak-hour factor, PHF	0.99	0.99	0.99	0.99	0.99	0.99	0.99	0.99	0.99	0.99	0.99	0.99
Adj. Flow (vph)	101	994	135	219	1062	55	168	263	156	291	338	130
RTOR Reduction (vph)	0	8	0	0	3	0	0	0	59	0	35	0
Lane Group Flow (vph)	101	1121	0	219	1114	0	168	263	97	291	433	0
Confl. Peds. (#/hr)			7			15	7		8	8		7
Heavy Vehicles (%)	6%	7%	3%	0%	7%	6%	4%	5%	3%	2%	4%	3%
Turn Type	Prot			Prot			pm+pt		pm+ov		pm+pt	
Protected Phases	5	2		1	6		3	8	1	7	4	
Permitted Phases							8		8	4		
Actuated Green, G (s)	10.0	56.7		9.4	56.1		20.9	20.9	30.3	26.6	26.1	
Effective Green, g (s)	10.5	57.2		9.9	56.6		21.4	21.4	31.3	27.1	26.6	
Actuated g/C Ratio	0.08	0.46		0.08	0.45		0.17	0.17	0.25	0.22	0.21	
Clearance Time (s)	5.0	6.0		5.0	6.0		5.0	5.5	5.0	5.0	5.5	
Vehicle Extension (s)	2.0	3.5		2.0	3.5		2.0	2.0	2.0	2.0	2.0	
Lane Grp Cap (vph)	143	1519		277	1511		222	310	386	329	705	
v/s Ratio Prot	0.06	c0.34		0.06	c0.33		0.07	c0.15	0.02	c0.12	0.13	
v/s Ratio Perm							0.06		0.04	c0.07		
v/c Ratio	0.71	0.74		0.79	0.74		0.76	0.85	0.25	0.88	0.61	
Uniform Delay, d1	55.7	27.8		56.5	28.1		47.7	50.2	37.5	46.2	44.6	
Progression Factor	1.00	1.00		0.99	0.45		1.00	1.00	1.00	1.00	1.00	
Incremental Delay, d2	12.2	3.3		9.0	2.1		12.3	18.3	0.1	22.8	1.1	
Delay (s)	67.9	31.0		64.9	14.7		59.9	68.5	37.6	69.0	45.7	
Level of Service	E	C		E	B		E	E	D	E	D	
Approach Delay (s)		34.1			22.9			57.8			54.6	
Approach LOS		C			C			E			D	
Intersection Summary												
HCM Average Control Delay			37.8			HCM Level of Service				D		
HCM Volume to Capacity ratio			0.82									
Actuated Cycle Length (s)			125.0			Sum of lost time (s)			20.5			
Intersection Capacity Utilization			85.3%			ICU Level of Service			E			
Analysis Period (min)			15									
c Critical Lane Group												



















HCM Signalized Intersection Capacity Analysis
 17: Tualatin Sherwood Rd & Martinazzi Ave

4/15/2013

												
Movement	EBL	EBT	EBR	WBL	WBT	WBR	NBL	NBT	NBR	SBL	SBT	SBR
Lane Configurations		 			 				 		 	
Volume (vph)	50	1440	81	0	1091	1	92	293	314	188	643	85
Ideal Flow (vphpl)	1900	1900	1900	1900	1900	1900	1900	1900	1900	1900	1900	1900
Total Lost time (s)	4.5	5.5			5.5		4.5	5.5	5.5	4.5	5.5	
Lane Util. Factor	1.00	*0.95			0.95		1.00	1.00	1.00	1.00	0.95	
Frpb, ped/bikes	1.00	1.00			1.00		1.00	1.00	0.98	1.00	1.00	
Flpb, ped/bikes	1.00	1.00			1.00		1.00	1.00	1.00	1.00	1.00	
Fr t	1.00	0.99			1.00		1.00	1.00	0.85	1.00	0.98	
Fl t Protected	0.95	1.00			1.00		0.95	1.00	1.00	0.95	1.00	
Satd. Flow (prot)	1719	3447			3438		1770	1863	1574	1787	3498	
Fl t Permitted	0.95	1.00			1.00		0.95	1.00	1.00	0.95	1.00	
Satd. Flow (perm)	1719	3447			3438		1770	1863	1574	1787	3498	
Peak-hour factor, PHF	0.94	0.94	0.94	0.94	0.94	0.94	0.94	0.94	0.94	0.94	0.94	0.94
Adj. Flow (vph)	53	1532	86	0	1161	1	98	312	334	200	684	90
RTOR Reduction (vph)	0	3	0	0	0	0	0	0	50	0	8	0
Lane Group Flow (vph)	53	1615	0	0	1162	0	98	312	284	200	766	0
Confl. Peds. (#/hr)			4				2		3			16
Heavy Vehicles (%)	5%	4%	0%	0%	5%	0%	2%	2%	1%	1%	1%	1%
Turn Type	Prot						Prot		Perm	Prot		
Protected Phases	5	2			6		3	8		7	4	
Permitted Phases									8			
Actuated Green, G (s)	8.0	67.7			54.7		9.0	23.5	23.5	16.8	31.3	
Effective Green, g (s)	8.5	68.2			55.2		9.5	24.0	24.0	17.3	31.8	
Actuated g/C Ratio	0.07	0.55			0.44		0.08	0.19	0.19	0.14	0.25	
Clearance Time (s)	5.0	6.0			6.0		5.0	6.0	6.0	5.0	6.0	
Vehicle Extension (s)	2.0	3.5			3.5		3.0	2.0	2.0	3.0	2.0	
Lane Grp Cap (vph)	117	1881			1518		135	358	302	247	890	
v/s Ratio Prot	0.03	c0.47			0.34		0.06	0.17		0.11	c0.22	
v/s Ratio Perm									c0.18			
v/c Ratio	0.45	0.86			0.77		0.73	0.87	0.94	0.81	0.86	
Uniform Delay, d1	56.0	24.3			29.4		56.5	49.0	49.8	52.3	44.5	
Progression Factor	0.84	1.11			0.64		1.00	1.00	1.00	1.00	1.00	
Incremental Delay, d2	0.8	4.3			3.3		17.6	19.5	35.8	17.5	8.2	
Delay (s)	47.6	31.1			22.0		74.0	68.5	85.6	69.8	52.7	
Level of Service	D	C			C		E	E	F	E	D	
Approach Delay (s)		31.7			22.0			76.9			56.2	
Approach LOS		C			C			E			E	
Intersection Summary												
HCM Average Control Delay			41.8				HCM Level of Service			D		
HCM Volume to Capacity ratio			0.85									
Actuated Cycle Length (s)			125.0				Sum of lost time (s)		11.0			
Intersection Capacity Utilization			85.9%				ICU Level of Service		E			
Analysis Period (min)			15									
c Critical Lane Group												





















HCM Signalized Intersection Capacity Analysis
18: SW Borland Rd & SW 65th Ave

4/15/2013

												
Movement	EBL	EBT	EBR	WBL	WBT	WBR	NBL	NBT	NBR	SBL	SBT	SBR
Lane Configurations												
Volume (vph)	23	23	10	233	0	227	2	324	349	411	460	10
Ideal Flow (vphpl)	1900	1900	1900	1900	1900	1900	1900	1900	1900	1900	1900	1900
Total Lost time (s)		5.6			5.3	5.6	4.8	4.8		4.8	4.8	
Lane Util. Factor		1.00			1.00	1.00	1.00	1.00		1.00	1.00	
Frbp, ped/bikes		0.98			1.00	1.00	1.00	0.98		1.00	1.00	
Flpb, ped/bikes		1.00			1.00	1.00	0.99	1.00		1.00	1.00	
Frt		0.97			1.00	0.85	1.00	0.92		1.00	1.00	
Flt Protected		0.98			0.95	1.00	0.95	1.00		0.95	1.00	
Satd. Flow (prot)		1775			1787	1583	1794	1686		1805	1838	
Flt Permitted		0.98			0.95	1.00	0.48	1.00		0.10	1.00	
Satd. Flow (perm)		1775			1787	1583	911	1686		189	1838	
Peak-hour factor, PHF	0.95	0.95	0.95	0.95	0.95	0.95	0.95	0.95	0.95	0.95	0.95	0.95
Adj. Flow (vph)	24	24	11	245	0	239	2	341	367	433	484	11
RTOR Reduction (vph)	0	6	0	0	0	226	0	25	0	0	0	0
Lane Group Flow (vph)	0	53	0	0	245	13	2	683	0	433	495	0
Confl. Peds. (#/hr)			11	11			7		7	7		7
Heavy Vehicles (%)	0%	0%	0%	1%	0%	2%	0%	1%	2%	0%	3%	0%
Turn Type	Split			Split		custom	pm+pt			pm+pt		
Protected Phases	8	8		4	4		1	6		5	2	
Permitted Phases						8	6			2		
Actuated Green, G (s)		7.4			20.0	7.4	64.4	63.4		98.7	92.4	
Effective Green, g (s)		7.9			20.5	7.9	65.4	63.9		99.2	92.9	
Actuated g/C Ratio		0.06			0.14	0.06	0.46	0.45		0.69	0.65	
Clearance Time (s)		6.1			5.8	6.1	5.3	5.3		5.3	5.3	
Vehicle Extension (s)		1.0			2.0	1.0	1.0	3.0		2.5	0.2	
Lane Grp Cap (vph)		98			256	87	425	752		475	1192	
v/s Ratio Prot		c0.03			c0.14		0.00	0.41		c0.19	0.27	
v/s Ratio Perm						0.01	0.00			c0.44		
v/c Ratio		0.54			0.96	0.15	0.00	0.91		0.91	0.41	
Uniform Delay, d1		65.9			61.0	64.5	21.2	37.0		41.0	12.1	
Progression Factor		1.00			1.00	1.00	1.00	1.00		1.00	1.00	
Incremental Delay, d2		3.3			43.7	0.3	0.0	14.7		21.7	0.1	
Delay (s)		69.2			104.7	64.8	21.2	51.7		62.6	12.2	
Level of Service		E			F	E	C	D		E	B	
Approach Delay (s)		69.2			85.0			51.6			35.7	
Approach LOS		E			F			D			D	
Intersection Summary												
HCM Average Control Delay			52.7								HCM Level of Service	D
HCM Volume to Capacity ratio			0.88									
Actuated Cycle Length (s)			143.3								Sum of lost time (s)	15.7
Intersection Capacity Utilization			93.6%								ICU Level of Service	F
Analysis Period (min)			15									
c Critical Lane Group												

HCM Signalized Intersection Capacity Analysis
 19: SW Sagert St & SW Boones Ferry Rd

4/15/2013

													
Movement	EBL	EBT	EBR	WBL	WBT	WBR	NBL	NBT	NBR	SBL	SBT	SBR	
Lane Configurations													
Volume (vph)	41	104	13	161	109	62	16	462	212	63	545	73	
Ideal Flow (vphpl)	1900	1900	1900	1900	1900	1900	1900	1900	1900	1900	1900	1900	
Total Lost time (s)	3.5	3.5		3.5	3.5		3.5	4.0		3.5	4.0		
Lane Util. Factor	1.00	1.00		1.00	1.00		1.00	1.00		1.00	1.00		
Frbp, ped/bikes	1.00	1.00		1.00	0.99		1.00	0.99		1.00	1.00		
Flpb, ped/bikes	1.00	1.00		1.00	1.00		1.00	1.00		1.00	1.00		
Frt	1.00	0.98		1.00	0.95		1.00	0.95		1.00	0.98		
Flt Protected	0.95	1.00		0.95	1.00		0.95	1.00		0.95	1.00		
Satd. Flow (prot)	1797	1829		1745	1754		1804	1753		1805	1843		
Flt Permitted	0.64	1.00		0.44	1.00		0.26	1.00		0.17	1.00		
Satd. Flow (perm)	1212	1829		806	1754		490	1753		327	1843		
Peak-hour factor, PHF	0.92	0.92	0.92	0.92	0.92	0.92	0.92	0.92	0.92	0.92	0.92	0.92	
Adj. Flow (vph)	45	113	14	175	118	67	17	502	230	68	592	79	
RTOR Reduction (vph)	0	4	0	0	18	0	0	11	0	0	3	0	
Lane Group Flow (vph)	45	123	0	175	167	0	17	721	0	68	668	0	
Confl. Peds. (#/hr)	5		7	7		5	9		5	5		9	
Heavy Vehicles (%)	0%	2%	0%	3%	1%	2%	0%	3%	1%	0%	1%	0%	
Turn Type	pm+pt		pm+pt				pm+pt			pm+pt			
Protected Phases	7	4		3	8		5	2		1	6		
Permitted Phases	4			8			2			6			
Actuated Green, G (s)	15.2	12.2		25.8	18.8		47.0	45.5		51.6	47.8		
Effective Green, g (s)	16.2	12.7		26.3	19.3		48.0	46.0		52.6	48.3		
Actuated g/C Ratio	0.18	0.14		0.30	0.22		0.55	0.53		0.60	0.55		
Clearance Time (s)	4.0	4.0		4.0	4.0		4.0	4.5		4.0	4.5		
Vehicle Extension (s)	2.2	2.2		2.2	2.2		2.2	5.0		2.2	5.0		
Lane Grp Cap (vph)	248	265		350	386		298	921		269	1016		
v/s Ratio Prot	0.01	0.07		c0.06	0.10		0.00	c0.41		c0.01	0.36		
v/s Ratio Perm	0.03			c0.09			0.03			0.14			
v/c Ratio	0.18	0.46		0.50	0.43		0.06	0.78		0.25	0.66		
Uniform Delay, d1	29.8	34.3		24.1	29.4		10.7	16.8		11.8	13.8		
Progression Factor	1.00	1.00		1.00	1.00		1.00	1.00		1.00	1.00		
Incremental Delay, d2	0.2	0.7		0.6	0.4		0.0	5.1		0.3	2.1		
Delay (s)	30.0	35.0		24.6	29.8		10.8	21.8		12.0	15.9		
Level of Service	C	C		C	C		B	C		B	B		
Approach Delay (s)		33.7			27.3			21.6			15.6		
Approach LOS		C			C			C			B		
Intersection Summary													
HCM Average Control Delay			21.4			HCM Level of Service				C			
HCM Volume to Capacity ratio			0.68										
Actuated Cycle Length (s)			87.6			Sum of lost time (s)			14.5				
Intersection Capacity Utilization			72.2%			ICU Level of Service				C			
Analysis Period (min)			15										
c Critical Lane Group													

Phone:
E-Mail:

Fax:

ALL-WAY STOP CONTROL (AWSC) ANALYSIS

Analyst:
Agency/Co.:
Date Performed: 4/16/2013
Analysis Time Period: Weekday PM
Intersection: Sagert/Martinazzi
Jurisdiction:
Units: U. S. Customary
Analysis Year: Existing
Project ID:
East/West Street: Sagert
North/South Street: Martinazzi

Worksheet 2 - Volume Adjustments and Site Characteristics

	Eastbound			Westbound			Northbound			Southbound		
	L	T	R	L	T	R	L	T	R	L	T	R
Volume	114	226	12	87	189	159	2	175	74	201	287	232
% Thrus Left Lane												

	Eastbound		Westbound		Northbound		Southbound	
	L1	L2	L1	L2	L1	L2	L1	L2
Configuration	L	TR	L	TR	L	TR	L	TR
PHF	0.90	0.90	0.90	0.90	0.90	0.90	0.90	0.90
Flow Rate	126	264	96	386	2	276	223	575
% Heavy Veh	1	1	1	1	1	1	1	1
No. Lanes		2		2		2		2
Opposing-Lanes		2		2		2		2
Conflicting-lanes		2		2		2		2
Geometry group		5		5		5		5
Duration, T	0.25 hrs.							

Worksheet 3 - Saturation Headway Adjustment Worksheet

	Eastbound		Westbound		Northbound		Southbound	
	L1	L2	L1	L2	L1	L2	L1	L2
Flow Rates:								
Total in Lane	126	264	96	386	2	276	223	575
Left-Turn	126	0	96	0	2	0	223	0
Right-Turn	0	13	0	176	0	82	0	257
Prop. Left-Turns	1.0	0.0	1.0	0.0	1.0	0.0	1.0	0.0
Prop. Right-Turns	0.0	0.0	0.0	0.5	0.0	0.3	0.0	0.4
Prop. Heavy Vehicle	0.0	0.0	0.0	0.0	0.0	0.0	0.0	0.0
Geometry Group		5		5		5		5
Adjustments Exhibit 17-33:								
hLT-adj		0.5		0.5		0.5		0.5

hRT-adj	-0.7	-0.7	-0.7	-0.7
hHV-adj	1.7	1.7	1.7	1.7
hadj, computed	0.5	-0.0	0.5	-0.3

Worksheet 4 - Departure Headway and Service Time

	Eastbound		Westbound		Northbound		Southbound	
	L1	L2	L1	L2	L1	L2	L1	L2
Flow rate	126	264	96	386	2	276	223	575
hd, initial value	3.20	3.20	3.20	3.20	3.20	3.20	3.20	3.20
x, initial	0.11	0.23	0.09	0.34	0.00	0.25	0.20	0.51
hd, final value	9.14	8.60	8.93	8.11	9.32	8.61	8.67	7.86
x, final value	0.32	0.63	0.24	0.87	0.01	0.66	0.54	1.26
Move-up time, m		2.3		2.3		2.3		2.3
Service Time	6.8	6.3	6.6	5.8	7.0	6.3	6.4	5.6

Worksheet 5 - Capacity and Level of Service

	Eastbound		Westbound		Northbound		Southbound	
	L1	L2	L1	L2	L1	L2	L1	L2
Flow Rate	126	264	96	386	2	276	223	575
Service Time	6.8	6.3	6.6	5.8	7.0	6.3	6.4	5.6
Utilization, x	0.32	0.63	0.24	0.87	0.01	0.66	0.54	1.26
Dep. headway, hd	9.14	8.60	8.93	8.11	9.32	8.61	8.67	7.86
Capacity	376	413	346	442	252	411	413	575
Delay	16.08	24.90	14.39	44.90	12.07	26.51	20.99	155.89
LOS	C	C	B	E	B	D	C	F
Approach:								
Delay		22.05		38.83		26.41		118.19
LOS		C		E		D		F
Intersection Delay	66.21							
					Intersection LOS	F		

Phone:
E-Mail:

Fax:

ALL-WAY STOP CONTROL (AWSC) ANALYSIS

Analyst:
Agency/Co.:
Date Performed: 4/16/2013
Analysis Time Period: Weekday PM
Intersection: Sagert/65th
Jurisdiction:
Units: U. S. Customary
Analysis Year: Existing
Project ID:
East/West Street: Sagert
North/South Street: 65th

Worksheet 2 - Volume Adjustments and Site Characteristics

	Eastbound			Westbound			Northbound			Southbound		
	L	T	R	L	T	R	L	T	R	L	T	R
Volume	389	2	131	2	7	6	56	280	3	3	326	
% Thrus Left Lane												

	Eastbound		Westbound		Northbound		Southbound	
	L1	L2	L1	L2	L1	L2	L1	L2
Configuration	L	TR	L	TR	L	TR	L	TR
PHF	0.90	0.90	0.90	0.90	0.90	0.90	0.90	0.90
Flow Rate	432	147	2	13	62	314	3	790
% Heavy Veh	1	1	0	0	1	2	1	2
No. Lanes		2		2		2		2
Opposing-Lanes		2		2		2		2
Conflicting-lanes		2		2		2		2
Geometry group		5		5		5		5
Duration, T	0.25 hrs.							

Worksheet 3 - Saturation Headway Adjustment Worksheet

	Eastbound		Westbound		Northbound		Southbound	
	L1	L2	L1	L2	L1	L2	L1	L2
Flow Rates:								
Total in Lane	432	147	2	13	62	314	3	790
Left-Turn	432	0	2	0	62	0	3	0
Right-Turn	0	145	0	6	0	3	0	428
Prop. Left-Turns	1.0	0.0	1.0	0.0	1.0	0.0	1.0	0.0
Prop. Right-Turns	0.0	1.0	0.0	0.5	0.0	0.0	0.0	0.5
Prop. Heavy Vehicle	0.0	0.0	0.0	0.0	0.0	0.0	0.0	0.0
Geometry Group		5		5		5		5
Adjustments Exhibit 17-33:								
hLT-adj		0.5		0.5		0.5		0.5

hRT-adj	-0.7	-0.7	-0.7	-0.7
hHV-adj	1.7	1.7	1.7	1.7
hadj, computed	0.5	-0.7	0.5	-0.3

Worksheet 4 - Departure Headway and Service Time

	Eastbound		Westbound		Northbound		Southbound	
	L1	L2	L1	L2	L1	L2	L1	L2
Flow rate	432	147	2	13	62	314	3	790
hd, initial value	3.20	3.20	3.20	3.20	3.20	3.20	3.20	3.20
x, initial	0.38	0.13	0.00	0.01	0.06	0.28	0.00	0.70
hd, final value	7.70	6.51	9.15	8.33	7.93	7.44	7.69	6.83
x, final value	0.92	0.27	0.01	0.03	0.14	0.65	0.01	1.50
Move-up time, m		2.3		2.3		2.3		2.3
Service Time	5.4	4.2	6.8	6.0	5.6	5.1	5.4	4.5

Worksheet 5 - Capacity and Level of Service

	Eastbound		Westbound		Northbound		Southbound	
	L1	L2	L1	L2	L1	L2	L1	L2
Flow Rate	432	147	2	13	62	314	3	790
Service Time	5.4	4.2	6.8	6.0	5.6	5.1	5.4	4.5
Utilization, x	0.92	0.27	0.01	0.03	0.14	0.65	0.01	1.50
Dep. headway, hd	7.70	6.51	9.15	8.33	7.93	7.44	7.69	6.83
Capacity	467	397	252	263	312	479	253	790
Delay	52.42	11.55	11.90	11.28	11.89	22.90	10.44	252.56
LOS	F	B	B	B	B	C	B	F
Approach:								
Delay		42.04		11.37		21.08		251.65
LOS		E		B		C		F
Intersection Delay	131.59							

HCM Signalized Intersection Capacity Analysis

3: SW Boones Ferry Road & SW Martinazzi Ave

4/17/2013

	→	↘	↙	←	↖	↗
Movement	EBT	EBR	WBL	WBT	NBL	NBR
Lane Configurations	↑	↗	↘	↑	↘	↗
Volume (vph)	405	121	250	416	180	295
Ideal Flow (vphpl)	1900	1900	1900	1900	1900	1900
Total Lost time (s)	4.5	4.5	4.5	4.5	4.5	4.5
Lane Util. Factor	1.00	1.00	1.00	1.00	1.00	1.00
Frpb, ped/bikes	1.00	1.00	1.00	1.00	1.00	0.99
Flpb, ped/bikes	1.00	1.00	1.00	1.00	1.00	1.00
Fr _t	1.00	0.85	1.00	1.00	1.00	0.85
Fl _t Protected	1.00	1.00	0.95	1.00	0.95	1.00
Satd. Flow (prot)	1863	1599	1787	1845	1770	1582
Fl _t Permitted	1.00	1.00	0.95	1.00	0.95	1.00
Satd. Flow (perm)	1863	1599	1787	1845	1770	1582
Peak-hour factor, PHF	0.95	0.95	0.95	0.95	0.95	0.95
Adj. Flow (vph)	426	127	263	438	189	311
RTOR Reduction (vph)	0	88	0	0	0	97
Lane Group Flow (vph)	426	39	263	438	189	214
Confl. Peds. (#/hr)		11	11		1	3
Confl. Bikes (#/hr)	4		2	10	1	
Heavy Vehicles (%)	2%	1%	1%	3%	2%	1%
Turn Type		Prot	Prot			pm+ov
Protected Phases	2	2	1	6	8	1
Permitted Phases					8	8
Actuated Green, G (s)	16.7	16.7	13.3	35.0	10.8	24.1
Effective Green, g (s)	17.2	17.2	13.8	35.5	11.3	25.1
Actuated g/C Ratio	0.31	0.31	0.25	0.64	0.20	0.45
Clearance Time (s)	5.0	5.0	5.0	5.0	5.0	5.0
Vehicle Extension (s)	3.0	3.0	3.0	3.0	3.0	3.0
Lane Grp Cap (vph)	574	493	442	1174	358	839
v/s Ratio Prot	c0.23	0.02	c0.15	0.24	c0.11	0.06
v/s Ratio Perm						0.07
v/c Ratio	0.74	0.08	0.60	0.37	0.53	0.25
Uniform Delay, d ₁	17.3	13.7	18.5	4.8	19.9	9.5
Progression Factor	1.00	1.00	1.00	1.00	1.00	1.00
Incremental Delay, d ₂	5.2	0.1	2.2	0.2	1.4	0.2
Delay (s)	22.5	13.8	20.7	5.0	21.3	9.7
Level of Service	C	B	C	A	C	A
Approach Delay (s)	20.5			10.9	14.1	
Approach LOS	C			B	B	

Intersection Summary











HCM Average Control Delay	14.8	HCM Level of Service	B
HCM Volume to Capacity ratio	0.64		
Actuated Cycle Length (s)	55.8	Sum of lost time (s)	13.5
Intersection Capacity Utilization	57.1%	ICU Level of Service	B
Analysis Period (min)	15		

c Critical Lane Group

HCM Unsignalized Intersection Capacity Analysis

4: Site Entrance 1 & Martinazzi Ave

4/17/2013

						
Movement	WBL	WBR	NBT	NBR	SBL	SBT
Lane Configurations						
Volume (veh/h)	46	80	396	60	110	261
Sign Control	Stop		Free			Free
Grade	0%		0%			0%
Peak Hour Factor	0.92	0.92	0.92	0.92	0.92	0.92
Hourly flow rate (vph)	50	87	430	65	120	284
Pedestrians	13					6
Lane Width (ft)	12.0					12.0
Walking Speed (ft/s)	4.0					4.0
Percent Blockage	1					1
Right turn flare (veh)						
Median type			None			TWLTL
Median storage (veh)						2
Upstream signal (ft)			428			355
pX, platoon unblocked	0.98	0.98			0.98	
vC, conflicting volume	999	482			509	
vC1, stage 1 conf vol	476					
vC2, stage 2 conf vol	523					
vCu, unblocked vol	988	460			488	
tC, single (s)	6.4	6.2			4.1	
tC, 2 stage (s)	5.4					
tF (s)	3.5	3.3			2.2	
p0 queue free %	89	85			89	
cM capacity (veh/h)	447	583			1052	
Direction, Lane #	WB 1	WB 2	NB 1	SB 1	SB 2	
Volume Total	50	87	496	120	284	
Volume Left	50	0	0	120	0	
Volume Right	0	87	65	0	0	
cSH	447	583	1700	1052	1700	
Volume to Capacity	0.11	0.15	0.29	0.11	0.17	
Queue Length 95th (ft)	10	14	0	10	0	
Control Delay (s)	14.1	12.3	0.0	8.9	0.0	
Lane LOS	B	B		A		
Approach Delay (s)	12.9		0.0	2.6		
Approach LOS	B					
Intersection Summary						
Average Delay			2.7			
Intersection Capacity Utilization			45.9%		ICU Level of Service	A
Analysis Period (min)			15			

HCM Unsignalized Intersection Capacity Analysis

5: Seneca St & Martinazzi Ave

4/17/2013



Movement	EBL	EBR	NBL	NBT	SBT	SBR
Lane Configurations						
Volume (veh/h)	37	45	81	419	263	44
Sign Control	Stop			Free	Free	
Grade	0%			0%	0%	
Peak Hour Factor	0.91	0.91	0.91	0.91	0.91	0.91
Hourly flow rate (vph)	41	49	89	460	289	48
Pedestrians	1			4	10	
Lane Width (ft)	12.0			12.0	12.0	
Walking Speed (ft/s)	4.0			4.0	4.0	
Percent Blockage	0			0	1	
Right turn flare (veh)						
Median type				None	None	
Median storage (veh)						
Upstream signal (ft)				308	475	
pX, platoon unblocked	0.96					
vC, conflicting volume	963	318	338			
vC1, stage 1 conf vol						
vC2, stage 2 conf vol						
vCu, unblocked vol	942	318	338			
tC, single (s)	6.4	6.2	4.1			
tC, 2 stage (s)						
tF (s)	3.5	3.3	2.2			
p0 queue free %	84	93	93			
cM capacity (veh/h)	261	724	1231			
Direction, Lane #	EB 1	NB 1	NB 2	SB 1		
Volume Total	90	89	460	337		
Volume Left	41	89	0	0		
Volume Right	49	0	0	48		
cSH	402	1231	1700	1700		
Volume to Capacity	0.22	0.07	0.27	0.20		
Queue Length 95th (ft)	22	6	0	0		
Control Delay (s)	16.5	8.2	0.0	0.0		
Lane LOS	C	A				
Approach Delay (s)	16.5	1.3		0.0		
Approach LOS	C					
Intersection Summary						
Average Delay			2.3			
Intersection Capacity Utilization			37.1%	ICU Level of Service	A	
Analysis Period (min)			15			

HCM Unsignalized Intersection Capacity Analysis

6: Site Entrance 2 & Martinazzi Ave

4/17/2013



Movement	WBL	WBR	NBT	NBR	SBL	SBT
Lane Configurations	Y		T			T↑
Volume (veh/h)	5	25	475	9	3	305
Sign Control	Stop		Free			Free
Grade	0%		0%			0%
Peak Hour Factor	0.90	0.90	0.90	0.90	0.90	0.90
Hourly flow rate (vph)	6	28	528	10	3	339
Pedestrians	19					2
Lane Width (ft)	12.0					12.0
Walking Speed (ft/s)	4.0					4.0
Percent Blockage	2					0
Right turn flare (veh)						
Median type			None			None
Median storage (veh)						
Upstream signal (ft)			227			556
pX, platoon unblocked	0.90	0.90			0.90	
vC, conflicting volume	728	554			557	
vC1, stage 1 conf vol						
vC2, stage 2 conf vol						
vCu, unblocked vol	641	448			451	
tC, single (s)	6.8	6.9			4.1	
tC, 2 stage (s)						
tF (s)	3.5	3.3			2.2	
p0 queue free %	98	94			100	
cM capacity (veh/h)	363	498			991	

Direction, Lane #	WB 1	NB 1	SB 1	SB 2
Volume Total	33	538	116	226
Volume Left	6	0	3	0
Volume Right	28	10	0	0
cSH	469	1700	991	1700
Volume to Capacity	0.07	0.32	0.00	0.13
Queue Length 95th (ft)	6	0	0	0
Control Delay (s)	13.3	0.0	0.3	0.0
Lane LOS	B		A	
Approach Delay (s)	13.3	0.0	0.1	
Approach LOS	B			

Intersection Summary			
Average Delay		0.5	
Intersection Capacity Utilization		36.2%	ICU Level of Service A
Analysis Period (min)		15	

HCM Unsignalized Intersection Capacity Analysis
7: RO Only & Martinazzi Ave

4/17/2013



Movement	WBL	WBR	NBT	NBR	SBL	SBT
Lane Configurations		↗	↑			↘↘
Volume (veh/h)	0	10	474	0	1	309
Sign Control	Stop		Free			Free
Grade	0%		0%			0%
Peak Hour Factor	0.89	0.89	0.89	0.89	0.89	0.89
Hourly flow rate (vph)	0	11	533	0	1	347
Pedestrians	13					
Lane Width (ft)	12.0					
Walking Speed (ft/s)	4.0					
Percent Blockage	1					
Right turn flare (veh)						
Median type			None			None
Median storage (veh)						
Upstream signal (ft)			125			658
pX, platoon unblocked	0.89	0.89			0.89	
vC, conflicting volume	721	546			546	
vC1, stage 1 conf vol						
vC2, stage 2 conf vol						
vCu, unblocked vol	623	425			425	
tC, single (s)	6.8	6.9			4.1	
tC, 2 stage (s)						
tF (s)	3.5	3.3			2.2	
p0 queue free %	100	98			100	
cM capacity (veh/h)	371	512			1006	





















Direction, Lane #	WB 1	NB 1	SB 1	SB 2
Volume Total	11	533	117	231
Volume Left	0	0	1	0
Volume Right	11	0	0	0
cSH	512	1700	1006	1700
Volume to Capacity	0.02	0.31	0.00	0.14
Queue Length 95th (ft)	2	0	0	0
Control Delay (s)	12.2	0.0	0.1	0.0
Lane LOS	B		A	
Approach Delay (s)	12.2	0.0	0.0	
Approach LOS	B			

Intersection Summary			
Average Delay		0.2	
Intersection Capacity Utilization		34.9%	ICU Level of Service A
Analysis Period (min)		15	

HCM Signalized Intersection Capacity Analysis

8: Nyberg St & Martinazzi Ave

4/17/2013

												
Movement	EBL	EBT	EBR	WBL	WBT	WBR	NBL	NBT	NBR	SBL	SBT	SBR
Lane Configurations												
Volume (vph)	16	1	63	220	37	230	23	228	31	0	301	8
Ideal Flow (vphpl)	1900	1900	1900	1900	1900	1900	1900	1900	1900	1900	1900	1900
Total Lost time (s)	5.5	5.5		5.5	5.5	5.5	5.5	5.5			5.5	
Lane Util. Factor	1.00	1.00		0.95	0.95	1.00	1.00	1.00			0.95	
Frbp, ped/bikes	1.00	1.00		1.00	1.00	0.97	1.00	1.00			1.00	
Flpb, ped/bikes	1.00	1.00		1.00	1.00	1.00	1.00	1.00			1.00	
Frt	1.00	0.85		1.00	1.00	0.85	1.00	0.98			1.00	
Flt Protected	0.95	1.00		0.95	0.97	1.00	0.95	1.00			1.00	
Satd. Flow (prot)	1805	1603		1698	1730	1542	1683	1841			3559	
Flt Permitted	0.95	1.00		0.95	0.97	1.00	0.55	1.00			1.00	
Satd. Flow (perm)	1805	1603		1698	1730	1542	970	1841			3559	
Peak-hour factor, PHF	0.91	0.91	0.91	0.91	0.91	0.91	0.91	0.91	0.91	0.91	0.91	0.91
Adj. Flow (vph)	18	1	69	242	41	253	25	251	34	0	331	9
RTOR Reduction (vph)	0	63	0	0	0	198	0	7	0	0	3	0
Lane Group Flow (vph)	18	7	0	140	143	55	25	278	0	0	337	0
Confl. Peds. (#/hr)	2					2	3		16	16		3
Confl. Bikes (#/hr)						2						3
Heavy Vehicles (%)	0%	0%	1%	1%	0%	2%	7%	1%	0%	0%	1%	0%
Turn Type	Split			Split			Perm	Perm				
Protected Phases	8	8		4	4			6				2
Permitted Phases						4	6					
Actuated Green, G (s)	3.1	3.1		8.9	8.9	8.9	13.6	13.6				13.6
Effective Green, g (s)	3.6	3.6		9.4	9.4	9.4	14.1	14.1				14.1
Actuated g/C Ratio	0.08	0.08		0.22	0.22	0.22	0.32	0.32				0.32
Clearance Time (s)	6.0	6.0		6.0	6.0	6.0	6.0	6.0				6.0
Vehicle Extension (s)	2.5	2.5		2.5	2.5	2.5	5.0	5.0				5.0
Lane Grp Cap (vph)	149	132		366	373	332	314	595				1151
v/s Ratio Prot	c0.01	0.00		0.08	c0.08			c0.15				0.09
v/s Ratio Perm						0.04	0.03					
v/c Ratio	0.12	0.05		0.38	0.38	0.16	0.08	0.47				0.29
Uniform Delay, d1	18.5	18.4		14.6	14.6	13.9	10.2	11.8				11.0
Progression Factor	1.00	1.00		1.00	1.00	1.00	1.00	1.00				1.00
Incremental Delay, d2	0.3	0.1		0.5	0.5	0.2	0.2	1.2				0.3
Delay (s)	18.8	18.5		15.1	15.1	14.1	10.5	13.0				11.3
Level of Service	B	B		B	B	B	B	B				B
Approach Delay (s)		18.6			14.6			12.8				11.3
Approach LOS		B			B			B				B

Intersection Summary

HCM Average Control Delay	13.6	HCM Level of Service	B
HCM Volume to Capacity ratio	0.39		
Actuated Cycle Length (s)	43.6	Sum of lost time (s)	16.5
Intersection Capacity Utilization	47.4%	ICU Level of Service	A
Analysis Period (min)	15		

c Critical Lane Group

HCM Unsignalized Intersection Capacity Analysis

9: Nyberg St & Site Entrance 3

4/17/2013



Movement	EBL	EBT	WBT	WBR	SBL	SBR
Lane Configurations	↔		↕↔			↕↔
Volume (veh/h)	32	0	434	50	0	53
Sign Control		Free	Free		Stop	
Grade		0%	0%		0%	
Peak Hour Factor	0.88	0.88	0.88	0.88	0.88	0.88
Hourly flow rate (vph)	36	0	493	57	0	60
Pedestrians					4	
Lane Width (ft)					12.0	
Walking Speed (ft/s)					4.0	
Percent Blockage					0	
Right turn flare (veh)						
Median type		None	None			
Median storage (veh)						
Upstream signal (ft)		245				
pX, platoon unblocked						
vC, conflicting volume	554				598	279
vC1, stage 1 conf vol						
vC2, stage 2 conf vol						
vCu, unblocked vol	554				598	279
tC, single (s)	4.1				6.8	6.9
tC, 2 stage (s)						
tF (s)	2.2				3.5	3.3
p0 queue free %	96				100	92
cM capacity (veh/h)	1023				421	722
Direction, Lane #	EB 1	WB 1	WB 2	SB 1		
Volume Total	36	329	221	60		
Volume Left	36	0	0	0		
Volume Right	0	0	57	60		
cSH	1023	1700	1700	722		
Volume to Capacity	0.04	0.19	0.13	0.08		
Queue Length 95th (ft)	3	0	0	7		
Control Delay (s)	8.6	0.0	0.0	10.4		
Lane LOS	A			B		
Approach Delay (s)	8.6	0.0		10.4		
Approach LOS				B		
Intersection Summary						
Average Delay			1.5			
Intersection Capacity Utilization			23.6%		ICU Level of Service	A
Analysis Period (min)			15			

HCM Signalized Intersection Capacity Analysis
 10: Tualatin Sherwood Rd & Site Entrance 4

4/17/2013

Movement	EBL	EBT	EBR	WBL	WBT	WBR	NBL	NBT	NBR	SBL	SBT	SBR
Lane Configurations												
Volume (vph)	50	1335	59	257	1451	101	57	25	248	154	40	62
Ideal Flow (vphpl)	1900	1900	1900	1900	1900	1900	1900	1900	1900	1900	1900	1900
Total Lost time (s)	4.5	6.0		4.5	6.0			5.0	4.5		5.0	5.0
Lane Util. Factor	1.00	*0.75		0.97	0.91			1.00	1.00		1.00	1.00
Frbp, ped/bikes	1.00	1.00		1.00	1.00			1.00	1.00		1.00	0.98
Flpb, ped/bikes	1.00	1.00		1.00	1.00			1.00	1.00		1.00	1.00
Frt	1.00	0.99		1.00	0.99			1.00	0.85		1.00	0.85
Flt Protected	0.95	1.00		0.95	1.00			0.97	1.00		0.96	1.00
Satd. Flow (prot)	1805	4091		3502	4941			1799	1599		1813	1579
Flt Permitted	0.95	1.00		0.95	1.00			0.50	1.00		0.71	1.00
Satd. Flow (perm)	1805	4091		3502	4941			925	1599		1347	1579
Peak-hour factor, PHF	0.98	0.98	0.98	0.98	0.98	0.98	0.98	0.98	0.98	0.98	0.98	0.98
Adj. Flow (vph)	51	1362	60	262	1481	103	58	26	253	157	41	63
RTOR Reduction (vph)	0	3	0	0	5	0	0	0	0	0	0	52
Lane Group Flow (vph)	51	1419	0	262	1579	0	0	84	253	0	198	11
Confl. Peds. (#/hr)							4					9
Confl. Bikes (#/hr)					1			1		1		
Heavy Vehicles (%)	0%	4%	0%	0%	4%	0%	3%	0%	1%	1%	0%	0%
Turn Type	Prot			Prot			Perm		pm+ov	Perm		Perm
Protected Phases	5	2		1	6			8	1		4	
Permitted Phases							8		8	4		4
Actuated Green, G (s)	5.9	66.0		11.6	71.7			20.4	32.0		20.4	20.4
Effective Green, g (s)	6.4	66.5		12.1	72.2			20.9	33.0		20.9	20.9
Actuated g/C Ratio	0.06	0.58		0.11	0.63			0.18	0.29		0.18	0.18
Clearance Time (s)	5.0	6.5		5.0	6.5			5.5	5.0		5.5	5.5
Vehicle Extension (s)	2.5	4.0		2.5	4.0			2.5	2.5		2.5	2.5
Lane Grp Cap (vph)	100	2366		368	3102			168	459		245	287
v/s Ratio Prot	0.03	c0.35		c0.07	0.32				0.06			
v/s Ratio Perm								0.09	0.10		c0.15	0.01
v/c Ratio	0.51	0.60		0.71	0.51			0.50	0.55		0.81	0.04
Uniform Delay, d1	52.8	15.7		49.8	11.7			42.3	34.7		45.1	38.8
Progression Factor	0.84	0.72		1.01	0.63			1.00	1.00		1.00	1.00
Incremental Delay, d2	2.6	0.9		4.9	0.5			1.7	1.1		17.1	0.0
Delay (s)	47.0	12.2		55.2	7.8			44.0	35.9		62.2	38.8
Level of Service	D	B		E	A			D	D		E	D
Approach Delay (s)		13.4			14.6			37.9			56.5	
Approach LOS		B			B			D			E	

Intersection Summary

HCM Average Control Delay	18.9	HCM Level of Service	B
HCM Volume to Capacity ratio	0.66		
Actuated Cycle Length (s)	115.0	Sum of lost time (s)	15.5
Intersection Capacity Utilization	69.5%	ICU Level of Service	C
Analysis Period (min)	15		

c Critical Lane Group

HCM Unsignalized Intersection Capacity Analysis
 11: Tualatin Sherwood Rd & 75th Ave

4/17/2013

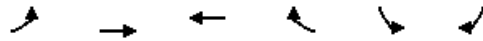













Movement	EBL	EBT	WBT	WBR	SBL	SBR	
Lane Configurations		↑↑↑	↑↑↑			↗	
Volume (veh/h)	0	1737	1794	48	0	15	
Sign Control		Free	Free		Stop		
Grade		0%	0%		0%		
Peak Hour Factor	0.97	0.97	0.97	0.97	0.97	0.97	
Hourly flow rate (vph)	0	1791	1849	49	0	15	
Pedestrians					6		
Lane Width (ft)					12.0		
Walking Speed (ft/s)					4.0		
Percent Blockage					1		
Right turn flare (veh)							
Median type		None	None				
Median storage (veh)							
Upstream signal (ft)		373	260				
pX, platoon unblocked	0.84				0.88	0.84	
vC, conflicting volume	1905				2477	647	
vC1, stage 1 conf vol							
vC2, stage 2 conf vol							
vCu, unblocked vol	1407				982	0	
tC, single (s)	4.1				6.8	7.4	
tC, 2 stage (s)							
tF (s)	2.2				3.5	3.5	
p0 queue free %	100				100	98	
cM capacity (veh/h)	410				220	847	
Direction, Lane #	EB 1	EB 2	EB 3	WB 1	WB 2	WB 3	SB 1
Volume Total	597	597	597	740	740	419	15
Volume Left	0	0	0	0	0	0	0
Volume Right	0	0	0	0	0	49	15
cSH	1700	1700	1700	1700	1700	1700	847
Volume to Capacity	0.35	0.35	0.35	0.44	0.44	0.25	0.02
Queue Length 95th (ft)	0	0	0	0	0	0	1
Control Delay (s)	0.0	0.0	0.0	0.0	0.0	0.0	9.3
Lane LOS							A
Approach Delay (s)	0.0			0.0			9.3
Approach LOS							A
Intersection Summary							
Average Delay			0.0				
Intersection Capacity Utilization			45.7%		ICU Level of Service		A
Analysis Period (min)			15				

HCM Signalized Intersection Capacity Analysis

12: Tualatin Sherwood Rd & I-5 SB Ramps













4/17/2013

													
Movement	EBL	EBT	EBR	WBL	WBT	WBR	NBL	NBT	NBR	SBL	SBT	SBR	
Lane Configurations		↑↑↑	↗	↘	↑↑					↘	↗	↗↗	
Volume (vph)	0	1332	405	187	1000	0	0	0	0	602	3	840	
Ideal Flow (vphpl)	1900	1900	1900	1900	1900	1900	1900	1900	1900	1900	1900	1900	
Total Lost time (s)		5.5	5.5	3.5	5.5					5.5	5.5	5.5	
Lane Util. Factor		*0.75	1.00	1.00	0.95					0.95	0.95	0.88	
Frbp, ped/bikes		1.00	1.00	1.00	1.00					1.00	1.00	1.00	
Flpb, ped/bikes		1.00	1.00	1.00	1.00					1.00	1.00	1.00	
Frt		1.00	0.85	1.00	1.00					1.00	1.00	0.85	
Flt Protected		1.00	1.00	0.95	1.00					0.95	0.95	1.00	
Satd. Flow (prot)		4150	1568	1787	3471					1681	1683	2760	
Flt Permitted		1.00	1.00	0.95	1.00					0.95	0.95	1.00	
Satd. Flow (perm)		4150	1568	1787	3471					1681	1683	2760	
Peak-hour factor, PHF	0.99	0.99	0.99	0.99	0.99	0.99	0.99	0.99	0.99	0.99	0.99	0.99	
Adj. Flow (vph)	0	1345	409	189	1010	0	0	0	0	608	3	848	
RTOR Reduction (vph)	0	0	199	0	0	0	0	0	0	0	0	68	
Lane Group Flow (vph)	0	1345	210	189	1010	0	0	0	0	304	307	780	
Confl. Bikes (#/hr)		1			2								
Heavy Vehicles (%)	0%	3%	3%	1%	4%	0%	0%	0%	0%	2%	20%	3%	
Turn Type			Perm	Prot						Split		custom	
Protected Phases		2		1	6					4	4	4.5	
Permitted Phases			2										
Actuated Green, G (s)		57.4	57.4	14.7	59.1					26.9	26.9	43.9	
Effective Green, g (s)		57.9	57.9	15.2	59.6					27.4	27.4	40.9	
Actuated g/C Ratio		0.50	0.50	0.13	0.52					0.24	0.24	0.36	
Clearance Time (s)		6.0	6.0	4.0	6.0					6.0	6.0		
Vehicle Extension (s)		6.1	6.1	2.3	6.1					2.3	2.3		
Lane Grp Cap (vph)		2089	789	236	1799					401	401	982	
v/s Ratio Prot		c0.32		c0.11	0.29					0.18	0.18	c0.28	
v/s Ratio Perm			0.13										
v/c Ratio		0.64	0.27	0.80	0.56					0.76	0.77	0.79	
Uniform Delay, d1		21.0	16.4	48.4	18.8					40.7	40.8	33.3	
Progression Factor		0.72	0.65	0.72	1.23					1.00	1.00	1.00	
Incremental Delay, d2		1.3	0.7	16.2	1.2					7.4	7.9	4.3	
Delay (s)		16.3	11.3	51.0	24.5					48.1	48.7	37.6	
Level of Service		B	B	D	C					D	D	D	
Approach Delay (s)		15.1			28.6			0.0			42.1		
Approach LOS		B			C			A			D		
Intersection Summary													
HCM Average Control Delay			27.7		HCM Level of Service					C			
HCM Volume to Capacity ratio			0.77										
Actuated Cycle Length (s)			115.0		Sum of lost time (s)			20.0					
Intersection Capacity Utilization			66.2%		ICU Level of Service			C					
Analysis Period (min)			15										
c Critical Lane Group													

HCM Signalized Intersection Capacity Analysis

13: Tualatin Sherwood Rd & I-5 NB Ramps





















4/17/2013

													
Movement	EBL	EBT	EBR	WBL	WBT	WBR	NBL	NBT	NBR	SBL	SBT	SBR	
Lane Configurations		↑↑	↑↑		↑↑	↑	↑	↑	↑				
Volume (vph)	0	1045	890	0	610	646	575	0	213	0	0	0	
Ideal Flow (vphpl)	1900	1900	1900	1900	1900	1900	1900	1900	1900	1900	1900	1900	
Total Lost time (s)		5.5	5.5		6.0	6.0	5.5	5.5	5.5				
Lane Util. Factor		0.95	0.88		0.95	1.00	0.95	0.95	1.00				
Frbp, ped/bikes		1.00	0.98		1.00	1.00	1.00	1.00	0.98				
Flpb, ped/bikes		1.00	1.00		1.00	1.00	1.00	1.00	1.00				
Frt		1.00	0.85		1.00	0.85	1.00	1.00	0.85				
Flt Protected		1.00	1.00		1.00	1.00	0.95	0.95	1.00				
Satd. Flow (prot)		3574	2694		3574	1583	1618	1618	1559				
Flt Permitted		1.00	1.00		1.00	1.00	0.95	0.95	1.00				
Satd. Flow (perm)		3574	2694		3574	1583	1618	1618	1559				
Peak-hour factor, PHF	0.95	0.95	0.95	0.95	0.95	0.95	0.95	0.95	0.95	0.95	0.95	0.95	
Adj. Flow (vph)	0	1100	937	0	642	680	605	0	224	0	0	0	
RTOR Reduction (vph)	0	0	313	0	0	230	0	0	37	0	0	0	
Lane Group Flow (vph)	0	1100	624	0	642	450	302	303	187	0	0	0	
Confl. Peds. (#/hr)			1	1			1		2	2		1	
Confl. Bikes (#/hr)		1			5					1			
Heavy Vehicles (%)	0%	1%	3%	0%	1%	2%	6%	20%	2%	0%	0%	0%	
Turn Type			Perm			Perm	Split		Perm				
Protected Phases		2			6		8	8					
Permitted Phases			2			6			8				
Actuated Green, G (s)		76.1	76.1		75.6	75.6	26.9	26.9	26.9				
Effective Green, g (s)		76.6	76.6		76.1	76.1	27.4	27.4	27.4				
Actuated g/C Ratio		0.67	0.67		0.66	0.66	0.24	0.24	0.24				
Clearance Time (s)		6.0	6.0		6.5	6.5	6.0	6.0	6.0				
Vehicle Extension (s)		6.1	6.1		4.2	4.2	2.3	2.3	2.3				
Lane Grp Cap (vph)		2381	1794		2365	1048	386	386	371				
v/s Ratio Prot		c0.31			0.18		0.19	c0.19					
v/s Ratio Perm			0.23			0.28			0.12				
v/c Ratio		0.46	0.35		0.27	0.43	0.78	0.78	0.51				
Uniform Delay, d1		9.3	8.3		8.0	9.2	41.0	41.0	37.9				
Progression Factor		1.29	5.34		1.00	1.00	1.00	1.00	1.00				
Incremental Delay, d2		0.5	0.4		0.3	1.3	9.4	9.6	0.6				
Delay (s)		12.5	45.0		8.3	10.5	50.4	50.6	38.6				
Level of Service		B	D		A	B	D	D	D				
Approach Delay (s)		27.5			9.4			47.3			0.0		
Approach LOS		C			A			D			A		
Intersection Summary													
HCM Average Control Delay			25.7		HCM Level of Service				C				
HCM Volume to Capacity ratio			0.55										
Actuated Cycle Length (s)			115.0		Sum of lost time (s)				11.0				
Intersection Capacity Utilization			65.5%		ICU Level of Service				C				
Analysis Period (min)			15										

c Critical Lane Group

HCM Signalized Intersection Capacity Analysis
 14: Tualatin Sherwood Rd & Nyberg Woods

4/17/2013

													
Movement	EBL	EBT	EBR	WBL	WBT	WBR	NBL	NBT	NBR	SBL	SBT	SBR	
Lane Configurations													
Volume (vph)	524	544	57	15	672	101	103	11	12	101	11	322	
Ideal Flow (vphpl)	1900	1900	1900	1900	1900	1900	1900	1900	1900	1900	1900	1900	
Total Lost time (s)	5.5	5.5		5.5	5.5			5.5	5.5		5.5	5.5	
Lane Util. Factor	0.97	0.95		1.00	0.95			1.00	1.00		1.00	1.00	
Frbp, ped/bikes	1.00	1.00		1.00	1.00			1.00	0.99		1.00	0.99	
Flpb, ped/bikes	1.00	1.00		1.00	1.00			1.00	1.00		1.00	1.00	
Frt	1.00	0.99		1.00	0.98			1.00	0.85		1.00	0.85	
Flt Protected	0.95	1.00		0.95	1.00			0.96	1.00		0.96	1.00	
Satd. Flow (prot)	3502	3481		1805	3500			1768	1593		1799	1594	
Flt Permitted	0.95	1.00		0.95	1.00			0.66	1.00		0.66	1.00	
Satd. Flow (perm)	3502	3481		1805	3500			1229	1593		1249	1594	
Peak-hour factor, PHF	0.96	0.96	0.96	0.96	0.96	0.96	0.96	0.96	0.96	0.96	0.96	0.96	
Adj. Flow (vph)	546	567	59	16	700	105	107	11	12	105	11	335	
RTOR Reduction (vph)	0	6	0	0	11	0	0	0	10	0	0	282	
Lane Group Flow (vph)	546	620	0	16	794	0	0	118	2	0	116	53	
Confl. Peds. (#/hr)	8		2	2		8	1		2	2		1	
Confl. Bikes (#/hr)		1			3								
Heavy Vehicles (%)	0%	2%	2%	0%	1%	0%	3%	0%	0%	1%	0%	0%	
Turn Type	Prot			Prot			Perm		Perm	Perm		Perm	
Protected Phases	5	2		1	6			8				4	
Permitted Phases							8		8	4		4	
Actuated Green, G (s)	13.8	35.6		0.8	22.6			9.7	9.7			9.7	
Effective Green, g (s)	14.3	36.1		1.3	23.1			10.2	10.2			10.2	
Actuated g/C Ratio	0.22	0.56		0.02	0.36			0.16	0.16			0.16	
Clearance Time (s)	6.0	6.0		6.0	6.0			6.0	6.0			6.0	
Vehicle Extension (s)	2.3	2.5		2.4	2.5			2.4	2.4			2.3	
Lane Grp Cap (vph)	781	1960		37	1261			196	253			199	
v/s Ratio Prot	c0.16	0.18		0.01	c0.23								
v/s Ratio Perm								c0.10	0.00			0.09	
v/c Ratio	0.70	0.32		0.43	0.63			0.60	0.01			0.58	
Uniform Delay, d1	22.9	7.4		31.0	17.0			25.1	22.7			25.0	
Progression Factor	1.00	1.00		1.00	1.00			1.00	1.00			1.00	
Incremental Delay, d2	2.4	0.1		5.2	0.9			4.2	0.0			3.3	
Delay (s)	25.3	7.5		36.3	17.8			29.2	22.7			28.2	
Level of Service	C	A		D	B			C	C			C	
Approach Delay (s)		15.8			18.2			28.6				24.9	
Approach LOS		B			B			C				C	























Intersection Summary

HCM Average Control Delay	18.8	HCM Level of Service	B
HCM Volume to Capacity ratio	0.64		
Actuated Cycle Length (s)	64.1	Sum of lost time (s)	16.5
Intersection Capacity Utilization	63.9%	ICU Level of Service	B
Analysis Period (min)	15		

c Critical Lane Group

HCM Signalized Intersection Capacity Analysis
 17: Tualatin Sherwood Rd & Martinazzi Ave

4/17/2013

												
Movement	EBL	EBT	EBR	WBL	WBT	WBR	NBL	NBT	NBR	SBL	SBT	SBR
Lane Configurations		 			 						 	
Volume (vph)	67	1110	137	0	1086	0	97	215	210	125	371	85
Ideal Flow (vphpl)	1900	1900	1900	1900	1900	1900	1900	1900	1900	1900	1900	1900
Total Lost time (s)	4.5	5.5			5.5		4.5	5.5	5.5	4.5	5.5	
Lane Util. Factor	1.00	0.95			0.95		1.00	1.00	1.00	1.00	0.95	
Frpb, ped/bikes	1.00	1.00			1.00		1.00	1.00	0.96	1.00	1.00	
Flpb, ped/bikes	1.00	1.00			1.00		1.00	1.00	1.00	1.00	1.00	
Frt	1.00	0.98			1.00		1.00	1.00	0.85	1.00	0.97	
Flt Protected	0.95	1.00			1.00		0.95	1.00	1.00	0.95	1.00	
Satd. Flow (prot)	1719	3428			3438		1770	1863	1537	1787	3465	
Flt Permitted	0.95	1.00			1.00		0.95	1.00	1.00	0.95	1.00	
Satd. Flow (perm)	1719	3428			3438		1770	1863	1537	1787	3465	
Peak-hour factor, PHF	0.94	0.94	0.94	0.94	0.94	0.94	0.94	0.94	0.94	0.94	0.94	0.94
Adj. Flow (vph)	71	1181	146	0	1155	0	103	229	223	133	395	90
RTOR Reduction (vph)	0	6	0	0	0	0	0	0	113	0	20	0
Lane Group Flow (vph)	71	1321	0	0	1155	0	103	229	110	133	465	0
Confl. Peds. (#/hr)							6		23			3
Heavy Vehicles (%)	5%	4%	0%	0%	5%	0%	2%	2%	1%	1%	1%	1%
Turn Type	Prot						Prot		Perm	Prot		
Protected Phases	5	2			6		3	8		7	4	
Permitted Phases									8			
Actuated Green, G (s)	7.4	67.9			55.5		10.4	17.4	17.4	12.7	19.7	
Effective Green, g (s)	7.9	68.4			56.0		10.9	17.9	17.9	13.2	20.2	
Actuated g/C Ratio	0.07	0.59			0.49		0.09	0.16	0.16	0.11	0.18	
Clearance Time (s)	5.0	6.0			6.0		5.0	6.0	6.0	5.0	6.0	
Vehicle Extension (s)	2.0	3.5			3.5		3.0	2.0	2.0	3.0	2.0	
Lane Grp Cap (vph)	118	2039			1674		168	290	239	205	609	
v/s Ratio Prot	0.04	c0.39			c0.34		0.06	c0.12		0.07	c0.13	
v/s Ratio Perm									0.07			
v/c Ratio	0.60	0.65			0.69		0.61	0.79	0.46	0.65	0.76	
Uniform Delay, d1	52.0	15.4			22.8		50.0	46.7	44.2	48.7	45.1	
Progression Factor	1.00	1.00			0.51		1.00	1.00	1.00	1.00	1.00	
Incremental Delay, d2	5.8	1.6			2.1		6.5	12.4	0.5	6.9	5.1	
Delay (s)	57.8	17.0			13.9		56.5	59.1	44.7	55.6	50.2	
Level of Service	E	B			B		E	E	D	E	D	
Approach Delay (s)		19.0			13.9			52.8			51.4	
Approach LOS		B			B			D			D	
Intersection Summary												
HCM Average Control Delay			27.8				HCM Level of Service			C		
HCM Volume to Capacity ratio			0.76									
Actuated Cycle Length (s)			115.0				Sum of lost time (s)		22.0			
Intersection Capacity Utilization			78.5%				ICU Level of Service		D			
Analysis Period (min)			15									
c Critical Lane Group												





















Intersection Sign configuration not allowed in HCM analysis.

Appendix E
2014 Background Operations
Worksheets

HCM Signalized Intersection Capacity Analysis

1: SW Lower Boones Ferry Road & SW Upper Boones Ferry Road















4/15/2013

												
Movement	EBL	EBT	EBR	WBL	WBT	WBR	NBL	NBT	NBR	SBL	SBT	SBR
Lane Configurations												
Volume (vph)	1	7	9	469	7	40	0	484	557	59	676	1
Ideal Flow (vphpl)	1900	1900	1900	1900	1900	1900	1900	1900	1900	1900	1900	1900
Total Lost time (s)		3.5		3.5	3.5			4.0	3.5	3.5	4.0	
Lane Util. Factor		1.00		1.00	1.00			1.00	1.00	1.00	1.00	
Frbp, ped/bikes		0.92		1.00	0.96			1.00	0.98	1.00	1.00	
Flpb, ped/bikes		1.00		1.00	1.00			1.00	1.00	1.00	1.00	
Frt		0.93		1.00	0.87			1.00	0.85	1.00	1.00	
Flt Protected		1.00		0.95	1.00			1.00	1.00	0.95	1.00	
Satd. Flow (prot)		1597		1787	1575			1900	1571	1805	1900	
Flt Permitted		1.00		0.95	1.00			1.00	1.00	0.95	1.00	
Satd. Flow (perm)		1597		1787	1575			1900	1571	1805	1900	
Peak-hour factor, PHF	0.95	0.95	0.95	0.95	0.95	0.95	0.95	0.95	0.95	0.95	0.95	0.95
Adj. Flow (vph)	1	7	9	494	7	42	0	509	586	62	712	1
RTOR Reduction (vph)	0	9	0	0	26	0	0	0	157	0	0	0
Lane Group Flow (vph)	0	8	0	494	23	0	0	509	429	62	713	0
Confl. Peds. (#/hr)	15		7	7		15	7		8	8		7
Heavy Vehicles (%)	0%	2%	1%	1%	3%	0%	2%	0%	1%	0%	0%	0%
Turn Type	Split			Split			Prot		pm+ov		Prot	
Protected Phases	8	8		4	4		1	6	4	5	2	
Permitted Phases									6			
Actuated Green, G (s)		1.7		32.0	32.0			28.3	60.3	5.3	37.6	
Effective Green, g (s)		2.2		32.5	32.5			28.8	61.3	5.8	38.1	
Actuated g/C Ratio		0.03		0.39	0.39			0.34	0.73	0.07	0.45	
Clearance Time (s)		4.0		4.0	4.0			4.5	4.0	4.0	4.5	
Vehicle Extension (s)		2.5		2.2	2.2			3.5	2.2	2.2	3.5	
Lane Grp Cap (vph)		42		693	611			653	1149	125	864	
v/s Ratio Prot		c0.01		c0.28	0.01			0.27	0.14	0.03	c0.38	
v/s Ratio Perm									0.13			
v/c Ratio		0.20		0.71	0.04			0.78	0.37	0.50	0.83	
Uniform Delay, d1		39.9		21.7	15.9			24.7	4.2	37.6	19.9	
Progression Factor		1.00		1.00	1.00			1.00	1.00	1.00	1.00	
Incremental Delay, d2		1.7		3.0	0.0			6.0	0.1	1.6	6.6	
Delay (s)		41.6		24.7	16.0			30.7	4.3	39.2	26.6	
Level of Service		D		C	B			C	A	D	C	
Approach Delay (s)		41.6			23.9			16.5			27.6	
Approach LOS		D			C			B			C	
Intersection Summary												
HCM Average Control Delay			21.9			HCM Level of Service				C		
HCM Volume to Capacity ratio			0.76									
Actuated Cycle Length (s)			83.8			Sum of lost time (s)			11.0			
Intersection Capacity Utilization			81.6%			ICU Level of Service				D		
Analysis Period (min)			15									
c Critical Lane Group												

HCM Signalized Intersection Capacity Analysis

2: SW Boones Ferry Rd & SW Tualatin Rd

4/15/2013

						
Movement	WBL	WBR	NBT	NBR	SBL	SBT
Lane Configurations	 			 	 	
Volume (vph)	410	834	200	298	443	365
Ideal Flow (vphpl)	1900	1900	1900	1900	1900	1900
Total Lost time (s)	3.5	3.5	3.0	3.5	3.5	3.5
Lane Util. Factor	0.97	1.00	1.00	1.00	1.00	1.00
Frbp, ped/bikes	1.00	0.98	1.00	0.98	1.00	1.00
Flpb, ped/bikes	1.00	1.00	1.00	1.00	1.00	1.00
Frt	1.00	0.85	1.00	0.85	1.00	1.00
Flt Protected	0.95	1.00	1.00	1.00	0.95	1.00
Satd. Flow (prot)	3467	1589	1900	1571	1805	1900
Flt Permitted	0.95	1.00	1.00	1.00	0.95	1.00
Satd. Flow (perm)	3467	1589	1900	1571	1805	1900
Peak-hour factor, PHF	0.95	0.95	0.95	0.95	0.95	0.95
Adj. Flow (vph)	432	878	211	314	466	384
RTOR Reduction (vph)	0	196	0	74	0	0
Lane Group Flow (vph)	432	682	211	240	466	384
Confl. Peds. (#/hr)	7	15		8	8	
Heavy Vehicles (%)	1%	0%	0%	1%	0%	0%
Turn Type		pm+ov		pm+ov	Prot	
Protected Phases	8	1	2	8	1	6
Permitted Phases		8		2		
Actuated Green, G (s)	11.6	32.0	13.4	25.0	20.4	37.3
Effective Green, g (s)	12.1	33.0	13.9	26.0	20.9	37.8
Actuated g/C Ratio	0.21	0.58	0.24	0.46	0.37	0.66
Clearance Time (s)	4.0	4.0	3.5	4.0	4.0	4.0
Vehicle Extension (s)	3.0	2.0	5.0	3.0	2.0	2.0
Lane Grp Cap (vph)	737	1019	464	718	663	1262
v/s Ratio Prot	0.12	c0.25	c0.11	0.07	0.26	0.20
v/s Ratio Perm		0.18		0.08		
v/c Ratio	0.59	0.67	0.45	0.33	0.70	0.30
Uniform Delay, d1	20.1	8.2	18.3	9.9	15.4	4.0
Progression Factor	1.00	1.00	1.00	1.00	1.00	1.00
Incremental Delay, d2	1.2	1.3	1.5	0.3	2.8	0.0
Delay (s)	21.3	9.5	19.8	10.2	18.1	4.1
Level of Service	C	A	B	B	B	A
Approach Delay (s)	13.4		14.0			11.8
Approach LOS	B		B			B
Intersection Summary						
HCM Average Control Delay			13.0		HCM Level of Service	B
HCM Volume to Capacity ratio			0.61			
Actuated Cycle Length (s)			56.9		Sum of lost time (s)	6.5
Intersection Capacity Utilization			71.6%		ICU Level of Service	C
Analysis Period (min)			15			
c Critical Lane Group						

HCM Signalized Intersection Capacity Analysis
 3: SW Boones Fe & SW Martinazzi Ave

4/15/2013

	→	↘	↙	←	↖	↗
Movement	EBT	EBR	WBL	WBT	NBL	NBR
Lane Configurations	↑	↗	↘	↑	↘	↗
Volume (vph)	664	175	422	930	325	385
Ideal Flow (vphpl)	1900	1900	1900	1900	1900	1900
Total Lost time (s)	4.5	4.5	4.5	4.5	4.5	4.5
Lane Util. Factor	1.00	1.00	1.00	1.00	1.00	1.00
Frpb, ped/bikes	1.00	1.00	1.00	1.00	1.00	0.98
Flpb, ped/bikes	1.00	1.00	1.00	1.00	1.00	1.00
Fr t	1.00	0.85	1.00	1.00	1.00	0.85
Fl t Protected	1.00	1.00	0.95	1.00	0.95	1.00
Satd. Flow (prot)	1863	1599	1787	1845	1770	1572
Fl t Permitted	1.00	1.00	0.95	1.00	0.95	1.00
Satd. Flow (perm)	1863	1599	1787	1845	1770	1572
Peak-hour factor, PHF	0.95	0.95	0.95	0.95	0.95	0.95
Adj. Flow (vph)	699	184	444	979	342	405
RTOR Reduction (vph)	0	51	0	0	0	38
Lane Group Flow (vph)	699	133	444	979	342	367
Confl. Peds. (#/hr)		7	7		7	8
Confl. Bikes (#/hr)	4		2	10	1	
Heavy Vehicles (%)	2%	1%	1%	3%	2%	1%
Turn Type		Prot	Prot			pm+ov
Protected Phases	2	2	1	6	8	1
Permitted Phases					8	8
Actuated Green, G (s)	41.2	41.2	29.9	76.1	21.1	51.0
Effective Green, g (s)	41.7	41.7	30.4	76.6	21.6	52.0
Actuated g/C Ratio	0.39	0.39	0.28	0.71	0.20	0.49
Clearance Time (s)	5.0	5.0	5.0	5.0	5.0	5.0
Vehicle Extension (s)	3.0	3.0	3.0	3.0	3.0	3.0
Lane Grp Cap (vph)	725	622	507	1318	357	829
v/s Ratio Prot	c0.38	0.08	c0.25	0.53	c0.19	0.13
v/s Ratio Perm						0.11
v/c Ratio	0.96	0.21	0.88	0.74	0.96	0.44
Uniform Delay, d1	32.0	21.8	36.6	9.3	42.4	18.1
Progression Factor	1.00	1.00	1.00	1.00	1.00	1.00
Incremental Delay, d2	24.7	0.2	15.5	2.3	36.3	0.4
Delay (s)	56.7	22.0	52.1	11.6	78.6	18.5
Level of Service	E	C	D	B	E	B
Approach Delay (s)	49.5			24.2	46.0	
Approach LOS	D			C	D	

Intersection Summary			
HCM Average Control Delay	36.9	HCM Level of Service	D
HCM Volume to Capacity ratio	0.93		
Actuated Cycle Length (s)	107.2	Sum of lost time (s)	13.5
Intersection Capacity Utilization	87.6%	ICU Level of Service	E
Analysis Period (min)	15		

c Critical Lane Group

HCM Unsignalized Intersection Capacity Analysis

4: Site Entrance 1 & Martinazzi Ave

4/15/2013



Movement	WBL	WBR	NBT	NBR	SBL	SBT
Lane Configurations	↰	↱	↰		↰	↱
Volume (veh/h)	30	110	598	70	145	450
Sign Control	Stop		Free			Free
Grade	0%		0%			0%
Peak Hour Factor	0.91	0.91	0.91	0.91	0.91	0.91
Hourly flow rate (vph)	33	121	657	77	159	495
Pedestrians	25		16			26
Lane Width (ft)	12.0		12.0			12.0
Walking Speed (ft/s)	4.0		4.0			4.0
Percent Blockage	2		1			2
Right turn flare (veh)						
Median type			None			TWLTL
Median storage (veh)						2
Upstream signal (ft)			428			355
pX, platoon unblocked	0.91	0.91			0.91	
vC, conflicting volume	1550	747			759	
vC1, stage 1 conf vol	721					
vC2, stage 2 conf vol	829					
vCu, unblocked vol	1555	668			682	
tC, single (s)	6.4	6.2			4.1	
tC, 2 stage (s)	5.4					
tF (s)	3.5	3.3			2.2	
p0 queue free %	88	69			80	
cM capacity (veh/h)	276	393			795	
Direction, Lane #	WB 1	WB 2	NB 1	SB 1	SB 2	
Volume Total	33	121	734	159	495	
Volume Left	33	0	0	159	0	
Volume Right	0	121	77	0	0	
cSH	276	393	1700	795	1700	
Volume to Capacity	0.12	0.31	0.43	0.20	0.29	
Queue Length 95th (ft)	10	33	0	19	0	
Control Delay (s)	19.8	18.2	0.0	10.7	0.0	
Lane LOS	C	C		B		
Approach Delay (s)	18.5		0.0	2.6		
Approach LOS	C					
Intersection Summary						
Average Delay			3.0			
Intersection Capacity Utilization			63.1%		ICU Level of Service	B
Analysis Period (min)			15			

HCM Unsignalized Intersection Capacity Analysis

5: Seneca St & Martinazzi Ave

4/15/2013



Movement	EBL	EBR	NBL	NBT	SBT	SBR
Lane Configurations						
Volume (veh/h)	40	80	85	628	431	50
Sign Control	Stop			Free	Free	
Grade	0%			0%	0%	
Peak Hour Factor	0.89	0.89	0.89	0.89	0.89	0.89
Hourly flow rate (vph)	45	90	96	706	484	56
Pedestrians						
Lane Width (ft)						
Walking Speed (ft/s)						
Percent Blockage						
Right turn flare (veh)						
Median type				None	None	
Median storage (veh)						
Upstream signal (ft)				308	475	
pX, platoon unblocked	0.89					
vC, conflicting volume	1409	512	540			
vC1, stage 1 conf vol						
vC2, stage 2 conf vol						
vCu, unblocked vol	1398	512	540			
tC, single (s)	6.4	6.2	4.1			
tC, 2 stage (s)						
tF (s)	3.5	3.3	2.2			
p0 queue free %	65	84	91			
cM capacity (veh/h)	127	566	1038			
Direction, Lane #	EB 1	NB 1	NB 2	SB 1		
Volume Total	135	96	706	540		
Volume Left	45	96	0	0		
Volume Right	90	0	0	56		
cSH	263	1038	1700	1700		
Volume to Capacity	0.51	0.09	0.42	0.32		
Queue Length 95th (ft)	70	8	0	0		
Control Delay (s)	32.2	8.8	0.0	0.0		
Lane LOS	D	A				
Approach Delay (s)	32.2	1.1	0.0			
Approach LOS	D					
Intersection Summary						
Average Delay			3.5			
Intersection Capacity Utilization			47.6%	ICU Level of Service	A	
Analysis Period (min)			15			

HCM Unsignalized Intersection Capacity Analysis

6: Site Entrance 2 & Martinazzi Ave

4/15/2013



Movement	WBL	WBR	NBT	NBR	SBL	SBT
Lane Configurations	Y		T			T
Volume (veh/h)	0	32	681	6	10	502
Sign Control	Stop		Free			Free
Grade	0%		0%			0%
Peak Hour Factor	0.91	0.91	0.91	0.91	0.91	0.91
Hourly flow rate (vph)	0	35	748	7	11	552
Pedestrians	25		16			26
Lane Width (ft)	12.0		12.0			12.0
Walking Speed (ft/s)	4.0		4.0			4.0
Percent Blockage	2		1			2
Right turn flare (veh)						
Median type			None			None
Median storage (veh)						
Upstream signal (ft)			227			556
pX, platoon unblocked	0.86	0.86			0.86	
vC, conflicting volume	1090	803			780	
vC1, stage 1 conf vol						
vC2, stage 2 conf vol						
vCu, unblocked vol	1023	687			661	
tC, single (s)	6.9	7.0			4.2	
tC, 2 stage (s)						
tF (s)	3.5	3.3			2.2	
p0 queue free %	100	89			99	
cM capacity (veh/h)	185	314			759	
Direction, Lane #	WB 1	NB 1	SB 1	SB 2		
Volume Total	35	755	195	368		
Volume Left	0	0	11	0		
Volume Right	35	7	0	0		
cSH	314	1700	759	1700		
Volume to Capacity	0.11	0.44	0.01	0.22		
Queue Length 95th (ft)	10	0	1	0		
Control Delay (s)	17.9	0.0	0.7	0.0		
Lane LOS	C		A			
Approach Delay (s)	17.9	0.0	0.2			
Approach LOS	C					
Intersection Summary						
Average Delay			0.6			
Intersection Capacity Utilization			52.5%		ICU Level of Service	A
Analysis Period (min)			15			

HCM Unsignalized Intersection Capacity Analysis
7: RO Only & Martinazzi Ave





















4/15/2013

	↙	↖	↑	↗	↘	↓
Movement	WBL	WBR	NBT	NBR	SBL	SBT
Lane Configurations		↗	↑			↗↗
Volume (veh/h)	0	12	675	0	0	502
Sign Control	Stop		Free			Free
Grade	0%		0%			0%
Peak Hour Factor	0.89	0.89	0.89	0.89	0.89	0.89
Hourly flow rate (vph)	0	13	758	0	0	564
Pedestrians						
Lane Width (ft)						
Walking Speed (ft/s)						
Percent Blockage						
Right turn flare (veh)						
Median type	None			None		
Median storage (veh)						
Upstream signal (ft)	125			658		
pX, platoon unblocked	0.85	0.85			0.85	
vC, conflicting volume	1040	758			758	
vC1, stage 1 conf vol						
vC2, stage 2 conf vol						
vCu, unblocked vol	960	629			629	
tC, single (s)	6.8	6.9			4.1	
tC, 2 stage (s)						
tF (s)	3.5	3.3			2.2	
p0 queue free %	100	96			100	
cM capacity (veh/h)	220	366			820	
Direction, Lane #	WB 1	NB 1	SB 1	SB 2		
Volume Total	13	758	282	282		
Volume Left	0	0	0	0		
Volume Right	13	0	0	0		
cSH	366	1700	1700	1700		
Volume to Capacity	0.04	0.45	0.17	0.17		
Queue Length 95th (ft)	3	0	0	0		
Control Delay (s)	15.2	0.0	0.0	0.0		
Lane LOS	C					
Approach Delay (s)	15.2	0.0	0.0			
Approach LOS	C					
Intersection Summary						
Average Delay			0.2			
Intersection Capacity Utilization			45.5%	ICU Level of Service	A	
Analysis Period (min)			15			

HCM Signalized Intersection Capacity Analysis

8: Nyberg St & Martinazzi Ave

4/15/2013

												
Movement	EBL	EBT	EBR	WBL	WBT	WBR	NBL	NBT	NBR	SBL	SBT	SBR
Lane Configurations												
Volume (vph)	29	10	100	349	55	337	27	308	19	0	492	10
Ideal Flow (vphpl)	1900	1900	1900	1900	1900	1900	1900	1900	1900	1900	1900	1900
Total Lost time (s)	4.0	4.0		4.0	4.0	4.0	4.0	4.0			4.0	
Lane Util. Factor	1.00	1.00		0.95	0.95	1.00	1.00	1.00			0.95	
Frpb, ped/bikes	1.00	1.00		1.00	1.00	0.96	1.00	1.00			1.00	
Flpb, ped/bikes	1.00	1.00		1.00	1.00	1.00	1.00	1.00			1.00	
Frt	1.00	0.86		1.00	1.00	0.85	1.00	0.99			1.00	
Flt Protected	0.95	1.00		0.95	0.96	1.00	0.95	1.00			1.00	
Satd. Flow (prot)	1805	1626		1698	1728	1528	1682	1861			3562	
Flt Permitted	0.95	1.00		0.95	0.96	1.00	0.41	1.00			1.00	
Satd. Flow (perm)	1805	1626		1698	1728	1528	719	1861			3562	
Peak-hour factor, PHF	0.91	0.91	0.91	0.91	0.91	0.91	0.91	0.91	0.91	0.91	0.91	0.91
Adj. Flow (vph)	32	11	110	384	60	370	30	338	21	0	541	11
RTOR Reduction (vph)	0	97	0	0	0	279	0	3	0	0	2	0
Lane Group Flow (vph)	32	24	0	219	225	91	30	356	0	0	550	0
Confl. Peds. (#/hr)	10					10	6		19	19		6
Confl. Bikes (#/hr)						2						3
Heavy Vehicles (%)	0%	0%	1%	1%	0%	2%	7%	1%	0%	0%	1%	0%
Turn Type	Split			Split			Perm	Perm				
Protected Phases	8	8		4	4			6				2
Permitted Phases						4	6					
Actuated Green, G (s)	4.8	4.8		10.5	10.5	10.5	15.9	15.9				15.9
Effective Green, g (s)	5.3	5.3		11.0	11.0	11.0	16.4	16.4				16.4
Actuated g/C Ratio	0.12	0.12		0.25	0.25	0.25	0.37	0.37				0.37
Clearance Time (s)	4.5	4.5		4.5	4.5	4.5	4.5	4.5				4.5
Vehicle Extension (s)	2.5	2.5		2.5	2.5	2.5	5.0	5.0				5.0
Lane Grp Cap (vph)	214	193		418	425	376	264	683				1307
v/s Ratio Prot	c0.02	0.01		0.13	c0.13			c0.19				0.15
v/s Ratio Perm						0.06	0.04					
v/c Ratio	0.15	0.12		0.52	0.53	0.24	0.11	0.52				0.42
Uniform Delay, d1	17.7	17.6		14.6	14.6	13.5	9.3	11.1				10.6
Progression Factor	1.00	1.00		1.00	1.00	1.00	1.00	1.00				1.00
Incremental Delay, d2	0.2	0.2		0.9	0.9	0.2	0.4	1.4				0.5
Delay (s)	17.9	17.8		15.5	15.5	13.8	9.7	12.4				11.1
Level of Service	B	B		B	B	B	A	B				B
Approach Delay (s)		17.9			14.7			12.2				11.1
Approach LOS		B			B			B				B
Intersection Summary												
HCM Average Control Delay			13.4									B
HCM Volume to Capacity ratio			0.46									
Actuated Cycle Length (s)			44.7								12.0	
Intersection Capacity Utilization			56.1%									B
Analysis Period (min)			15									

c Critical Lane Group

HCM Unsignalized Intersection Capacity Analysis

9: Nyberg St & Site Entrance 3

4/15/2013



Movement	EBL	EBT	WBT	WBR	SBL	SBR
Lane Configurations	↔		↔↔			↔
Volume (veh/h)	28	0	658	40	0	82
Sign Control		Free	Free		Stop	
Grade		0%	0%		0%	
Peak Hour Factor	0.88	0.88	0.88	0.88	0.88	0.88
Hourly flow rate (vph)	32	0	748	45	0	93
Pedestrians					5	
Lane Width (ft)					12.0	
Walking Speed (ft/s)					4.0	
Percent Blockage					0	
Right turn flare (veh)						
Median type		None	None			
Median storage (veh)						
Upstream signal (ft)		243				
pX, platoon unblocked						
vC, conflicting volume	798				839	402
vC1, stage 1 conf vol						
vC2, stage 2 conf vol						
vCu, unblocked vol	798				839	402
tC, single (s)	4.1				6.8	6.9
tC, 2 stage (s)						
tF (s)	2.2				3.5	3.3
p0 queue free %	96				100	85
cM capacity (veh/h)	830				295	601
Direction, Lane #	EB 1	WB 1	WB 2	SB 1		
Volume Total	32	498	295	93		
Volume Left	32	0	0	0		
Volume Right	0	0	45	93		
cSH	830	1700	1700	601		
Volume to Capacity	0.04	0.29	0.17	0.15		
Queue Length 95th (ft)	3	0	0	14		
Control Delay (s)	9.5	0.0	0.0	12.1		
Lane LOS	A			B		
Approach Delay (s)	9.5	0.0		12.1		
Approach LOS				B		
Intersection Summary						
Average Delay			1.6			
Intersection Capacity Utilization			31.2%		ICU Level of Service	A
Analysis Period (min)			15			

HCM Signalized Intersection Capacity Analysis
 10: Tualatin Sherwood Rd & Site Entrance 4

4/15/2013

Movement	EBL	EBT	EBR	WBL	WBT	WBR	NBL	NBT	NBR	SBL	SBT	SBR
Lane Configurations												
Volume (vph)	30	1930	40	232	1725	72	36	10	236	182	24	44
Ideal Flow (vphpl)	1900	1900	1900	1900	1900	1900	1900	1900	1900	1900	1900	1900
Total Lost time (s)	4.5	6.0		4.5	6.0			5.0	4.5		5.0	5.0
Lane Util. Factor	1.00	*0.75		0.97	0.91			1.00	1.00		1.00	1.00
Frbp, ped/bikes	1.00	1.00		1.00	1.00			1.00	1.00		1.00	0.97
Flpb, ped/bikes	1.00	1.00		1.00	1.00			0.99	1.00		1.00	1.00
Frt	1.00	1.00		1.00	0.99			1.00	0.85		1.00	0.85
Flt Protected	0.95	1.00		0.95	1.00			0.96	1.00		0.96	1.00
Satd. Flow (prot)	1805	4100		3502	4957			1768	1599		1803	1565
Flt Permitted	0.95	1.00		0.95	1.00			0.54	1.00		0.72	1.00
Satd. Flow (perm)	1805	4100		3502	4957			1000	1599		1350	1565
Peak-hour factor, PHF	0.98	0.98	0.98	0.98	0.98	0.98	0.98	0.98	0.98	0.98	0.98	0.98
Adj. Flow (vph)	31	1969	41	237	1760	73	37	10	241	186	24	45
RTOR Reduction (vph)	0	1	0	0	3	0	0	0	0	0	0	37
Lane Group Flow (vph)	31	2009	0	237	1830	0	0	47	241	0	210	8
Confl. Peds. (#/hr)			2			8	15					15
Confl. Bikes (#/hr)					1			1		1		
Heavy Vehicles (%)	0%	4%	0%	0%	4%	0%	3%	0%	1%	1%	0%	0%
Turn Type	Prot			Prot			Perm		pm+ov	Perm		Perm
Protected Phases	5	2		1	6			8	1		4	
Permitted Phases							8		8	4		4
Actuated Green, G (s)	5.4	73.7		11.8	80.1			22.5	34.3		22.5	22.5
Effective Green, g (s)	5.9	74.2		12.3	80.6			23.0	35.3		23.0	23.0
Actuated g/C Ratio	0.05	0.59		0.10	0.64			0.18	0.28		0.18	0.18
Clearance Time (s)	5.0	6.5		5.0	6.5			5.5	5.0		5.5	5.5
Vehicle Extension (s)	2.5	4.0		2.5	4.0			2.5	2.5		2.5	2.5
Lane Grp Cap (vph)	85	2434		345	3196			184	452		248	288
v/s Ratio Prot	0.02	c0.49		c0.07	0.37				0.05			
v/s Ratio Perm								0.05	0.10		c0.16	0.01
v/c Ratio	0.36	0.83		0.69	0.57			0.26	0.53		0.85	0.03
Uniform Delay, d1	57.7	20.2		54.5	12.5			43.7	37.9		49.3	41.8
Progression Factor	0.75	0.48		1.00	0.97			1.00	1.00		1.00	1.00
Incremental Delay, d2	0.9	1.7		3.7	0.5			0.5	0.9		22.2	0.0
Delay (s)	44.1	11.5		58.4	12.7			44.2	38.8		71.5	41.9
Level of Service	D	B		E	B			D	D		E	D
Approach Delay (s)		12.0			17.9			39.7			66.3	
Approach LOS		B			B			D			E	

Intersection Summary

HCM Average Control Delay	19.3	HCM Level of Service	B
HCM Volume to Capacity ratio	0.81		
Actuated Cycle Length (s)	125.0	Sum of lost time (s)	15.5
Intersection Capacity Utilization	82.1%	ICU Level of Service	E
Analysis Period (min)	15		

c Critical Lane Group

HCM Unsignalized Intersection Capacity Analysis
 11: Tualatin Sherwood Rd & 75th Ave

4/15/2013

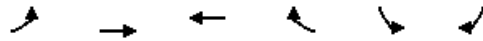













Movement	EBL	EBT	WBT	WBR	SBL	SBR	
Lane Configurations		↑↑↑	↑↑↑			↑	
Volume (veh/h)	0	2295	1995	35	0	4	
Sign Control		Free	Free		Stop		
Grade		0%	0%		0%		
Peak Hour Factor	0.99	0.99	0.99	0.99	0.99	0.99	
Hourly flow rate (vph)	0	2318	2015	35	0	4	
Pedestrians					1		
Lane Width (ft)					12.0		
Walking Speed (ft/s)					4.0		
Percent Blockage					0		
Right turn flare (veh)							
Median type		None	None				
Median storage (veh)							
Upstream signal (ft)		373	260				
pX, platoon unblocked	0.80				0.73	0.80	
vC, conflicting volume	2052				2807	690	
vC1, stage 1 conf vol							
vC2, stage 2 conf vol							
vCu, unblocked vol	1447				355	0	
tC, single (s)	4.1				6.8	7.0	
tC, 2 stage (s)							
tF (s)	2.2				3.5	3.3	
p0 queue free %	100				100	100	
cM capacity (veh/h)	380				450	866	
Direction, Lane #	EB 1	EB 2	EB 3	WB 1	WB 2	WB 3	SB 1
Volume Total	773	773	773	806	806	438	4
Volume Left	0	0	0	0	0	0	0
Volume Right	0	0	0	0	0	35	4
cSH	1700	1700	1700	1700	1700	1700	866
Volume to Capacity	0.45	0.45	0.45	0.47	0.47	0.26	0.00
Queue Length 95th (ft)	0	0	0	0	0	0	0
Control Delay (s)	0.0	0.0	0.0	0.0	0.0	0.0	9.2
Lane LOS							A
Approach Delay (s)	0.0			0.0			9.2
Approach LOS							A
Intersection Summary							
Average Delay			0.0				
Intersection Capacity Utilization			49.3%		ICU Level of Service		A
Analysis Period (min)			15				

HCM Signalized Intersection Capacity Analysis

12: Tualatin Sherwood Rd & I-5 SB Ramps













4/15/2013

												
Movement	EBL	EBT	EBR	WBL	WBT	WBR	NBL	NBT	NBR	SBL	SBT	SBR
Lane Configurations		↑↑↑	↑	↑	↑↑					↑	↑	↑↑
Volume (vph)	0	1514	835	123	1001	0	0	0	0	659	5	1060
Ideal Flow (vphpl)	1900	1900	1900	1900	1900	1900	1900	1900	1900	1900	1900	1900
Total Lost time (s)		5.5	5.5	5.5	5.5					5.5	5.5	5.5
Lane Util. Factor		*0.75	1.00	1.00	0.95					0.95	0.95	0.88
Frbp, ped/bikes		1.00	1.00	1.00	1.00					1.00	1.00	1.00
Flpb, ped/bikes		1.00	1.00	1.00	1.00					1.00	1.00	1.00
Frt		1.00	0.85	1.00	1.00					1.00	1.00	0.85
Flt Protected		1.00	1.00	0.95	1.00					0.95	0.95	1.00
Satd. Flow (prot)		4150	1568	1787	3471					1681	1682	2760
Flt Permitted		1.00	1.00	0.95	1.00					0.95	0.95	1.00
Satd. Flow (perm)		4150	1568	1787	3471					1681	1682	2760
Peak-hour factor, PHF	0.99	0.99	0.99	0.99	0.99	0.99	0.99	0.99	0.99	0.99	0.99	0.99
Adj. Flow (vph)	0	1529	843	124	1011	0	0	0	0	666	5	1071
RTOR Reduction (vph)	0	0	350	0	0	0	0	0	0	0	0	30
Lane Group Flow (vph)	0	1529	493	124	1011	0	0	0	0	333	338	1041
Confl. Bikes (#/hr)		1			2							
Heavy Vehicles (%)	0%	3%	3%	1%	4%	0%	0%	0%	0%	2%	20%	3%
Turn Type			Perm	Prot						Split		custom
Protected Phases		2		1	6					4	4	4.5
Permitted Phases			2									
Actuated Green, G (s)		58.2	58.2	11.1	53.3					37.7	37.7	59.7
Effective Green, g (s)		58.7	58.7	11.6	53.8					38.2	38.2	60.2
Actuated g/C Ratio		0.47	0.47	0.09	0.43					0.31	0.31	0.48
Clearance Time (s)		6.0	6.0	6.0	6.0					6.0	6.0	
Vehicle Extension (s)		6.1	6.1	2.3	6.1					2.3	2.3	
Lane Grp Cap (vph)		1949	736	166	1494					514	514	1329
v/s Ratio Prot		c0.37		0.07	c0.29					0.20	0.20	c0.38
v/s Ratio Perm			0.31									
v/c Ratio		0.78	0.67	0.75	0.68					0.65	0.66	0.78
Uniform Delay, d1		27.8	25.7	55.3	28.6					37.6	37.7	27.0
Progression Factor		0.75	0.55	1.27	0.62					1.00	1.00	1.00
Incremental Delay, d2		2.1	3.1	14.7	2.4					2.3	2.6	2.9
Delay (s)		22.9	17.3	85.1	20.1					39.9	40.3	29.9
Level of Service		C	B	F	C					D	D	C
Approach Delay (s)		20.9			27.2			0.0			33.8	
Approach LOS		C			C			A			C	
Intersection Summary												
HCM Average Control Delay			26.6			HCM Level of Service				C		
HCM Volume to Capacity ratio			0.81									
Actuated Cycle Length (s)			125.0			Sum of lost time (s)				16.5		
Intersection Capacity Utilization			90.7%			ICU Level of Service				E		
Analysis Period (min)			15									
c Critical Lane Group												

HCM Signalized Intersection Capacity Analysis

13: Tualatin Sherwood Rd & I-5 NB Ramps





















4/15/2013

												
Movement	EBL	EBT	EBR	WBL	WBT	WBR	NBL	NBT	NBR	SBL	SBT	SBR
Lane Configurations		↑↑	↑↑		↑↑	↑	↑	↑	↑			
Volume (vph)	0	1196	981	0	490	682	634	5	177	0	0	0
Ideal Flow (vphpl)	1900	1900	1900	1900	1900	1900	1900	1900	1900	1900	1900	1900
Total Lost time (s)		5.5	5.5		6.0	6.0	5.5	5.5	5.5			
Lane Util. Factor		0.95	0.88		0.95	1.00	0.95	0.95	1.00			
Frbp, ped/bikes		1.00	1.00		1.00	0.95	1.00	1.00	0.96			
Flpb, ped/bikes		1.00	1.00		1.00	1.00	1.00	1.00	1.00			
Frt		1.00	0.85		1.00	0.85	1.00	1.00	0.85			
Flt Protected		1.00	1.00		1.00	1.00	0.95	0.95	1.00			
Satd. Flow (prot)		3574	2760		3574	1502	1618	1620	1512			
Flt Permitted		1.00	1.00		1.00	1.00	0.95	0.95	1.00			
Satd. Flow (perm)		3574	2760		3574	1502	1618	1620	1512			
Peak-hour factor, PHF	0.95	0.95	0.95	0.95	0.95	0.95	0.95	0.95	0.95	0.95	0.95	0.95
Adj. Flow (vph)	0	1259	1033	0	516	718	667	5	186	0	0	0
RTOR Reduction (vph)	0	0	327	0	0	252	0	0	23	0	0	0
Lane Group Flow (vph)	0	1259	706	0	516	466	333	339	163	0	0	0
Confl. Peds. (#/hr)						16			17			
Confl. Bikes (#/hr)		1			5					1		
Heavy Vehicles (%)	0%	1%	3%	0%	1%	2%	6%	20%	2%	0%	0%	0%
Turn Type			Perm			Perm	Split		Perm			
Protected Phases		2			6		8	8				
Permitted Phases			2			6			8			
Actuated Green, G (s)		81.1	81.1		80.6	80.6	31.9	31.9	31.9			
Effective Green, g (s)		81.6	81.6		81.1	81.1	32.4	32.4	32.4			
Actuated g/C Ratio		0.65	0.65		0.65	0.65	0.26	0.26	0.26			
Clearance Time (s)		6.0	6.0		6.5	6.5	6.0	6.0	6.0			
Vehicle Extension (s)		6.1	6.1		4.2	4.2	2.3	2.3	2.3			
Lane Grp Cap (vph)		2333	1802		2319	974	419	420	392			
v/s Ratio Prot		c0.35			0.14		0.21	c0.21				
v/s Ratio Perm			0.26			0.31			0.11			
v/c Ratio		0.54	0.39		0.22	0.48	0.79	0.81	0.42			
Uniform Delay, d1		11.6	10.1		9.0	11.2	43.2	43.4	38.4			
Progression Factor		0.44	0.20		1.00	1.00	1.00	1.00	1.00			
Incremental Delay, d2		0.6	0.5		0.2	1.7	9.6	10.4	0.4			
Delay (s)		5.8	2.5		9.2	12.9	52.8	53.8	38.9			
Level of Service		A	A		A	B	D	D	D			
Approach Delay (s)		4.3			11.3			50.2			0.0	
Approach LOS		A			B			D			A	
Intersection Summary												
HCM Average Control Delay			15.2									B
HCM Volume to Capacity ratio			0.62									
Actuated Cycle Length (s)			125.0									11.0
Intersection Capacity Utilization			71.1%									C
Analysis Period (min)			15									

c Critical Lane Group

HCM Signalized Intersection Capacity Analysis
 14: Tualatin Sherwood Rd & Nyberg Woods

4/15/2013





















													
Movement	EBL	EBT	EBR	WBL	WBT	WBR	NBL	NBT	NBR	SBL	SBT	SBR	
Lane Configurations													
Volume (vph)	290	981	61	10	813	80	112	7	17	81	5	191	
Ideal Flow (vphpl)	1900	1900	1900	1900	1900	1900	1900	1900	1900	1900	1900	1900	
Total Lost time (s)	5.5	5.5		5.5	5.5			5.5	5.5		5.5	5.5	
Lane Util. Factor	0.97	0.95		1.00	0.95			1.00	1.00		1.00	1.00	
Frbp, ped/bikes	1.00	1.00		1.00	1.00			1.00	0.98		1.00	0.99	
Flpb, ped/bikes	1.00	1.00		1.00	1.00			1.00	1.00		1.00	1.00	
Frt	1.00	0.99		1.00	0.99			1.00	0.85		1.00	0.85	
Flt Protected	0.95	1.00		0.95	1.00			0.95	1.00		0.95	1.00	
Satd. Flow (prot)	3502	3503		1805	3523			1761	1590		1793	1592	
Flt Permitted	0.95	1.00		0.95	1.00			0.67	1.00		0.65	1.00	
Satd. Flow (perm)	3502	3503		1805	3523			1243	1590		1221	1592	
Peak-hour factor, PHF	0.96	0.96	0.96	0.96	0.96	0.96	0.96	0.96	0.96	0.96	0.96	0.96	
Adj. Flow (vph)	302	1022	64	10	847	83	117	7	18	84	5	199	
RTOR Reduction (vph)	0	3	0	0	7	0	0	0	15	0	0	165	
Lane Group Flow (vph)	302	1083	0	10	923	0	0	124	3	0	89	34	
Confl. Peds. (#/hr)	9		2	2		9	3		4	4		3	
Confl. Bikes (#/hr)		1			3								
Heavy Vehicles (%)	0%	2%	2%	0%	1%	0%	3%	0%	0%	1%	0%	0%	
Turn Type	Prot			Prot			Perm		Perm	Perm		Perm	
Protected Phases	5	2		1	6			8				4	
Permitted Phases							8		8	4		4	
Actuated Green, G (s)	9.1	33.8		0.7	25.4			10.3	10.3			10.3	
Effective Green, g (s)	9.6	34.3		1.2	25.9			10.8	10.8			10.8	
Actuated g/C Ratio	0.15	0.55		0.02	0.41			0.17	0.17			0.17	
Clearance Time (s)	6.0	6.0		6.0	6.0			6.0	6.0			6.0	
Vehicle Extension (s)	2.3	2.5		2.4	2.5			2.4	2.4			2.3	
Lane Grp Cap (vph)	535	1913		34	1453			214	273			210	
v/s Ratio Prot	c0.09	c0.31		0.01	c0.26								
v/s Ratio Perm								c0.10	0.00			0.07	
v/c Ratio	0.56	0.57		0.29	0.64			0.58	0.01			0.42	
Uniform Delay, d1	24.7	9.4		30.4	14.7			23.9	21.6			23.2	
Progression Factor	1.00	1.00		1.00	1.00			1.00	1.00			1.00	
Incremental Delay, d2	1.0	0.3		3.1	0.8			3.0	0.0			0.8	
Delay (s)	25.7	9.7		33.5	15.5			26.9	21.6			24.0	
Level of Service	C	A		C	B			C	C			C	
Approach Delay (s)		13.2			15.7			26.2				22.7	
Approach LOS		B			B			C				C	

Intersection Summary		
HCM Average Control Delay	15.7	HCM Level of Service B
HCM Volume to Capacity ratio	0.70	
Actuated Cycle Length (s)	62.8	Sum of lost time (s) 22.0
Intersection Capacity Utilization	61.0%	ICU Level of Service B
Analysis Period (min)	15	

c Critical Lane Group



























HCM Signalized Intersection Capacity Analysis
 15: SW Nyberg St & SW Nyberg St

4/15/2013

												
Movement	EBL	EBT	EBR	WBL	WBT	WBR	NBL	NBT	NBR	SBL	SBT	SBR
Lane Configurations												
Volume (vph)	217	927	26	24	759	16	17	9	45	5	7	135
Ideal Flow (vphpl)	1900	1900	1900	1900	1900	1900	1900	1900	1900	1900	1900	1900
Total Lost time (s)	4.8	4.8		4.8	4.8			5.6	5.6		5.3	4.8
Lane Util. Factor	1.00	1.00		1.00	0.95			1.00	1.00		1.00	1.00
Frpb, ped/bikes	1.00	1.00		1.00	1.00			1.00	0.95		1.00	1.00
Flpb, ped/bikes	1.00	1.00		1.00	1.00			1.00	1.00		1.00	1.00
Frt	1.00	1.00		1.00	1.00			1.00	0.85		1.00	0.85
Flt Protected	0.95	1.00		0.95	1.00			0.97	1.00		0.98	1.00
Satd. Flow (prot)	1805	1854		1805	3561			1803	1527		1848	1609
Flt Permitted	0.95	1.00		0.95	1.00			0.97	1.00		0.69	1.00
Satd. Flow (perm)	1805	1854		1805	3561			1803	1527		1304	1609
Peak-hour factor, PHF	0.96	0.96	0.96	0.96	0.96	0.96	0.96	0.96	0.96	0.96	0.96	0.96
Adj. Flow (vph)	226	966	27	25	791	17	18	9	47	5	7	141
RTOR Reduction (vph)	0	0	0	0	1	0	0	0	44	0	0	113
Lane Group Flow (vph)	226	993	0	25	807	0	0	27	3	0	12	28
Confl. Peds. (#/hr)	9		2	2		9	3		4	4		3
Heavy Vehicles (%)	0%	2%	2%	0%	1%	0%	3%	0%	0%	1%	0%	0%
Turn Type	Prot			Prot			Split		Perm	Perm		pm+ov
Protected Phases	5	2		1	6		8	8			4	5
Permitted Phases									8	4		4
Actuated Green, G (s)	11.5	48.9		1.7	39.1			4.1	4.1		3.6	15.1
Effective Green, g (s)	12.0	49.4		2.2	39.6			4.6	4.6		4.1	16.1
Actuated g/C Ratio	0.15	0.61		0.03	0.49			0.06	0.06		0.05	0.20
Clearance Time (s)	5.3	5.3		5.3	5.3			6.1	6.1		5.8	5.3
Vehicle Extension (s)	2.5	3.0		1.0	3.0			1.0	1.0		2.0	2.5
Lane Grp Cap (vph)	268	1134		49	1745			103	87		66	321
v/s Ratio Prot	c0.13	c0.54		0.01	0.23			c0.01				0.01
v/s Ratio Perm									0.00		c0.01	0.00
v/c Ratio	0.84	0.88		0.51	0.46			0.26	0.03		0.18	0.09
Uniform Delay, d1	33.5	13.1		38.8	13.6			36.5	36.0		36.7	26.4
Progression Factor	1.00	1.00		1.00	1.00			1.00	1.00		1.00	1.00
Incremental Delay, d2	20.5	7.8		3.7	0.2			0.5	0.1		0.5	0.1
Delay (s)	54.0	20.9		42.5	13.8			37.0	36.0		37.2	26.4
Level of Service	D	C		D	B			D	D		D	C
Approach Delay (s)		27.0			14.6			36.4			27.3	
Approach LOS		C			B			D			C	
Intersection Summary												
HCM Average Control Delay			22.8			HCM Level of Service			C			
HCM Volume to Capacity ratio			0.81									
Actuated Cycle Length (s)			80.8			Sum of lost time (s)		20.5				
Intersection Capacity Utilization			75.9%			ICU Level of Service		D				
Analysis Period (min)			15									
c Critical Lane Group												

























HCM Signalized Intersection Capacity Analysis
 16: SW Tualatin Sherwood Rd & SW Boones Ferry Rd

4/15/2013

												
Movement	EBL	EBT	EBR	WBL	WBT	WBR	NBL	NBT	NBR	SBL	SBT	SBR
Lane Configurations		 		 	 						 	
Volume (vph)	103	1014	138	224	1083	56	171	268	159	297	345	133
Ideal Flow (vphpl)	1900	1900	1900	1900	1900	1900	1900	1900	1900	1900	1900	1900
Total Lost time (s)	4.5	5.5		4.5	5.5		4.5	5.0	4.5	4.5	5.0	
Lane Util. Factor	1.00	0.95		0.97	0.95		1.00	1.00	1.00	1.00	0.95	
Frpb, ped/bikes	1.00	1.00		1.00	1.00		1.00	1.00	0.98	1.00	0.99	
Flpb, ped/bikes	1.00	1.00		1.00	1.00		1.00	1.00	1.00	1.00	1.00	
Frt	1.00	0.98		1.00	0.99		1.00	1.00	0.85	1.00	0.96	
Flt Protected	0.95	1.00		0.95	1.00		0.95	1.00	1.00	0.95	1.00	
Satd. Flow (prot)	1703	3319		3502	3338		1733	1810	1542	1761	3313	
Flt Permitted	0.95	1.00		0.95	1.00		0.40	1.00	1.00	0.59	1.00	
Satd. Flow (perm)	1703	3319		3502	3338		737	1810	1542	1099	3313	
Peak-hour factor, PHF	0.99	0.99	0.99	0.99	0.99	0.99	0.99	0.99	0.99	0.99	0.99	0.99
Adj. Flow (vph)	104	1024	139	226	1094	57	173	271	161	300	348	134
RTOR Reduction (vph)	0	8	0	0	3	0	0	0	54	0	34	0
Lane Group Flow (vph)	104	1155	0	226	1148	0	173	271	107	300	448	0
Confl. Peds. (#/hr)			7			15	7		8	8		7
Heavy Vehicles (%)	6%	7%	3%	0%	7%	6%	4%	5%	3%	2%	4%	3%
Turn Type	Prot			Prot			pm+pt		pm+ov		pm+pt	
Protected Phases	5	2		1	6		3	8	1	7	4	
Permitted Phases							8		8	4		
Actuated Green, G (s)	10.0	55.9		9.4	55.3		21.3	21.3	30.7	27.3	26.8	
Effective Green, g (s)	10.5	56.4		9.9	55.8		21.8	21.8	31.7	27.8	27.3	
Actuated g/C Ratio	0.08	0.45		0.08	0.45		0.17	0.17	0.25	0.22	0.22	
Clearance Time (s)	5.0	6.0		5.0	6.0		5.0	5.5	5.0	5.0	5.5	
Vehicle Extension (s)	2.0	3.5		2.0	3.5		2.0	2.0	2.0	2.0	2.0	
Lane Grp Cap (vph)	143	1498		277	1490		223	316	391	337	724	
v/s Ratio Prot	0.06	c0.35		0.06	c0.34		0.07	c0.15	0.02	c0.12	0.14	
v/s Ratio Perm							0.06		0.05	c0.07		
v/c Ratio	0.73	0.77		0.82	0.77		0.78	0.86	0.27	0.89	0.62	
Uniform Delay, d1	55.9	28.9		56.7	29.2		47.5	50.1	37.4	45.8	44.1	
Progression Factor	1.00	1.00		1.26	0.41		1.00	1.00	1.00	1.00	1.00	
Incremental Delay, d2	14.4	3.9		10.4	2.4		14.2	19.3	0.1	23.5	1.1	
Delay (s)	70.3	32.8		82.0	14.3		61.7	69.3	37.5	69.4	45.3	
Level of Service	E	C		F	B		E	E	D	E	D	
Approach Delay (s)		35.9			25.4			58.7			54.5	
Approach LOS		D			C			E			D	
Intersection Summary												
HCM Average Control Delay			39.3			HCM Level of Service				D		
HCM Volume to Capacity ratio			0.85									
Actuated Cycle Length (s)			125.0			Sum of lost time (s)			20.5			
Intersection Capacity Utilization			87.3%			ICU Level of Service			E			
Analysis Period (min)			15									
c Critical Lane Group												





















HCM Signalized Intersection Capacity Analysis
 17: Tualatin Sherwood Rd & Martinazzi Ave

4/15/2013

													
Movement	EBL	EBT	EBR	WBL	WBT	WBR	NBL	NBT	NBR	SBL	SBT	SBR	
Lane Configurations		 			 						 		
Volume (vph)	52	1484	83	0	1110	0	95	302	323	194	663	88	
Ideal Flow (vphpl)	1900	1900	1900	1900	1900	1900	1900	1900	1900	1900	1900	1900	
Total Lost time (s)	4.5	5.5			5.5		4.5	5.5	5.5	4.5	5.5		
Lane Util. Factor	1.00	*0.95			0.95		1.00	1.00	1.00	1.00	0.95		
Frpb, ped/bikes	1.00	1.00			1.00		1.00	1.00	0.98	1.00	1.00		
Flpb, ped/bikes	1.00	1.00			1.00		1.00	1.00	1.00	1.00	1.00		
Fr t	1.00	0.99			1.00		1.00	1.00	0.85	1.00	0.98		
Fl t Protected	0.95	1.00			1.00		0.95	1.00	1.00	0.95	1.00		
Satd. Flow (prot)	1719	3447			3438		1770	1863	1574	1787	3497		
Fl t Permitted	0.95	1.00			1.00		0.95	1.00	1.00	0.95	1.00		
Satd. Flow (perm)	1719	3447			3438		1770	1863	1574	1787	3497		
Peak-hour factor, PHF	0.94	0.94	0.94	0.94	0.94	0.94	0.94	0.94	0.94	0.94	0.94	0.94	
Adj. Flow (vph)	55	1579	88	0	1181	0	101	321	344	206	705	94	
RTOR Reduction (vph)	0	3	0	0	0	0	0	0	82	0	9	0	
Lane Group Flow (vph)	55	1664	0	0	1181	0	101	321	262	206	790	0	
Confl. Peds. (#/hr)			4				2		3			16	
Heavy Vehicles (%)	5%	4%	0%	0%	5%	0%	2%	2%	1%	1%	1%	1%	
Turn Type	Prot							Prot		Perm		Prot	
Protected Phases	5	2			6		3	8			7	4	
Permitted Phases									8				
Actuated Green, G (s)	7.8	65.5			52.7		10.0	23.5	23.5	19.0	32.5		
Effective Green, g (s)	8.3	66.0			53.2		10.5	24.0	24.0	19.5	33.0		
Actuated g/C Ratio	0.07	0.53			0.43		0.08	0.19	0.19	0.16	0.26		
Clearance Time (s)	5.0	6.0			6.0		5.0	6.0	6.0	5.0	6.0		
Vehicle Extension (s)	2.0	3.5			3.5		3.0	2.0	2.0	3.0	2.0		
Lane Grp Cap (vph)	114	1820			1463		149	358	302	279	923		
v/s Ratio Prot	0.03	c0.48			0.34		0.06	c0.17		0.12	c0.23		
v/s Ratio Perm									0.17				
v/c Ratio	0.48	0.91			0.81		0.68	0.90	0.87	0.74	0.86		
Uniform Delay, d1	56.3	26.9			31.4		55.6	49.3	49.0	50.3	43.7		
Progression Factor	0.74	1.13			0.56		1.00	1.00	1.00	1.00	1.00		
Incremental Delay, d2	0.9	6.8			4.3		11.6	23.3	21.6	9.8	7.6		
Delay (s)	42.5	37.2			21.9		67.2	72.6	70.6	60.1	51.3		
Level of Service	D	D			C		E	E	E	E	D		
Approach Delay (s)	37.4			21.9			71.0			53.1			
Approach LOS	D			C			E			D			
Intersection Summary													
HCM Average Control Delay	42.4			HCM Level of Service				D					
HCM Volume to Capacity ratio	0.88												
Actuated Cycle Length (s)	125.0			Sum of lost time (s)				11.0					
Intersection Capacity Utilization	88.0%			ICU Level of Service				E					
Analysis Period (min)	15												
c Critical Lane Group													





















HCM Signalized Intersection Capacity Analysis
 18: SW Borland Rd & SW 65th Ave

4/15/2013

													
Movement	EBL	EBT	EBR	WBL	WBT	WBR	NBL	NBT	NBR	SBL	SBT	SBR	
Lane Configurations													
Volume (vph)	23	23	10	240	0	234	2	334	359	423	474	10	
Ideal Flow (vphpl)	1900	1900	1900	1900	1900	1900	1900	1900	1900	1900	1900	1900	
Total Lost time (s)		5.6			5.3	5.6	4.8	4.8		4.8	4.8		
Lane Util. Factor		1.00			1.00	1.00	1.00	1.00		1.00	1.00		
Frbp, ped/bikes		0.99			1.00	0.90	1.00	0.98		1.00	1.00		
Flpb, ped/bikes		1.00			1.00	1.00	1.00	1.00		1.00	1.00		
Frt		0.98			1.00	0.85	1.00	0.92		1.00	1.00		
Flt Protected		0.98			0.95	1.00	0.95	1.00		0.95	1.00		
Satd. Flow (prot)		1786			1805	1457	1748	1721		1787	1893		
Flt Permitted		0.98			0.95	1.00	0.48	1.00		0.09	1.00		
Satd. Flow (perm)		1786			1805	1457	880	1721		165	1893		
Peak-hour factor, PHF	0.96	0.96	0.96	0.96	0.96	0.96	0.96	0.96	0.96	0.96	0.96	0.96	
Adj. Flow (vph)	24	24	10	250	0	244	2	348	374	441	494	10	
RTOR Reduction (vph)	0	6	0	0	0	230	0	24	0	0	0	0	
Lane Group Flow (vph)	0	52	0	0	250	14	2	698	0	441	504	0	
Confl. Peds. (#/hr)	9		2	2		9	3		4	4		3	
Heavy Vehicles (%)	0%	2%	2%	0%	1%	0%	3%	0%	0%	1%	0%	0%	
Turn Type	Split			Split		custom	pm+pt				pm+pt		
Protected Phases	8	8		4	4		1	6		5	2		
Permitted Phases						8	6			2			
Actuated Green, G (s)		7.6			20.0	7.6	64.4	63.4		98.7	92.4		
Effective Green, g (s)		8.1			20.5	8.1	65.4	63.9		99.2	92.9		
Actuated g/C Ratio		0.06			0.14	0.06	0.46	0.45		0.69	0.65		
Clearance Time (s)		6.1			5.8	6.1	5.3	5.3		5.3	5.3		
Vehicle Extension (s)		1.0			2.0	1.0	1.0	3.0		2.5	0.2		
Lane Grp Cap (vph)		101			258	82	410	766		459	1226		
v/s Ratio Prot		c0.03			c0.14		0.00	0.41		c0.20	0.27		
v/s Ratio Perm						0.01	0.00			c0.46			
v/c Ratio		0.52			0.97	0.17	0.00	0.91		0.96	0.41		
Uniform Delay, d1		65.8			61.2	64.5	21.3	37.1		43.9	12.2		
Progression Factor		1.00			1.00	1.00	1.00	1.00		1.00	1.00		
Incremental Delay, d2		1.9			46.6	0.4	0.0	15.0		32.0	0.1		
Delay (s)		67.7			107.8	64.8	21.3	52.1		75.9	12.2		
Level of Service		E			F	E	C	D		E	B		
Approach Delay (s)		67.7			86.6			52.0			41.9		
Approach LOS		E			F			D			D		
Intersection Summary													
HCM Average Control Delay			55.8									HCM Level of Service	E
HCM Volume to Capacity ratio			0.92										
Actuated Cycle Length (s)			143.5									Sum of lost time (s)	15.7
Intersection Capacity Utilization			95.6%									ICU Level of Service	F
Analysis Period (min)			15										
c Critical Lane Group													

HCM Signalized Intersection Capacity Analysis
 19: SW Sagert St & SW Boones Ferry Rd

4/15/2013

												
Movement	EBL	EBT	EBR	WBL	WBT	WBR	NBL	NBT	NBR	SBL	SBT	SBR
Lane Configurations												
Volume (vph)	42	107	13	166	112	64	16	476	218	65	561	75
Ideal Flow (vphpl)	1900	1900	1900	1900	1900	1900	1900	1900	1900	1900	1900	1900
Total Lost time (s)	3.5	3.5		3.5	3.5		3.5	4.0		3.5	4.0	
Lane Util. Factor	1.00	1.00		1.00	1.00		1.00	1.00		1.00	1.00	
Frbp, ped/bikes	1.00	1.00		1.00	0.98		1.00	0.99		1.00	1.00	
Flpb, ped/bikes	0.99	1.00		1.00	1.00		1.00	1.00		1.00	1.00	
Frt	1.00	0.98		1.00	0.95		1.00	0.95		1.00	0.98	
Flt Protected	0.95	1.00		0.95	1.00		0.95	1.00		0.95	1.00	
Satd. Flow (prot)	1781	1827		1780	1733		1768	1787		1804	1860	
Flt Permitted	0.64	1.00		0.44	1.00		0.26	1.00		0.17	1.00	
Satd. Flow (perm)	1202	1827		825	1733		482	1787		331	1860	
Peak-hour factor, PHF	0.95	0.95	0.95	0.95	0.95	0.95	0.95	0.95	0.95	0.95	0.95	0.95
Adj. Flow (vph)	44	113	14	175	118	67	17	501	229	68	591	79
RTOR Reduction (vph)	0	4	0	0	18	0	0	11	0	0	3	0
Lane Group Flow (vph)	44	123	0	175	167	0	17	719	0	68	667	0
Confl. Peds. (#/hr)	15		7	7		15	7		8	8		7
Heavy Vehicles (%)	0%	2%	1%	1%	3%	0%	2%	0%	1%	0%	0%	0%
Turn Type	pm+pt		pm+pt			pm+pt			pm+pt			
Protected Phases	7	4		3	8		5	2		1	6	
Permitted Phases	4			8			2			6		
Actuated Green, G (s)	15.3	12.3		25.7	18.7		47.0	45.5		51.6	47.8	
Effective Green, g (s)	16.3	12.8		26.2	19.2		48.0	46.0		52.6	48.3	
Actuated g/C Ratio	0.19	0.15		0.30	0.22		0.55	0.53		0.60	0.55	
Clearance Time (s)	4.0	4.0		4.0	4.0		4.0	4.5		4.0	4.5	
Vehicle Extension (s)	2.2	2.2		2.2	2.2		2.2	5.0		2.2	5.0	
Lane Grp Cap (vph)	247	267		355	380		294	939		271	1027	
v/s Ratio Prot	0.01	0.07		c0.06	0.10		0.00	c0.40		c0.01	0.36	
v/s Ratio Perm	0.03			c0.09			0.03			0.14		
v/c Ratio	0.18	0.46		0.49	0.44		0.06	0.77		0.25	0.65	
Uniform Delay, d1	29.7	34.2		24.0	29.5		10.7	16.5		11.7	13.7	
Progression Factor	1.00	1.00		1.00	1.00		1.00	1.00		1.00	1.00	
Incremental Delay, d2	0.2	0.6		0.6	0.4		0.0	4.4		0.2	1.9	
Delay (s)	29.9	34.8		24.6	29.9		10.7	20.9		11.9	15.6	
Level of Service	C	C		C	C		B	C		B	B	
Approach Delay (s)		33.6			27.3			20.7			15.3	
Approach LOS		C			C			C			B	
Intersection Summary												
HCM Average Control Delay			21.0			HCM Level of Service				C		
HCM Volume to Capacity ratio			0.67									
Actuated Cycle Length (s)			87.5			Sum of lost time (s)			14.5			
Intersection Capacity Utilization			73.9%			ICU Level of Service				D		
Analysis Period (min)			15									
c Critical Lane Group												

Phone:
E-Mail:

Fax:

ALL-WAY STOP CONTROL (AWSC) ANALYSIS

Analyst:
Agency/Co.:
Date Performed: 4/16/2013
Analysis Time Period: Weekday PM
Intersection: Sagert/Martinazzi
Jurisdiction:
Units: U. S. Customary
Analysis Year: Background
Project ID:
East/West Street: Sagert
North/South Street: Martinazzi

Worksheet 2 - Volume Adjustments and Site Characteristics

	Eastbound			Westbound			Northbound			Southbound		
	L	T	R	L	T	R	L	T	R	L	T	R
Volume	117	233	12	90	195	164	2	180	76	207	296	
% Thrus Left Lane												

	Eastbound		Westbound		Northbound		Southbound	
	L1	L2	L1	L2	L1	L2	L1	L2
Configuration	L	TR	L	TR	L	TR	L	TR
PHF	0.90	0.90	0.90	0.90	0.90	0.90	0.90	0.90
Flow Rate	130	271	100	398	2	284	230	585
% Heavy Veh	1	1	1	1	1	1	1	1
No. Lanes		2		2		2		2
Opposing-Lanes		2		2		2		2
Conflicting-lanes		2		2		2		2
Geometry group		5		5		5		5
Duration, T	0.25 hrs.							

Worksheet 3 - Saturation Headway Adjustment Worksheet

	Eastbound		Westbound		Northbound		Southbound	
	L1	L2	L1	L2	L1	L2	L1	L2
Flow Rates:								
Total in Lane	130	271	100	398	2	284	230	585
Left-Turn	130	0	100	0	2	0	230	0
Right-Turn	0	13	0	182	0	84	0	257
Prop. Left-Turns	1.0	0.0	1.0	0.0	1.0	0.0	1.0	0.0
Prop. Right-Turns	0.0	0.0	0.0	0.5	0.0	0.3	0.0	0.4
Prop. Heavy Vehicle	0.0	0.0	0.0	0.0	0.0	0.0	0.0	0.0
Geometry Group		5		5		5		5
Adjustments Exhibit 17-33:								
hLT-adj		0.5		0.5		0.5		0.5

hRT-adj	-0.7	-0.7	-0.7	-0.7
hHV-adj	1.7	1.7	1.7	1.7
hadj, computed	0.5	-0.0	0.5	-0.3

Worksheet 4 - Departure Headway and Service Time

	Eastbound		Westbound		Northbound		Southbound	
	L1	L2	L1	L2	L1	L2	L1	L2
Flow rate	130	271	100	398	2	284	230	585
hd, initial value	3.20	3.20	3.20	3.20	3.20	3.20	3.20	3.20
x, initial	0.12	0.24	0.09	0.35	0.00	0.25	0.20	0.52
hd, final value	9.23	8.70	9.00	8.18	9.42	8.71	8.80	7.99
x, final value	0.33	0.65	0.25	0.90	0.01	0.69	0.56	1.30
Move-up time, m		2.3		2.3		2.3		2.3
Service Time	6.9	6.4	6.7	5.9	7.1	6.4	6.5	5.7

Worksheet 5 - Capacity and Level of Service

	Eastbound		Westbound		Northbound		Southbound	
	L1	L2	L1	L2	L1	L2	L1	L2
Flow Rate	130	271	100	398	2	284	230	585
Service Time	6.9	6.4	6.7	5.9	7.1	6.4	6.5	5.7
Utilization, x	0.33	0.65	0.25	0.90	0.01	0.69	0.56	1.30
Dep. headway, hd	9.23	8.70	9.00	8.18	9.42	8.71	8.80	7.99
Capacity	380	408	350	439	252	406	407	585
Delay	16.48	26.44	14.68	51.04	12.17	28.50	22.21	173.73
LOS	C	D	B	F	B	D	C	F
Approach:								
Delay		23.21		43.74		28.38		130.97
LOS		C		E		D		F
Intersection Delay	72.97							
					Intersection LOS	F		

Phone:
E-Mail:

Fax:

ALL-WAY STOP CONTROL (AWSC) ANALYSIS

Analyst:
Agency/Co.:
Date Performed: 4/16/2013
Analysis Time Period: Weekday PM
Intersection: Sagert/65th
Jurisdiction:
Units: U. S. Customary
Analysis Year: Background
Project ID:
East/West Street: Sagert
North/South Street: 65th

Worksheet 2 - Volume Adjustments and Site Characteristics

	Eastbound			Westbound			Northbound			Southbound		
	L	T	R	L	T	R	L	T	R	L	T	R
Volume	401	2	135	2	7	6	58	288	3	3	335	386
% Thrus Left Lane												

	Eastbound		Westbound		Northbound		Southbound	
	L1	L2	L1	L2	L1	L2	L1	L2
Configuration	L	TR	L	TR	L	TR	L	TR
PHF	0.90	0.90	0.90	0.90	0.90	0.90	0.90	0.90
Flow Rate	445	152	2	13	64	323	3	800
% Heavy Veh	1	1	0	0	1	2	1	2
No. Lanes	2		2		2		2	
Opposing-Lanes	2		2		2		2	
Conflicting-lanes	2		2		2		2	
Geometry group	5		5		5		5	
Duration, T	0.25 hrs.							

Worksheet 3 - Saturation Headway Adjustment Worksheet

	Eastbound		Westbound		Northbound		Southbound	
	L1	L2	L1	L2	L1	L2	L1	L2
Flow Rates:								
Total in Lane	445	152	2	13	64	323	3	800
Left-Turn	445	0	2	0	64	0	3	0
Right-Turn	0	150	0	6	0	3	0	428
Prop. Left-Turns	1.0	0.0	1.0	0.0	1.0	0.0	1.0	0.0
Prop. Right-Turns	0.0	1.0	0.0	0.5	0.0	0.0	0.0	0.5
Prop. Heavy Vehicle	0.0	0.0	0.0	0.0	0.0	0.0	0.0	0.0
Geometry Group	5		5		5		5	
Adjustments Exhibit 17-33:								
hLT-adj	0.5		0.5		0.5		0.5	

hRT-adj	-0.7	-0.7	-0.7	-0.7
hHV-adj	1.7	1.7	1.7	1.7
hadj, computed	0.5	-0.7	0.5	-0.3

Worksheet 4 - Departure Headway and Service Time

	Eastbound		Westbound		Northbound		Southbound	
	L1	L2	L1	L2	L1	L2	L1	L2
Flow rate	445	152	2	13	64	323	3	800
hd, initial value	3.20	3.20	3.20	3.20	3.20	3.20	3.20	3.20
x, initial	0.40	0.14	0.00	0.01	0.06	0.29	0.00	0.71
hd, final value	7.73	6.54	9.23	8.40	8.00	7.51	7.77	6.91
x, final value	0.96	0.28	0.01	0.03	0.14	0.67	0.01	1.54
Move-up time, m		2.3		2.3		2.3		2.3
Service Time	5.4	4.2	6.9	6.1	5.7	5.2	5.5	4.6

Worksheet 5 - Capacity and Level of Service

	Eastbound		Westbound		Northbound		Southbound	
	L1	L2	L1	L2	L1	L2	L1	L2
Flow Rate	445	152	2	13	64	323	3	800
Service Time	5.4	4.2	6.9	6.1	5.7	5.2	5.5	4.6
Utilization, x	0.96	0.28	0.01	0.03	0.14	0.67	0.01	1.54
Dep. headway, hd	7.73	6.54	9.23	8.40	8.00	7.51	7.77	6.91
Capacity	466	402	252	263	314	475	253	800
Delay	58.85	11.71	11.98	11.37	12.02	24.33	10.52	269.49
LOS	F	B	B	B	B	C	B	F
Approach:								
Delay		46.85		11.45		22.29		268.52
LOS		E		B		C		F
Intersection Delay	140.06							

Intersection: 12: Tualatin Sherwood Rd & I-5 SB Ramps

Movement	EB	EB	EB	EB	WB	WB	WB	SB	SB	SB	SB
Directions Served	T	T	T	R	L	T	T	L	LT	R	R
Maximum Queue (ft)	284	274	264	152	433	501	537	275	719	625	476
Average Queue (ft)	172	189	171	14	133	250	270	190	349	304	173
95th Queue (ft)	265	285	246	89	324	483	512	304	664	552	387
Link Distance (ft)	181	181	181	181	635	635	635		1148	1148	
Upstream Blk Time (%)	6	8	8	0	1	2	2		0	0	
Queuing Penalty (veh)	32	48	45	1	2	7	7		0	0	
Storage Bay Dist (ft)								200			700
Storage Blk Time (%)								7	25	1	0
Queuing Penalty (veh)								22	82	4	0

Intersection: 13: Tualatin Sherwood Rd & I-5 NB Ramps

Movement	EB	EB	WB	WB	WB	NB	NB	NB	B33
Directions Served	T	T	T	T	R	L	LT	R	T
Maximum Queue (ft)	469	436	198	301	225	356	441	299	54
Average Queue (ft)	186	174	82	101	14	222	238	102	10
95th Queue (ft)	384	364	166	218	103	336	401	225	93
Link Distance (ft)	635	635	468	468			463		253
Upstream Blk Time (%)				0			2		2
Queuing Penalty (veh)				1			0		0
Storage Bay Dist (ft)					150	300		225	
Storage Blk Time (%)				3	0	3	10	0	
Queuing Penalty (veh)				18	0	15	51	2	

HCM Signalized Intersection Capacity Analysis

3: SW Boones Ferry Road & SW Martinazzi Ave

4/17/2013

	→	↘	↙	←	↖	↗
Movement	EBT	EBR	WBL	WBT	NBL	NBR
Lane Configurations	↑	↗	↘	↑	↘	↗
Volume (vph)	417	125	258	429	185	304
Ideal Flow (vphpl)	1900	1900	1900	1900	1900	1900
Total Lost time (s)	4.5	4.5	4.5	4.5	4.5	4.5
Lane Util. Factor	1.00	1.00	1.00	1.00	1.00	1.00
Frbp, ped/bikes	1.00	1.00	1.00	1.00	1.00	0.99
Flpb, ped/bikes	1.00	1.00	1.00	1.00	1.00	1.00
Frt	1.00	0.85	1.00	1.00	1.00	0.85
Flt Protected	1.00	1.00	0.95	1.00	0.95	1.00
Satd. Flow (prot)	1863	1599	1787	1845	1770	1581
Flt Permitted	1.00	1.00	0.95	1.00	0.95	1.00
Satd. Flow (perm)	1863	1599	1787	1845	1770	1581
Peak-hour factor, PHF	0.95	0.95	0.95	0.95	0.95	0.95
Adj. Flow (vph)	439	132	272	452	195	320
RTOR Reduction (vph)	0	90	0	0	0	93
Lane Group Flow (vph)	439	42	272	452	195	227
Confl. Peds. (#/hr)		11	11		1	3
Confl. Bikes (#/hr)	4		2	10	1	
Heavy Vehicles (%)	2%	1%	1%	3%	2%	1%
Turn Type		Prot	Prot			pm+ov
Protected Phases	2	2	1	6	8	1
Permitted Phases					8	8
Actuated Green, G (s)	17.1	17.1	12.7	34.8	11.0	23.7
Effective Green, g (s)	17.6	17.6	13.2	35.3	11.5	24.7
Actuated g/C Ratio	0.32	0.32	0.24	0.63	0.21	0.44
Clearance Time (s)	5.0	5.0	5.0	5.0	5.0	5.0
Vehicle Extension (s)	3.0	3.0	3.0	3.0	3.0	3.0
Lane Grp Cap (vph)	588	504	423	1167	365	827
v/s Ratio Prot	c0.24	0.03	c0.15	0.25	c0.11	0.06
v/s Ratio Perm						0.08
v/c Ratio	0.75	0.08	0.64	0.39	0.53	0.27
Uniform Delay, d1	17.1	13.4	19.2	5.0	19.8	9.9
Progression Factor	1.00	1.00	1.00	1.00	1.00	1.00
Incremental Delay, d2	5.1	0.1	3.3	0.2	1.5	0.2
Delay (s)	22.2	13.5	22.5	5.2	21.3	10.0
Level of Service	C	B	C	A	C	B
Approach Delay (s)	20.2			11.7	14.3	
Approach LOS	C			B	B	

Intersection Summary

HCM Average Control Delay	15.1	HCM Level of Service	B
HCM Volume to Capacity ratio	0.66		
Actuated Cycle Length (s)	55.8	Sum of lost time (s)	13.5
Intersection Capacity Utilization	58.4%	ICU Level of Service	B
Analysis Period (min)	15		

c Critical Lane Group

HCM Unsignalized Intersection Capacity Analysis

4: Site Entrance 1 & Martinazzi Ave

4/17/2013

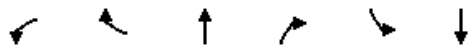

Movement	WBL	WBR	NBT	NBR	SBL	SBT
Lane Configurations	↶	↷	↷		↶	↷
Volume (veh/h)	46	80	408	60	110	269
Sign Control	Stop		Free			Free
Grade	0%		0%			0%
Peak Hour Factor	0.92	0.92	0.92	0.92	0.92	0.92
Hourly flow rate (vph)	50	87	443	65	120	292
Pedestrians	13					6
Lane Width (ft)	12.0					12.0
Walking Speed (ft/s)	4.0					4.0
Percent Blockage	1					1
Right turn flare (veh)						
Median type			None			TWLTL
Median storage (veh)						2
Upstream signal (ft)			428			355
pX, platoon unblocked	0.97	0.97			0.97	
vC, conflicting volume	1021	495			522	
vC1, stage 1 conf vol	489					
vC2, stage 2 conf vol	532					
vCu, unblocked vol	1007	467			494	
tC, single (s)	6.4	6.2			4.1	
tC, 2 stage (s)	5.4					
tF (s)	3.5	3.3			2.2	
p0 queue free %	89	85			88	
cM capacity (veh/h)	441	574			1039	
Direction, Lane #	WB 1	WB 2	NB 1	SB 1	SB 2	
Volume Total	50	87	509	120	292	
Volume Left	50	0	0	120	0	
Volume Right	0	87	65	0	0	
cSH	441	574	1700	1039	1700	
Volume to Capacity	0.11	0.15	0.30	0.12	0.17	
Queue Length 95th (ft)	10	14	0	10	0	
Control Delay (s)	14.2	12.4	0.0	8.9	0.0	
Lane LOS	B	B		A		
Approach Delay (s)	13.1		0.0	2.6		
Approach LOS	B					
Intersection Summary						
Average Delay			2.7			
Intersection Capacity Utilization			46.5%		ICU Level of Service	A
Analysis Period (min)			15			

HCM Unsignalized Intersection Capacity Analysis

5: Seneca St & Martinazzi Ave

4/17/2013



Movement	EBL	EBR	NBL	NBT	SBT	SBR
Lane Configurations						
Volume (veh/h)	37	45	81	432	271	44
Sign Control	Stop			Free	Free	
Grade	0%			0%	0%	
Peak Hour Factor	0.91	0.91	0.91	0.91	0.91	0.91
Hourly flow rate (vph)	41	49	89	475	298	48
Pedestrians	1			4	10	
Lane Width (ft)	12.0			12.0	12.0	
Walking Speed (ft/s)	4.0			4.0	4.0	
Percent Blockage	0			0	1	
Right turn flare (veh)						
Median type				None	None	
Median storage (veh)						
Upstream signal (ft)				308	475	
pX, platoon unblocked	0.96					
vC, conflicting volume	986	327	347			
vC1, stage 1 conf vol						
vC2, stage 2 conf vol						
vCu, unblocked vol	962	327	347			
tC, single (s)	6.4	6.2	4.1			
tC, 2 stage (s)						
tF (s)	3.5	3.3	2.2			
p0 queue free %	84	93	93			
cM capacity (veh/h)	251	716	1222			
Direction, Lane #	EB 1	NB 1	NB 2	SB 1		
Volume Total	90	89	475	346		
Volume Left	41	89	0	0		
Volume Right	49	0	0	48		
cSH	391	1222	1700	1700		
Volume to Capacity	0.23	0.07	0.28	0.20		
Queue Length 95th (ft)	23	6	0	0		
Control Delay (s)	17.0	8.2	0.0	0.0		
Lane LOS	C	A				
Approach Delay (s)	17.0	1.3		0.0		
Approach LOS	C					
Intersection Summary						
Average Delay			2.3			
Intersection Capacity Utilization			37.5%	ICU Level of Service	A	
Analysis Period (min)			15			

HCM Unsignalized Intersection Capacity Analysis

6: Site Entrance 2 & Martinazzi Ave

4/17/2013

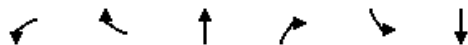

Movement	WBL	WBR	NBT	NBR	SBL	SBT
Lane Configurations	Y		T			T↑
Volume (veh/h)	5	25	489	9	3	314
Sign Control	Stop		Free			Free
Grade	0%		0%			0%
Peak Hour Factor	0.90	0.90	0.90	0.90	0.90	0.90
Hourly flow rate (vph)	6	28	543	10	3	349
Pedestrians	19					2
Lane Width (ft)	12.0					12.0
Walking Speed (ft/s)	4.0					4.0
Percent Blockage	2					0
Right turn flare (veh)						
Median type			None			None
Median storage (veh)						
Upstream signal (ft)			227			556
pX, platoon unblocked	0.90	0.90			0.90	
vC, conflicting volume	748	569			572	
vC1, stage 1 conf vol						
vC2, stage 2 conf vol						
vCu, unblocked vol	660	460			464	
tC, single (s)	6.8	6.9			4.1	
tC, 2 stage (s)						
tF (s)	3.5	3.3			2.2	
p0 queue free %	98	94			100	
cM capacity (veh/h)	352	487			976	

Direction, Lane #	WB 1	NB 1	SB 1	SB 2
Volume Total	33	553	120	233
Volume Left	6	0	3	0
Volume Right	28	10	0	0
cSH	457	1700	976	1700
Volume to Capacity	0.07	0.33	0.00	0.14
Queue Length 95th (ft)	6	0	0	0
Control Delay (s)	13.5	0.0	0.3	0.0
Lane LOS	B		A	
Approach Delay (s)	13.5	0.0	0.1	
Approach LOS	B			

Intersection Summary			
Average Delay		0.5	
Intersection Capacity Utilization		37.0%	ICU Level of Service A
Analysis Period (min)		15	

HCM Unsignalized Intersection Capacity Analysis
7: RO Only & Martinazzi Ave

4/17/2013



Movement	WBL	WBR	NBT	NBR	SBL	SBT
Lane Configurations		↗	↑			↘
Volume (veh/h)	0	10	488	0	0	318
Sign Control	Stop		Free			Free
Grade	0%		0%			0%
Peak Hour Factor	0.89	0.89	0.89	0.89	0.89	0.89
Hourly flow rate (vph)	0	11	548	0	0	357
Pedestrians	13					
Lane Width (ft)	12.0					
Walking Speed (ft/s)	4.0					
Percent Blockage	1					
Right turn flare (veh)						
Median type			None			None
Median storage (veh)						
Upstream signal (ft)			125			658
pX, platoon unblocked	0.88	0.88			0.88	
vC, conflicting volume	740	561			561	
vC1, stage 1 conf vol						
vC2, stage 2 conf vol						
vCu, unblocked vol	640	438			438	
tC, single (s)	6.8	6.9			4.1	
tC, 2 stage (s)						
tF (s)	3.5	3.3			2.2	
p0 queue free %	100	98			100	
cM capacity (veh/h)	361	500			990	





















Direction, Lane #	WB 1	NB 1	SB 1	SB 2
Volume Total	11	548	179	179
Volume Left	0	0	0	0
Volume Right	11	0	0	0
cSH	500	1700	1700	1700
Volume to Capacity	0.02	0.32	0.11	0.11
Queue Length 95th (ft)	2	0	0	0
Control Delay (s)	12.4	0.0	0.0	0.0
Lane LOS	B			
Approach Delay (s)	12.4	0.0	0.0	
Approach LOS	B			

Intersection Summary			
Average Delay		0.2	
Intersection Capacity Utilization		35.7%	ICU Level of Service A
Analysis Period (min)		15	

HCM Signalized Intersection Capacity Analysis

8: Nyberg St & Martinazzi Ave

4/17/2013

													
Movement	EBL	EBT	EBR	WBL	WBT	WBR	NBL	NBT	NBR	SBL	SBT	SBR	
Lane Configurations													
Volume (vph)	16	1	63	227	37	237	23	235	31	0	310	8	
Ideal Flow (vphpl)	1900	1900	1900	1900	1900	1900	1900	1900	1900	1900	1900	1900	
Total Lost time (s)	5.5	5.5		5.5	5.5	5.5	5.5	5.5			5.5		
Lane Util. Factor	1.00	1.00		0.95	0.95	1.00	1.00	1.00			0.95		
Frpb, ped/bikes	1.00	1.00		1.00	1.00	0.97	1.00	1.00			1.00		
Flpb, ped/bikes	1.00	1.00		1.00	1.00	1.00	1.00	1.00			1.00		
Frt	1.00	0.85		1.00	1.00	0.85	1.00	0.98			1.00		
Flt Protected	0.95	1.00		0.95	0.97	1.00	0.95	1.00			1.00		
Satd. Flow (prot)	1805	1603		1698	1730	1542	1683	1842			3559		
Flt Permitted	0.95	1.00		0.95	0.97	1.00	0.54	1.00			1.00		
Satd. Flow (perm)	1805	1603		1698	1730	1542	960	1842			3559		
Peak-hour factor, PHF	0.91	0.91	0.91	0.91	0.91	0.91	0.91	0.91	0.91	0.91	0.91	0.91	
Adj. Flow (vph)	18	1	69	249	41	260	25	258	34	0	341	9	
RTOR Reduction (vph)	0	63	0	0	0	204	0	7	0	0	3	0	
Lane Group Flow (vph)	18	7	0	144	146	56	25	285	0	0	347	0	
Confl. Peds. (#/hr)	2					2	3		16	16		3	
Confl. Bikes (#/hr)						2						3	
Heavy Vehicles (%)	0%	0%	1%	1%	0%	2%	7%	1%	0%	0%	1%	0%	
Turn Type	Split			Split			Perm	Perm					
Protected Phases	8	8		4	4			6			2		
Permitted Phases						4	6						
Actuated Green, G (s)	3.1	3.1		8.9	8.9	8.9	13.8	13.8			13.8		
Effective Green, g (s)	3.6	3.6		9.4	9.4	9.4	14.3	14.3			14.3		
Actuated g/C Ratio	0.08	0.08		0.21	0.21	0.21	0.33	0.33			0.33		
Clearance Time (s)	6.0	6.0		6.0	6.0	6.0	6.0	6.0			6.0		
Vehicle Extension (s)	2.5	2.5		2.5	2.5	2.5	5.0	5.0			5.0		
Lane Grp Cap (vph)	148	132		364	371	331	313	601			1162		
v/s Ratio Prot	c0.01	0.00		c0.08	0.08			c0.15			0.10		
v/s Ratio Perm						0.04	0.03						
v/c Ratio	0.12	0.05		0.40	0.39	0.17	0.08	0.47			0.30		
Uniform Delay, d1	18.6	18.5		14.8	14.8	14.0	10.2	11.8			11.0		
Progression Factor	1.00	1.00		1.00	1.00	1.00	1.00	1.00			1.00		
Incremental Delay, d2	0.3	0.1		0.5	0.5	0.2	0.2	1.2			0.3		
Delay (s)	18.9	18.6		15.3	15.3	14.2	10.4	13.0			11.3		
Level of Service	B	B		B	B	B	B	B			B		
Approach Delay (s)		18.7			14.8			12.8			11.3		
Approach LOS		B			B			B			B		
Intersection Summary													
HCM Average Control Delay			13.6									HCM Level of Service	B
HCM Volume to Capacity ratio			0.40										
Actuated Cycle Length (s)			43.8									Sum of lost time (s)	16.5
Intersection Capacity Utilization			48.1%									ICU Level of Service	A
Analysis Period (min)			15										

c Critical Lane Group

HCM Unsignalized Intersection Capacity Analysis
 9: Nyberg St & Site Entrance 3

4/17/2013

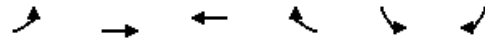





















Movement	EBL	EBT	WBT	WBR	SBL	SBR
Lane Configurations	↔		↕↔			↕↔
Volume (veh/h)	32	0	447	50	0	53
Sign Control		Free	Free		Stop	
Grade		0%	0%		0%	
Peak Hour Factor	0.88	0.88	0.88	0.88	0.88	0.88
Hourly flow rate (vph)	36	0	508	57	0	60
Pedestrians					4	
Lane Width (ft)					12.0	
Walking Speed (ft/s)					4.0	
Percent Blockage					0	
Right turn flare (veh)						
Median type		None	None			
Median storage (veh)						
Upstream signal (ft)		248				
pX, platoon unblocked						
vC, conflicting volume	569				613	286
vC1, stage 1 conf vol						
vC2, stage 2 conf vol						
vCu, unblocked vol	569				613	286
tC, single (s)	4.1				6.8	6.9
tC, 2 stage (s)						
tF (s)	2.2				3.5	3.3
p0 queue free %	96				100	92
cM capacity (veh/h)	1010				412	714
Direction, Lane #	EB 1	WB 1	WB 2	SB 1		
Volume Total	36	339	226	60		
Volume Left	36	0	0	0		
Volume Right	0	0	57	60		
cSH	1010	1700	1700	714		
Volume to Capacity	0.04	0.20	0.13	0.08		
Queue Length 95th (ft)	3	0	0	7		
Control Delay (s)	8.7	0.0	0.0	10.5		
Lane LOS	A			B		
Approach Delay (s)	8.7	0.0		10.5		
Approach LOS				B		
Intersection Summary						
Average Delay			1.4			
Intersection Capacity Utilization			24.0%		ICU Level of Service	A
Analysis Period (min)			15			

HCM Signalized Intersection Capacity Analysis

10: Tualatin Sherwood Rd & Site Entrance 4

4/17/2013

												
Movement	EBL	EBT	EBR	WBL	WBT	WBR	NBL	NBT	NBR	SBL	SBT	SBR
Lane Configurations												
Volume (vph)	50	1375	59	257	1498	101	57	25	248	154	40	62
Ideal Flow (vphpl)	1900	1900	1900	1900	1900	1900	1900	1900	1900	1900	1900	1900
Total Lost time (s)	4.5	6.0		4.5	6.0			5.0	4.5		5.0	5.0
Lane Util. Factor	1.00	*0.75		0.97	0.91			1.00	1.00		1.00	1.00
Frbp, ped/bikes	1.00	1.00		1.00	1.00			1.00	1.00		1.00	0.98
Flpb, ped/bikes	1.00	1.00		1.00	1.00			1.00	1.00		1.00	1.00
Frt	1.00	0.99		1.00	0.99			1.00	0.85		1.00	0.85
Flt Protected	0.95	1.00		0.95	1.00			0.97	1.00		0.96	1.00
Satd. Flow (prot)	1805	4092		3502	4943			1799	1599		1813	1579
Flt Permitted	0.95	1.00		0.95	1.00			0.50	1.00		0.71	1.00
Satd. Flow (perm)	1805	4092		3502	4943			925	1599		1347	1579
Peak-hour factor, PHF	0.98	0.98	0.98	0.98	0.98	0.98	0.98	0.98	0.98	0.98	0.98	0.98
Adj. Flow (vph)	51	1403	60	262	1529	103	58	26	253	157	41	63
RTOR Reduction (vph)	0	3	0	0	5	0	0	0	0	0	0	52
Lane Group Flow (vph)	51	1460	0	262	1627	0	0	84	253	0	198	11
Confl. Peds. (#/hr)							4					9
Confl. Bikes (#/hr)					1			1		1		
Heavy Vehicles (%)	0%	4%	0%	0%	4%	0%	3%	0%	1%	1%	0%	0%
Turn Type	Prot			Prot			Perm		pm+ov	Perm		Perm
Protected Phases	5	2		1	6			8	1		4	
Permitted Phases							8		8	4		4
Actuated Green, G (s)	8.0	65.9		11.7	69.6			20.4	32.1		20.4	20.4
Effective Green, g (s)	8.5	66.4		12.2	70.1			20.9	33.1		20.9	20.9
Actuated g/C Ratio	0.07	0.58		0.11	0.61			0.18	0.29		0.18	0.18
Clearance Time (s)	5.0	6.5		5.0	6.5			5.5	5.0		5.5	5.5
Vehicle Extension (s)	2.5	4.0		2.5	4.0			2.5	2.5		2.5	2.5
Lane Grp Cap (vph)	133	2363		372	3013			168	460		245	287
v/s Ratio Prot	0.03	c0.36		c0.07	0.33				0.06			
v/s Ratio Perm								0.09	0.10		c0.15	0.01
v/c Ratio	0.38	0.62		0.70	0.54			0.50	0.55		0.81	0.04
Uniform Delay, d1	50.8	16.0		49.7	13.1			42.3	34.6		45.1	38.8
Progression Factor	0.84	0.72		0.98	0.68			1.00	1.00		1.00	1.00
Incremental Delay, d2	1.1	1.0		4.4	0.6			1.7	1.1		17.1	0.0
Delay (s)	43.8	12.5		52.9	9.4			44.0	35.8		62.2	38.8
Level of Service	D	B		D	A			D	D		E	D
Approach Delay (s)		13.6			15.5			37.8			56.5	
Approach LOS		B			B			D			E	

Intersection Summary

HCM Average Control Delay	19.3	HCM Level of Service	B
HCM Volume to Capacity ratio	0.67		
Actuated Cycle Length (s)	115.0	Sum of lost time (s)	15.5
Intersection Capacity Utilization	70.3%	ICU Level of Service	C
Analysis Period (min)	15		

c Critical Lane Group

HCM Unsignalized Intersection Capacity Analysis
 11: Tualatin Sherwood Rd & 75th Ave

4/17/2013

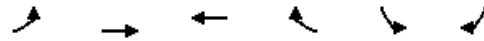













Movement	EBL	EBT	WBT	WBR	SBL	SBR	
Lane Configurations		↑↑↑	↑↑↑			↑	
Volume (veh/h)	0	1785	1847	48	0	15	
Sign Control		Free	Free		Stop		
Grade		0%	0%		0%		
Peak Hour Factor	0.97	0.97	0.97	0.97	0.97	0.97	
Hourly flow rate (vph)	0	1840	1904	49	0	15	
Pedestrians					6		
Lane Width (ft)					12.0		
Walking Speed (ft/s)					4.0		
Percent Blockage					1		
Right turn flare (veh)							
Median type		None	None				
Median storage (veh)							
Upstream signal (ft)		373	260				
pX, platoon unblocked	0.83				0.88	0.83	
vC, conflicting volume	1960				2548	665	
vC1, stage 1 conf vol							
vC2, stage 2 conf vol							
vCu, unblocked vol	1432				956	0	
tC, single (s)	4.1				6.8	7.4	
tC, 2 stage (s)							
tF (s)	2.2				3.5	3.5	
p0 queue free %	100				100	98	
cM capacity (veh/h)	396				227	835	
Direction, Lane #	EB 1	EB 2	EB 3	WB 1	WB 2	WB 3	SB 1
Volume Total	613	613	613	762	762	430	15
Volume Left	0	0	0	0	0	0	0
Volume Right	0	0	0	0	0	49	15
cSH	1700	1700	1700	1700	1700	1700	835
Volume to Capacity	0.36	0.36	0.36	0.45	0.45	0.25	0.02
Queue Length 95th (ft)	0	0	0	0	0	0	1
Control Delay (s)	0.0	0.0	0.0	0.0	0.0	0.0	9.4
Lane LOS							A
Approach Delay (s)	0.0			0.0			9.4
Approach LOS							A
Intersection Summary							
Average Delay			0.0				
Intersection Capacity Utilization			46.8%		ICU Level of Service		A
Analysis Period (min)			15				

HCM Signalized Intersection Capacity Analysis

12: Tualatin Sherwood Rd & I-5 SB Ramps













4/17/2013

													
Movement	EBL	EBT	EBR	WBL	WBT	WBR	NBL	NBT	NBR	SBL	SBT	SBR	
Lane Configurations		↑↑↑	↑	↑	↑↑					↑	↑	↑↑	
Volume (vph)	0	1370	415	193	1030	0	0	0	0	620	3	865	
Ideal Flow (vphpl)	1900	1900	1900	1900	1900	1900	1900	1900	1900	1900	1900	1900	
Total Lost time (s)		5.5	5.5	5.5	5.5					5.5	5.5	5.5	
Lane Util. Factor		*0.75	1.00	1.00	0.95					0.95	0.95	0.88	
Frbp, ped/bikes		1.00	1.00	1.00	1.00					1.00	1.00	1.00	
Flpb, ped/bikes		1.00	1.00	1.00	1.00					1.00	1.00	1.00	
Frt		1.00	0.85	1.00	1.00					1.00	1.00	0.85	
Flt Protected		1.00	1.00	0.95	1.00					0.95	0.95	1.00	
Satd. Flow (prot)		4150	1568	1787	3471					1681	1683	2760	
Flt Permitted		1.00	1.00	0.95	1.00					0.95	0.95	1.00	
Satd. Flow (perm)		4150	1568	1787	3471					1681	1683	2760	
Peak-hour factor, PHF	0.99	0.99	0.99	0.99	0.99	0.99	0.99	0.99	0.99	0.99	0.99	0.99	
Adj. Flow (vph)	0	1384	419	195	1040	0	0	0	0	626	3	874	
RTOR Reduction (vph)	0	0	208	0	0	0	0	0	0	0	0	61	
Lane Group Flow (vph)	0	1384	211	195	1040	0	0	0	0	313	316	813	
Confl. Bikes (#/hr)		1			2								
Heavy Vehicles (%)	0%	3%	3%	1%	4%	0%	0%	0%	0%	2%	20%	3%	
Turn Type			Perm	Prot						Split		custom	
Protected Phases		2		1	6					4	4	4.5	
Permitted Phases			2										
Actuated Green, G (s)		54.8	54.8	14.6	58.4					27.6	27.6	44.6	
Effective Green, g (s)		55.3	55.3	15.1	58.9					28.1	28.1	41.6	
Actuated g/C Ratio		0.48	0.48	0.13	0.51					0.24	0.24	0.36	
Clearance Time (s)		6.0	6.0	6.0	6.0					6.0	6.0		
Vehicle Extension (s)		6.1	6.1	2.3	6.1					2.3	2.3		
Lane Grp Cap (vph)		1996	754	235	1778					411	411	998	
v/s Ratio Prot		c0.33		c0.11	0.30					0.19	0.19	c0.29	
v/s Ratio Perm			0.13										
v/c Ratio		0.69	0.28	0.83	0.58					0.76	0.77	0.81	
Uniform Delay, d1		23.2	17.9	48.7	19.5					40.3	40.4	33.2	
Progression Factor		0.71	0.55	0.74	1.22					1.00	1.00	1.00	
Incremental Delay, d2		1.6	0.8	19.4	1.3					7.6	7.9	5.0	
Delay (s)		18.1	10.6	55.5	25.2					47.9	48.3	38.2	
Level of Service		B	B	E	C					D	D	D	
Approach Delay (s)		16.4			30.0			0.0			42.4		
Approach LOS		B			C			A			D		
Intersection Summary													
HCM Average Control Delay			28.7		HCM Level of Service					C			
HCM Volume to Capacity ratio			0.81										
Actuated Cycle Length (s)			115.0		Sum of lost time (s)			22.0					
Intersection Capacity Utilization			68.2%		ICU Level of Service			C					
Analysis Period (min)			15										
c Critical Lane Group													

HCM Signalized Intersection Capacity Analysis

13: Tualatin Sherwood Rd & I-5 NB Ramps





















4/17/2013

												
Movement	EBL	EBT	EBR	WBL	WBT	WBR	NBL	NBT	NBR	SBL	SBT	SBR
Lane Configurations		↑↑	↑↑		↑↑	↑	↑	↑	↑			
Volume (vph)	0	1077	917	0	628	666	592	0	219	0	0	0
Ideal Flow (vphpl)	1900	1900	1900	1900	1900	1900	1900	1900	1900	1900	1900	1900
Total Lost time (s)		5.5	5.5		6.0	6.0	5.5	5.5	5.5			
Lane Util. Factor		0.95	0.88		0.95	1.00	0.95	0.95	1.00			
Frbp, ped/bikes		1.00	0.98		1.00	1.00	1.00	1.00	0.98			
Flpb, ped/bikes		1.00	1.00		1.00	1.00	1.00	1.00	1.00			
Frt		1.00	0.85		1.00	0.85	1.00	1.00	0.85			
Flt Protected		1.00	1.00		1.00	1.00	0.95	0.95	1.00			
Satd. Flow (prot)		3574	2694		3574	1583	1618	1618	1559			
Flt Permitted		1.00	1.00		1.00	1.00	0.95	0.95	1.00			
Satd. Flow (perm)		3574	2694		3574	1583	1618	1618	1559			
Peak-hour factor, PHF	0.95	0.95	0.95	0.95	0.95	0.95	0.95	0.95	0.95	0.95	0.95	0.95
Adj. Flow (vph)	0	1134	965	0	661	701	623	0	231	0	0	0
RTOR Reduction (vph)	0	0	328	0	0	241	0	0	32	0	0	0
Lane Group Flow (vph)	0	1134	637	0	661	460	311	312	199	0	0	0
Confl. Peds. (#/hr)			1	1			1		2	2		1
Confl. Bikes (#/hr)		1			5					1		
Heavy Vehicles (%)	0%	1%	3%	0%	1%	2%	6%	20%	2%	0%	0%	0%
Turn Type			Perm			Perm	Split		Perm			
Protected Phases		2			6		8	8				
Permitted Phases			2			6			8			
Actuated Green, G (s)		75.4	75.4		74.9	74.9	27.6	27.6	27.6			
Effective Green, g (s)		75.9	75.9		75.4	75.4	28.1	28.1	28.1			
Actuated g/C Ratio		0.66	0.66		0.66	0.66	0.24	0.24	0.24			
Clearance Time (s)		6.0	6.0		6.5	6.5	6.0	6.0	6.0			
Vehicle Extension (s)		6.1	6.1		4.2	4.2	2.3	2.3	2.3			
Lane Grp Cap (vph)		2359	1778		2343	1038	395	395	381			
v/s Ratio Prot		c0.32			0.18		0.19	c0.19				
v/s Ratio Perm			0.24			0.29			0.13			
v/c Ratio		0.48	0.36		0.28	0.44	0.79	0.79	0.52			
Uniform Delay, d1		9.7	8.7		8.4	9.6	40.7	40.7	37.6			
Progression Factor		1.39	6.09		1.00	1.00	1.00	1.00	1.00			
Incremental Delay, d2		0.5	0.4		0.3	1.4	9.5	9.6	0.8			
Delay (s)		14.0	53.5		8.7	11.0	50.1	50.3	38.5			
Level of Service		B	D		A	B	D	D	D			
Approach Delay (s)		32.2			9.9			47.0			0.0	
Approach LOS		C			A			D			A	
Intersection Summary												
HCM Average Control Delay			28.1									C
HCM Volume to Capacity ratio			0.56									
Actuated Cycle Length (s)			115.0									11.0
Intersection Capacity Utilization			67.2%									C
Analysis Period (min)			15									

c Critical Lane Group

HCM Signalized Intersection Capacity Analysis
 14: Tualatin Sherwood Rd & Nyberg Woods

4/17/2013

												
Movement	EBL	EBT	EBR	WBL	WBT	WBR	NBL	NBT	NBR	SBL	SBT	SBR
Lane Configurations												
Volume (vph)	524	560	57	15	692	101	103	11	12	101	11	322
Ideal Flow (vphpl)	1900	1900	1900	1900	1900	1900	1900	1900	1900	1900	1900	1900
Total Lost time (s)	5.5	5.5		5.5	5.5			5.5	5.5		5.5	5.5
Lane Util. Factor	0.97	0.95		1.00	0.95			1.00	1.00		1.00	1.00
Frbp, ped/bikes	1.00	1.00		1.00	1.00			1.00	0.99		1.00	0.99
Flpb, ped/bikes	1.00	1.00		1.00	1.00			1.00	1.00		1.00	1.00
Frt	1.00	0.99		1.00	0.98			1.00	0.85		1.00	0.85
Flt Protected	0.95	1.00		0.95	1.00			0.96	1.00		0.96	1.00
Satd. Flow (prot)	3502	3483		1805	3502			1768	1593		1799	1594
Flt Permitted	0.95	1.00		0.95	1.00			0.66	1.00		0.66	1.00
Satd. Flow (perm)	3502	3483		1805	3502			1229	1593		1249	1594
Peak-hour factor, PHF	0.96	0.96	0.96	0.96	0.96	0.96	0.96	0.96	0.96	0.96	0.96	0.96
Adj. Flow (vph)	546	583	59	16	721	105	107	11	12	105	11	335
RTOR Reduction (vph)	0	5	0	0	10	0	0	0	10	0	0	282
Lane Group Flow (vph)	546	637	0	16	816	0	0	118	2	0	116	53
Confl. Peds. (#/hr)	8		2	2		8	1		2	2		1
Confl. Bikes (#/hr)		1			3							
Heavy Vehicles (%)	0%	2%	2%	0%	1%	0%	3%	0%	0%	1%	0%	0%
Turn Type	Prot			Prot			Perm		Perm	Perm		Perm
Protected Phases	5	2		1	6			8				4
Permitted Phases							8		8	4		4
Actuated Green, G (s)	13.9	36.2		0.8	23.1			9.8	9.8			9.8
Effective Green, g (s)	14.4	36.7		1.3	23.6			10.3	10.3			10.3
Actuated g/C Ratio	0.22	0.57		0.02	0.36			0.16	0.16			0.16
Clearance Time (s)	6.0	6.0		6.0	6.0			6.0	6.0			6.0
Vehicle Extension (s)	2.3	2.5		2.4	2.5			2.4	2.4			2.3
Lane Grp Cap (vph)	778	1973		36	1275			195	253			199
v/s Ratio Prot	c0.16	0.18		0.01	c0.23							
v/s Ratio Perm								c0.10	0.00			0.09
v/c Ratio	0.70	0.32		0.44	0.64			0.61	0.01			0.58
Uniform Delay, d1	23.2	7.5		31.4	17.1			25.4	22.9			25.3
Progression Factor	1.00	1.00		1.00	1.00			1.00	1.00			1.00
Incremental Delay, d2	2.5	0.1		5.6	0.9			4.3	0.0			3.3
Delay (s)	25.8	7.5		37.0	18.0			29.6	23.0			28.5
Level of Service	C	A		D	B			C	C			C
Approach Delay (s)		15.9			18.4			29.0				25.1
Approach LOS		B			B			C				C

























Intersection Summary		
HCM Average Control Delay	18.9	HCM Level of Service B
HCM Volume to Capacity ratio	0.65	
Actuated Cycle Length (s)	64.8	Sum of lost time (s) 16.5
Intersection Capacity Utilization	64.5%	ICU Level of Service C
Analysis Period (min)	15	

c Critical Lane Group

HCM Signalized Intersection Capacity Analysis

17: Tualatin Sherwood Rd & Martinazzi Ave

4/17/2013

												
Movement	EBL	EBT	EBR	WBL	WBT	WBR	NBL	NBT	NBR	SBL	SBT	SBR
Lane Configurations		 			 						 	
Volume (vph)	69	1140	141	0	1119	0	100	221	216	129	382	88
Ideal Flow (vphpl)	1900	1900	1900	1900	1900	1900	1900	1900	1900	1900	1900	1900
Total Lost time (s)	4.5	5.5			5.5		4.5	5.5	5.5	4.5	5.5	
Lane Util. Factor	1.00	0.95			0.95		1.00	1.00	1.00	1.00	0.95	
Frbp, ped/bikes	1.00	1.00			1.00		1.00	1.00	0.96	1.00	1.00	
Flpb, ped/bikes	1.00	1.00			1.00		1.00	1.00	1.00	1.00	1.00	
Frt	1.00	0.98			1.00		1.00	1.00	0.85	1.00	0.97	
Flt Protected	0.95	1.00			1.00		0.95	1.00	1.00	0.95	1.00	
Satd. Flow (prot)	1719	3428			3438		1770	1863	1537	1787	3463	
Flt Permitted	0.95	1.00			1.00		0.95	1.00	1.00	0.95	1.00	
Satd. Flow (perm)	1719	3428			3438		1770	1863	1537	1787	3463	
Peak-hour factor, PHF	0.94	0.94	0.94	0.94	0.94	0.94	0.94	0.94	0.94	0.94	0.94	0.94
Adj. Flow (vph)	73	1213	150	0	1190	0	106	235	230	137	406	94
RTOR Reduction (vph)	0	6	0	0	0	0	0	0	108	0	20	0
Lane Group Flow (vph)	73	1357	0	0	1190	0	106	235	122	137	480	0
Confl. Peds. (#/hr)							6		23			3
Heavy Vehicles (%)	5%	4%	0%	0%	5%	0%	2%	2%	1%	1%	1%	1%
Turn Type	Prot						Prot		Perm	Prot		
Protected Phases	5	2			6		3	8		7	4	
Permitted Phases									8			
Actuated Green, G (s)	7.4	67.3			54.9		10.6	17.7	17.7	13.0	20.1	
Effective Green, g (s)	7.9	67.8			55.4		11.1	18.2	18.2	13.5	20.6	
Actuated g/C Ratio	0.07	0.59			0.48		0.10	0.16	0.16	0.12	0.18	
Clearance Time (s)	5.0	6.0			6.0		5.0	6.0	6.0	5.0	6.0	
Vehicle Extension (s)	2.0	3.5			3.5		3.0	2.0	2.0	3.0	2.0	
Lane Grp Cap (vph)	118	2021			1656		171	295	243	210	620	
v/s Ratio Prot	0.04	c0.40			c0.35		0.06	c0.13		0.08	c0.14	
v/s Ratio Perm									0.08			
v/c Ratio	0.62	0.67			0.72		0.62	0.80	0.50	0.65	0.77	
Uniform Delay, d1	52.1	16.0			23.6		49.9	46.6	44.3	48.5	45.0	
Progression Factor	1.00	1.00			0.46		1.00	1.00	1.00	1.00	1.00	
Incremental Delay, d2	6.6	1.8			2.4		6.5	13.0	0.6	7.1	5.5	
Delay (s)	58.7	17.8			13.3		56.5	59.6	44.9	55.6	50.5	
Level of Service	E	B			B		E	E	D	E	D	
Approach Delay (s)		19.9			13.3			53.1			51.6	
Approach LOS		B			B			D			D	
Intersection Summary												
HCM Average Control Delay			28.1				HCM Level of Service			C		
HCM Volume to Capacity ratio			0.78									
Actuated Cycle Length (s)			115.0				Sum of lost time (s)		22.0			
Intersection Capacity Utilization			79.8%				ICU Level of Service		D			
Analysis Period (min)			15									
c Critical Lane Group												

Intersection: 12: Tualatin Sherwood Rd & I-5 SB Ramps

Movement	EB	EB	EB	EB	WB	WB	WB	SB	SB	SB	SB
Directions Served	T	T	T	R	L	T	T	L	LT	R	R
Maximum Queue (ft)	187	219	211	107	391	526	506	275	592	473	336
Average Queue (ft)	137	147	148	8	191	283	312	185	295	210	120
95th Queue (ft)	209	216	215	47	324	418	437	285	540	396	270
Link Distance (ft)	169	169	169	169	625	625	625		1146	1146	
Upstream Blk Time (%)	5	6	6	0							
Queuing Penalty (veh)	22	25	26	0							
Storage Bay Dist (ft)								200			700
Storage Blk Time (%)								4	19	0	0
Queuing Penalty (veh)								12	60	1	0

Intersection: 13: Tualatin Sherwood Rd & I-5 NB Ramps

Movement	EB	EB	EB	EB	WB	WB	WB	NB	NB	NB	B33
Directions Served	T	T	R	R	T	T	R	L	LT	R	T
Maximum Queue (ft)	474	446	57	55	269	381	223	323	444	296	61
Average Queue (ft)	289	252	2	2	104	138	19	174	232	101	4
95th Queue (ft)	442	397	44	43	209	265	120	275	372	229	51
Link Distance (ft)	625	625	625	625	459	459			467		253
Upstream Blk Time (%)						0			0		0
Queuing Penalty (veh)						1			0		0
Storage Bay Dist (ft)							150	300		225	
Storage Blk Time (%)						5		0	8	0	
Queuing Penalty (veh)						33		1	41	1	

Appendix F
Year 2014 Total Traffic
Operations Worksheets

2010 Network: Select Zone Vehicles (Total PM Peak 1-Hour Vehicles)

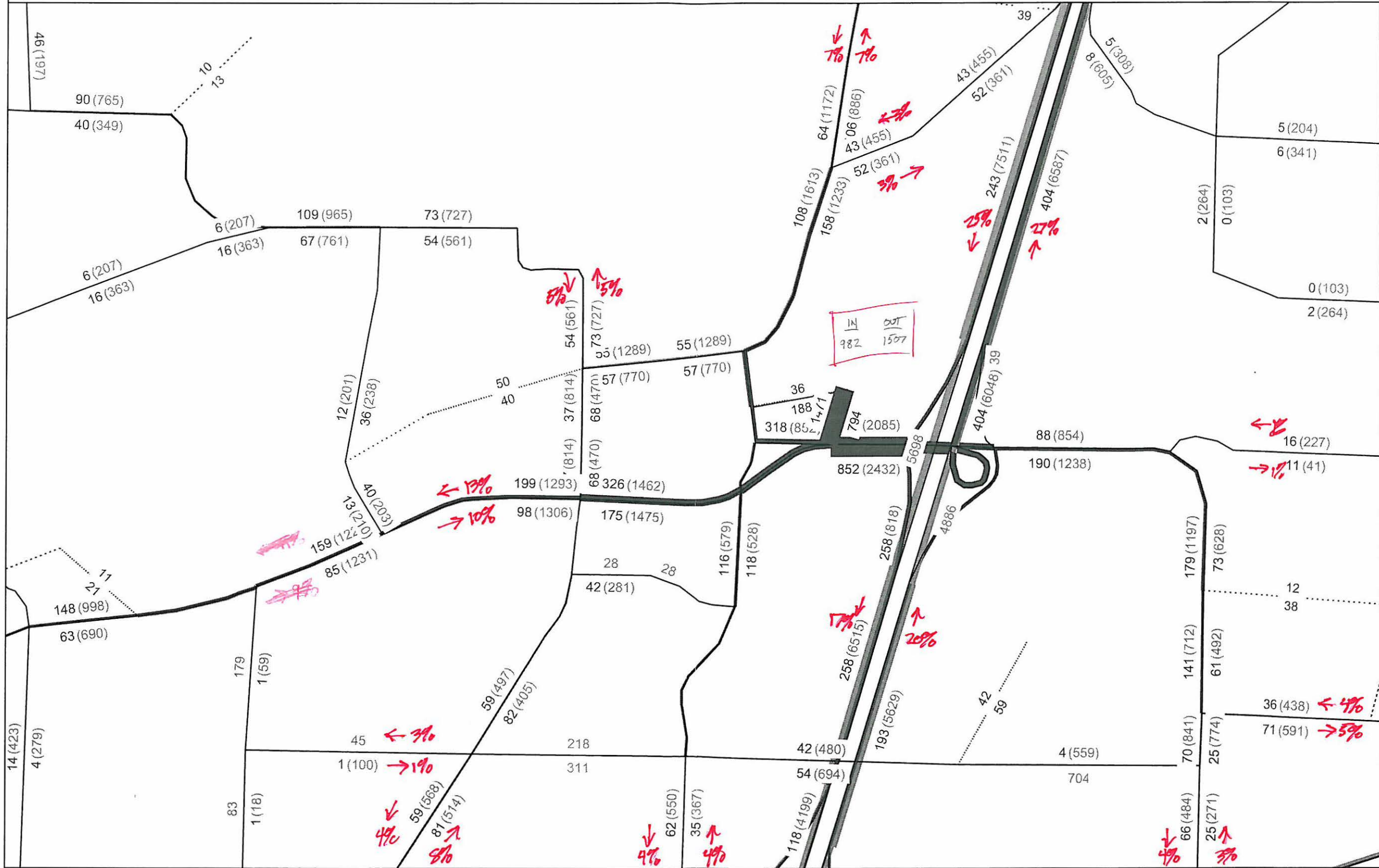





















Washington County	Westside Focus Model	2010 Existing Network
Steve L Kelley	2010_PM2veh_SZ_Tualatin.ver	15.06.2012

HCM Signalized Intersection Capacity Analysis

1: Lower Boones Ferry Road & SW Upper Boones Ferry Road















4/15/2013

												
Movement	EBL	EBT	EBR	WBL	WBT	WBR	NBL	NBT	NBR	SBL	SBT	SBR
Lane Configurations												
Volume (vph)	1	7	9	479	7	40	0	504	567	59	697	1
Ideal Flow (vphpl)	1900	1900	1900	1900	1900	1900	1900	1900	1900	1900	1900	1900
Total Lost time (s)		3.5		3.5	3.5			4.0	3.5	3.5	4.0	
Lane Util. Factor		1.00		1.00	1.00			1.00	1.00	1.00	1.00	
Frbp, ped/bikes		0.92		1.00	0.95			1.00	0.98	1.00	1.00	
Flpb, ped/bikes		1.00		1.00	1.00			1.00	1.00	1.00	1.00	
Frt		0.93		1.00	0.87			1.00	0.85	1.00	1.00	
Flt Protected		1.00		0.95	1.00			1.00	1.00	0.95	1.00	
Satd. Flow (prot)		1596		1787	1574			1900	1570	1805	1900	
Flt Permitted		1.00		0.95	1.00			1.00	1.00	0.95	1.00	
Satd. Flow (perm)		1596		1787	1574			1900	1570	1805	1900	
Peak-hour factor, PHF	0.95	0.95	0.95	0.95	0.95	0.95	0.95	0.95	0.95	0.95	0.95	0.95
Adj. Flow (vph)	1	7	9	504	7	42	0	531	597	62	734	1
RTOR Reduction (vph)	0	9	0	0	26	0	0	0	158	0	0	0
Lane Group Flow (vph)	0	8	0	504	23	0	0	531	439	62	735	0
Confl. Peds. (#/hr)	15		7	7		15	7		8	8		7
Heavy Vehicles (%)	0%	2%	1%	1%	3%	0%	2%	0%	1%	0%	0%	0%
Turn Type	Split			Split			Prot		pm+ov		Prot	
Protected Phases	8	8		4	4		1	6	4	5	2	
Permitted Phases									6			
Actuated Green, G (s)		1.7		31.9	31.9			29.5	61.4	5.3	38.8	
Effective Green, g (s)		2.2		32.4	32.4			30.0	62.4	5.8	39.3	
Actuated g/C Ratio		0.03		0.38	0.38			0.35	0.73	0.07	0.46	
Clearance Time (s)		4.0		4.0	4.0			4.5	4.0	4.0	4.5	
Vehicle Extension (s)		2.5		2.2	2.2			3.5	2.2	2.2	3.5	
Lane Grp Cap (vph)		41		682	601			671	1154	123	880	
v/s Ratio Prot		c0.01		c0.28	0.01			0.28	0.15	0.03	c0.39	
v/s Ratio Perm									0.13			
v/c Ratio		0.20		0.74	0.04			0.79	0.38	0.50	0.84	
Uniform Delay, d1		40.5		22.6	16.5			24.6	4.1	38.2	20.0	
Progression Factor		1.00		1.00	1.00			1.00	1.00	1.00	1.00	
Incremental Delay, d2		1.8		3.8	0.0			6.5	0.1	1.7	7.1	
Delay (s)		42.2		26.4	16.5			31.2	4.2	39.8	27.0	
Level of Service		D		C	B			C	A	D	C	
Approach Delay (s)		42.2			25.5			16.9			28.0	
Approach LOS		D			C			B			C	
Intersection Summary												
HCM Average Control Delay			22.5			HCM Level of Service				C		
HCM Volume to Capacity ratio			0.77									
Actuated Cycle Length (s)			84.9			Sum of lost time (s)			11.0			
Intersection Capacity Utilization			83.3%			ICU Level of Service				E		
Analysis Period (min)			15									
c Critical Lane Group												

HCM Signalized Intersection Capacity Analysis

2: SW Boones Ferry Rd & SW Tualatin Rd

4/15/2013

						
Movement	WBL	WBR	NBT	NBR	SBL	SBT
Lane Configurations	 			 	 	
Volume (vph)	410	844	200	298	453	365
Ideal Flow (vphpl)	1900	1900	1900	1900	1900	1900
Total Lost time (s)	3.5	3.5	3.0	3.5	3.5	3.5
Lane Util. Factor	0.97	1.00	1.00	1.00	1.00	1.00
Frpb, ped/bikes	1.00	0.98	1.00	0.98	1.00	1.00
Flpb, ped/bikes	1.00	1.00	1.00	1.00	1.00	1.00
Fr t	1.00	0.85	1.00	0.85	1.00	1.00
Fl t Protected	0.95	1.00	1.00	1.00	0.95	1.00
Satd. Flow (prot)	3467	1590	1900	1574	1805	1900
Fl t Permitted	0.95	1.00	1.00	1.00	0.95	1.00
Satd. Flow (perm)	3467	1590	1900	1574	1805	1900
Peak-hour factor, PHF	0.95	0.95	0.95	0.95	0.95	0.95
Adj. Flow (vph)	432	888	211	314	477	384
RTOR Reduction (vph)	0	182	0	75	0	0
Lane Group Flow (vph)	432	706	211	239	477	384
Confl. Peds. (#/hr)	7	15		8	8	
Heavy Vehicles (%)	1%	0%	0%	1%	0%	0%
Turn Type		pm+ov		pm+ov	Prot	
Protected Phases	8	1	2	8	1	6
Permitted Phases		8		2		
Actuated Green, G (s)	11.4	32.2	10.7	22.1	20.8	35.0
Effective Green, g (s)	11.9	33.2	11.2	23.1	21.3	35.5
Actuated g/C Ratio	0.22	0.61	0.21	0.42	0.39	0.65
Clearance Time (s)	4.0	4.0	3.5	4.0	4.0	4.0
Vehicle Extension (s)	3.0	2.0	5.0	3.0	2.0	2.0
Lane Grp Cap (vph)	758	1073	391	668	707	1240
v/s Ratio Prot	0.12	c0.26	c0.11	0.08	0.26	0.20
v/s Ratio Perm		0.19		0.07		
v/c Ratio	0.57	0.66	0.54	0.36	0.67	0.31
Uniform Delay, d1	19.0	6.9	19.3	10.6	13.7	4.1
Progression Factor	1.00	1.00	1.00	1.00	1.00	1.00
Incremental Delay, d2	1.0	1.1	2.6	0.3	2.0	0.1
Delay (s)	20.0	8.0	21.9	10.9	15.7	4.2
Level of Service	B	A	C	B	B	A
Approach Delay (s)	11.9		15.4			10.6
Approach LOS	B		B			B
Intersection Summary						
HCM Average Control Delay			12.2		HCM Level of Service	B
HCM Volume to Capacity ratio			0.63			
Actuated Cycle Length (s)			54.4		Sum of lost time (s)	6.5
Intersection Capacity Utilization			72.2%		ICU Level of Service	C
Analysis Period (min)			15			
c Critical Lane Group						

HCM Signalized Intersection Capacity Analysis

3: SW Boones Fe & SW Martinazzi Ave

28/03/2013



Movement	EBT	EBR	WBL	WBT	NBL	NBR
Lane Configurations	↑	↑	↑	↑	↑	↑
Volume (vph)	664	185	453	930	335	415
Ideal Flow (vphpl)	1900	1900	1900	1900	1900	1900
Total Lost time (s)	4.5	4.5	4.5	4.5	4.5	4.5
Lane Util. Factor	1.00	1.00	1.00	1.00	1.00	1.00
Frbp, ped/bikes	1.00	1.00	1.00	1.00	1.00	0.98
Flpb, ped/bikes	1.00	1.00	1.00	1.00	1.00	1.00
Frt	1.00	0.85	1.00	1.00	1.00	0.85
Flt Protected	1.00	1.00	0.95	1.00	0.95	1.00
Satd. Flow (prot)	1863	1599	1787	1845	1770	1571
Flt Permitted	1.00	1.00	0.95	1.00	0.95	1.00
Satd. Flow (perm)	1863	1599	1787	1845	1770	1571
Peak-hour factor, PHF	0.95	0.95	0.95	0.95	0.95	0.95
Adj. Flow (vph)	699	195	477	979	353	437
RTOR Reduction (vph)	0	65	0	0	0	33
Lane Group Flow (vph)	699	130	477	979	353	404
Confl. Peds. (#/hr)		7	7		7	8
Heavy Vehicles (%)	2%	1%	1%	3%	2%	1%
Turn Type		Prot	Prot		pm+ov	
Protected Phases	2	2	1	6	8	1
Permitted Phases					8	8
Actuated Green, G (s)	41.2	41.2	31.8	78.0	24.1	55.9
Effective Green, g (s)	41.7	41.7	32.3	78.5	24.6	56.9
Actuated g/C Ratio	0.37	0.37	0.29	0.70	0.22	0.51
Clearance Time (s)	5.0	5.0	5.0	5.0	5.0	5.0
Vehicle Extension (s)	3.0	3.0	3.0	3.0	3.0	3.0
Lane Grp Cap (vph)	693	595	515	1292	388	860
v/s Ratio Prot	c0.38	0.08	c0.27	0.53	c0.20	0.14
v/s Ratio Perm						0.12
v/c Ratio	1.01	0.22	0.93	0.76	0.91	0.47
Uniform Delay, d1	35.2	24.1	38.7	10.7	42.7	17.8
Progression Factor	1.00	1.00	1.00	1.00	1.00	1.00
Incremental Delay, d2	36.3	0.2	22.7	2.6	24.5	0.4
Delay (s)	71.5	24.2	61.5	13.3	67.2	18.2
Level of Service	E	C	E	B	E	B
Approach Delay (s)	61.2			29.1	40.1	
Approach LOS	E			C	D	

Intersection Summary			
HCM Average Control Delay	41.0	HCM Level of Service	D
HCM Volume to Capacity ratio	0.96		
Actuated Cycle Length (s)	112.1	Sum of lost time (s)	13.5
Intersection Capacity Utilization	89.9%	ICU Level of Service	E
Analysis Period (min)	15		
c Critical Lane Group			

HCM Unsignalized Intersection Capacity Analysis

4: SW Martinazzi Ave &

28/03/2013



Movement	WBL	WBR	NBT	NBR	SBL	SBT
Lane Configurations						
Volume (veh/h)	53	166	582	93	202	434
Sign Control	Stop		Free			Free
Grade	0%		0%			0%
Peak Hour Factor	0.92	0.92	0.92	0.92	0.92	0.92
Hourly flow rate (vph)	58	180	633	101	220	472
Pedestrians						
Lane Width (ft)						
Walking Speed (ft/s)						
Percent Blockage						
Right turn flare (veh)						
Median type			None		TWLTL	
Median storage veh					2	
Upstream signal (ft)			477		306	
pX, platoon unblocked	0.91	0.91			0.91	
vC, conflicting volume	1594	683			734	
vC1, stage 1 conf vol	683					
vC2, stage 2 conf vol	911					
vCu, unblocked vol	1603	604			660	
tC, single (s)	6.4	6.2			4.1	
tC, 2 stage (s)	5.4					
tF (s)	3.5	3.3			2.2	
p0 queue free %	77	60			74	
cM capacity (veh/h)	253	454			847	

Direction, Lane #	WB 1	WB 2	NB 1	SB 1	SB 2
Volume Total	58	180	734	220	472
Volume Left	58	0	0	220	0
Volume Right	0	180	101	0	0
cSH	253	454	1700	847	1700
Volume to Capacity	0.23	0.40	0.43	0.26	0.28
Queue Length 95th (ft)	21	47	0	26	0
Control Delay (s)	23.3	18.0	0.0	10.7	0.0
Lane LOS	C	C		B	
Approach Delay (s)	19.3		0.0	3.4	
Approach LOS	C				

Intersection Summary					
Average Delay			4.2		
Intersection Capacity Utilization			60.8%	ICU Level of Service	B
Analysis Period (min)			15		

HCM Unsignalized Intersection Capacity Analysis

5: Seneca St & Martinazzi Ave

28/03/2013



Movement	EBL	EBR	NBL	NBT	SBT	SBR
Lane Configurations						
Volume (veh/h)	40	80	85	642	446	50
Sign Control	Stop			Free	Free	
Grade	0%			0%	0%	
Peak Hour Factor	0.91	0.91	0.91	0.91	0.91	0.91
Hourly flow rate (vph)	44	88	93	705	490	55
Pedestrians	5			16	26	
Lane Width (ft)	12.0			12.0	12.0	
Walking Speed (ft/s)	4.0			4.0	4.0	
Percent Blockage	0			1	2	
Right turn flare (veh)						
Median type				None	None	
Median storage (veh)						
Upstream signal (ft)				316	467	
pX, platoon unblocked	0.89					
vC, conflicting volume	1441	539	550			
vC1, stage 1 conf vol						
vC2, stage 2 conf vol						
vCu, unblocked vol	1434	539	550			
tC, single (s)	6.4	6.2	4.1			
tC, 2 stage (s)						
tF (s)	3.5	3.3	2.2			
p0 queue free %	63	84	91			
cM capacity (veh/h)	118	537	1026			

Direction, Lane #	EB 1	NB 1	NB 2	SB 1
Volume Total	132	93	705	545
Volume Left	44	93	0	0
Volume Right	88	0	0	55
cSH	245	1026	1700	1700
Volume to Capacity	0.54	0.09	0.41	0.32
Queue Length 95th (ft)	72	7	0	0
Control Delay (s)	35.5	8.9	0.0	0.0
Lane LOS	E	A		
Approach Delay (s)	35.5	1.0		0.0
Approach LOS	E			

Intersection Summary			
Average Delay		3.7	
Intersection Capacity Utilization		51.6%	ICU Level of Service A
Analysis Period (min)		15	

HCM Unsignalized Intersection Capacity Analysis

6: Martinazzi Ave &

28/03/2013



Movement	WBL	WBR	NBT	NBR	SBL	SBT
Lane Configurations						
Volume (veh/h)	0	32	695	6	10	517
Sign Control	Stop		Free			Free
Grade	0%		0%			0%
Peak Hour Factor	0.91	0.91	0.91	0.91	0.91	0.91
Hourly flow rate (vph)	0	35	764	7	11	568
Pedestrians	26					25
Lane Width (ft)	12.0					12.0
Walking Speed (ft/s)	4.0					4.0
Percent Blockage	2					2
Right turn flare (veh)						
Median type			None			None
Median storage (veh)						
Upstream signal (ft)			223			560
pX, platoon unblocked	0.85	0.85			0.85	
vC, conflicting volume	1099	818			796	
vC1, stage 1 conf vol						
vC2, stage 2 conf vol						
vCu, unblocked vol	1029	699			674	
tC, single (s)	6.8	6.9			4.1	
tC, 2 stage (s)						
tF (s)	3.5	3.3			2.2	
p0 queue free %	100	89			99	
cM capacity (veh/h)	188	312			761	

Direction, Lane #	WB 1	NB 1	SB 1	SB 2
Volume Total	35	770	200	379
Volume Left	0	0	11	0
Volume Right	35	7	0	0
cSH	312	1700	761	1700
Volume to Capacity	0.11	0.45	0.01	0.22
Queue Length 95th (ft)	9	0	1	0
Control Delay (s)	18.0	0.0	0.7	0.0
Lane LOS	C		A	
Approach Delay (s)	18.0	0.0	0.2	
Approach LOS	C			

Intersection Summary			
Average Delay		0.6	
Intersection Capacity Utilization		53.0%	ICU Level of Service A
Analysis Period (min)		15	

HCM Unsignalized Intersection Capacity Analysis

7: Martinazzi Ave &

28/03/2013























Movement	WBL	WBR	NBT	NBR	SBL	SBT
Lane Configurations		↖	↑			↗↗
Volume (veh/h)	0	12	682	0	0	509
Sign Control	Stop		Free			Free
Grade	0%		0%			0%
Peak Hour Factor	0.89	0.89	0.89	0.89	0.89	0.89
Hourly flow rate (vph)	0	13	766	0	0	572
Pedestrians						
Lane Width (ft)						
Walking Speed (ft/s)						
Percent Blockage						
Right turn flare (veh)						
Median type			None			None
Median storage (veh)						
Upstream signal (ft)			101			682
pX, platoon unblocked	0.84	0.84			0.84	
vC, conflicting volume	1052	766			766	
vC1, stage 1 conf vol						
vC2, stage 2 conf vol						
vCu, unblocked vol	970	632			632	
tC, single (s)	6.8	6.9			4.1	
tC, 2 stage (s)						
tF (s)	3.5	3.3			2.2	
p0 queue free %	100	96			100	
cM capacity (veh/h)	212	358			800	

Direction, Lane #	WB 1	NB 1	SB 1	SB 2
Volume Total	13	766	286	286
Volume Left	0	0	0	0
Volume Right	13	0	0	0
cSH	358	1700	1700	1700
Volume to Capacity	0.04	0.45	0.17	0.17
Queue Length 95th (ft)	3	0	0	0
Control Delay (s)	15.5	0.0	0.0	0.0
Lane LOS	C			
Approach Delay (s)	15.5	0.0	0.0	
Approach LOS	C			

Intersection Summary			
Average Delay		0.2	
Intersection Capacity Utilization		45.9%	ICU Level of Service A
Analysis Period (min)		15	

HCM Signalized Intersection Capacity Analysis
 8: Nyberg St & Martinazzi Ave

4/15/2013

													
Movement	EBL	EBT	EBR	WBL	WBT	WBR	NBL	NBT	NBR	SBL	SBT	SBR	
Lane Configurations													
Volume (vph)	29	10	100	357	55	337	27	315	26	0	499	10	
Ideal Flow (vphpl)	1900	1900	1900	1900	1900	1900	1900	1900	1900	1900	1900	1900	
Total Lost time (s)	4.0	4.0		4.0	4.0	4.0	4.0	4.0			4.0		
Lane Util. Factor	1.00	1.00		0.95	0.95	1.00	1.00	1.00			0.95		
Frpb, ped/bikes	1.00	1.00		1.00	1.00	0.97	1.00	1.00			1.00		
Flpb, ped/bikes	1.00	1.00		1.00	1.00	1.00	1.00	1.00			1.00		
Frt	1.00	0.86		1.00	1.00	0.85	1.00	0.99			1.00		
Flt Protected	0.95	1.00		0.95	0.96	1.00	0.95	1.00			1.00		
Satd. Flow (prot)	1805	1626		1698	1728	1533	1682	1855			3563		
Flt Permitted	0.95	1.00		0.95	0.96	1.00	0.40	1.00			1.00		
Satd. Flow (perm)	1805	1626		1698	1728	1533	701	1855			3563		
Peak-hour factor, PHF	0.91	0.91	0.91	0.91	0.91	0.91	0.91	0.91	0.91	0.91	0.91	0.91	
Adj. Flow (vph)	32	11	110	392	60	370	30	346	29	0	548	11	
RTOR Reduction (vph)	0	96	0	0	0	276	0	4	0	0	2	0	
Lane Group Flow (vph)	32	25	0	223	229	94	30	371	0	0	557	0	
Confl. Peds. (#/hr)	10					10	6		19	19		6	
Heavy Vehicles (%)	0%	0%	1%	1%	0%	2%	7%	1%	0%	0%	1%	0%	
Turn Type	Split			Split		Perm	Perm						
Protected Phases	8	8		4	4			6				2	
Permitted Phases						4	6						
Actuated Green, G (s)	4.8	4.8		10.3	10.3	10.3	13.7	13.7				13.7	
Effective Green, g (s)	5.3	5.3		10.8	10.8	10.8	14.2	14.2				14.2	
Actuated g/C Ratio	0.13	0.13		0.26	0.26	0.26	0.34	0.34				0.34	
Clearance Time (s)	4.5	4.5		4.5	4.5	4.5	4.5	4.5				4.5	
Vehicle Extension (s)	2.5	2.5		2.5	2.5	2.5	5.0	5.0				5.0	
Lane Grp Cap (vph)	226	204		434	441	391	235	623				1196	
v/s Ratio Prot	c0.02	0.02		0.13	c0.13			c0.20				0.16	
v/s Ratio Perm						0.06	0.04						
v/c Ratio	0.14	0.12		0.51	0.52	0.24	0.13	0.60				0.47	
Uniform Delay, d1	16.5	16.4		13.5	13.5	12.5	9.8	11.7				11.1	
Progression Factor	1.00	1.00		1.00	1.00	1.00	1.00	1.00				1.00	
Incremental Delay, d2	0.2	0.2		0.8	0.8	0.2	0.5	2.3				0.6	
Delay (s)	16.7	16.6		14.3	14.3	12.7	10.3	14.0				11.7	
Level of Service	B	B		B	B	B	B	B				B	
Approach Delay (s)		16.6			13.6			13.7				11.7	
Approach LOS		B			B			B				B	
Intersection Summary													
HCM Average Control Delay			13.3									HCM Level of Service	B
HCM Volume to Capacity ratio			0.49										
Actuated Cycle Length (s)			42.3									Sum of lost time (s)	12.0
Intersection Capacity Utilization			56.9%									ICU Level of Service	B
Analysis Period (min)			15										
c Critical Lane Group													

HCM Unsignalized Intersection Capacity Analysis

9: Nyberg St & Site Entrance 3

























4/15/2013



Movement	EBL	EBT	WBT	WBR	SBL	SBR
Lane Configurations	↖		↕↗			↗
Volume (veh/h)	35	0	648	51	0	100
Sign Control		Free	Free		Stop	
Grade		0%	0%		0%	
Peak Hour Factor	0.88	0.88	0.88	0.88	0.88	0.88
Hourly flow rate (vph)	40	0	736	58	0	114
Pedestrians					5	
Lane Width (ft)					12.0	
Walking Speed (ft/s)					4.0	
Percent Blockage					0	
Right turn flare (veh)						
Median type		None	None			
Median storage (veh)						
Upstream signal (ft)		278				
pX, platoon unblocked						
vC, conflicting volume	799				850	402
vC1, stage 1 conf vol						
vC2, stage 2 conf vol						
vCu, unblocked vol	799				850	402
tC, single (s)	4.1				6.8	6.9
tC, 2 stage (s)						
tF (s)	2.2				3.5	3.3
p0 queue free %	95				100	81
cM capacity (veh/h)	829				288	601
Direction, Lane #	EB 1	WB 1	WB 2	SB 1		
Volume Total	40	491	303	114		
Volume Left	40	0	0	0		
Volume Right	0	0	58	114		
cSH	829	1700	1700	601		
Volume to Capacity	0.05	0.29	0.18	0.19		
Queue Length 95th (ft)	4	0	0	17		
Control Delay (s)	9.6	0.0	0.0	12.4		
Lane LOS	A			B		
Approach Delay (s)	9.6	0.0		12.4		
Approach LOS				B		
Intersection Summary						
Average Delay			1.9			
Intersection Capacity Utilization			32.4%		ICU Level of Service	A
Analysis Period (min)			15			

HCM Signalized Intersection Capacity Analysis
 10: Tualatin Sherwood Rd & Site Entrance 4













4/15/2013

												
Movement	EBL	EBT	EBR	WBL	WBT	WBR	NBL	NBT	NBR	SBL	SBT	SBR
Lane Configurations		 		 	 					 		
Volume (vph)	99	1899	40	232	1694	251	36	10	236	323	24	113
Ideal Flow (vphpl)	1900	1900	1900	1900	1900	1900	1900	1900	1900	1900	1900	1900
Total Lost time (s)	4.5	6.0		4.5	6.0	6.0		5.0	4.5	5.0	5.0	
Lane Util. Factor	1.00	*0.75		0.97	0.91	1.00		1.00	1.00	0.97	1.00	
Frbp, ped/bikes	1.00	1.00		1.00	1.00	0.96		1.00	1.00	1.00	0.97	
Flpb, ped/bikes	1.00	1.00		1.00	1.00	1.00		1.00	1.00	1.00	1.00	
Frt	1.00	1.00		1.00	1.00	0.85		1.00	0.85	1.00	0.88	
Flt Protected	0.95	1.00		0.95	1.00	1.00		0.96	1.00	0.95	1.00	
Satd. Flow (prot)	1805	4100		3502	4988	1545		1786	1599	3502	1622	
Flt Permitted	0.95	1.00		0.95	1.00	1.00		0.96	1.00	0.95	1.00	
Satd. Flow (perm)	1805	4100		3502	4988	1545		1786	1599	3502	1622	
Peak-hour factor, PHF	0.98	0.98	0.98	0.98	0.98	0.98	0.98	0.98	0.98	0.98	0.98	0.98
Adj. Flow (vph)	101	1938	41	237	1729	256	37	10	241	330	24	115
RTOR Reduction (vph)	0	1	0	0	0	126	0	0	0	0	99	0
Lane Group Flow (vph)	101	1978	0	237	1729	130	0	47	241	330	40	0
Confl. Peds. (#/hr)			2			8						15
Heavy Vehicles (%)	0%	4%	0%	0%	4%	0%	3%	0%	1%	0%	0%	0%
Turn Type	Prot			Prot		Perm	Split		pt+ov	Split		
Protected Phases	5	2		1	6		8	8	18	4	4	
Permitted Phases						6						
Actuated Green, G (s)	14.1	61.1		16.1	63.1	63.1		8.6	24.7	16.7	16.7	
Effective Green, g (s)	14.6	61.6		16.6	63.6	63.6		9.1	25.7	17.2	17.2	
Actuated g/C Ratio	0.12	0.49		0.13	0.51	0.51		0.07	0.21	0.14	0.14	
Clearance Time (s)	5.0	6.5		5.0	6.5	6.5		5.5		5.5	5.5	
Vehicle Extension (s)	2.5	4.0		2.5	4.0	4.0		2.5		2.5	2.5	
Lane Grp Cap (vph)	211	2020		465	2538	786		130	329	482	223	
v/s Ratio Prot	0.06	c0.48		0.07	0.35			0.03	c0.15	c0.09	0.02	
v/s Ratio Perm						0.08						
v/c Ratio	0.48	0.98		0.51	0.68	0.17		0.36	0.73	0.68	0.18	
Uniform Delay, d1	51.6	31.1		50.4	23.1	16.5		55.2	46.4	51.3	47.7	
Progression Factor	0.88	0.56		1.04	0.86	1.12		1.00	1.00	1.00	1.00	
Incremental Delay, d2	0.6	9.4		0.4	1.0	0.3		1.2	7.7	3.7	0.3	
Delay (s)	46.2	26.6		53.0	20.9	18.7		56.4	54.2	55.0	47.9	
Level of Service	D	C		D	C	B		E	D	D	D	
Approach Delay (s)		27.6			24.1			54.5			52.9	
Approach LOS		C			C			D			D	
Intersection Summary												
HCM Average Control Delay			29.9			HCM Level of Service				C		
HCM Volume to Capacity ratio			0.83									
Actuated Cycle Length (s)			125.0			Sum of lost time (s)			15.5			
Intersection Capacity Utilization			81.5%			ICU Level of Service				D		
Analysis Period (min)			15									
c Critical Lane Group												

HCM Signalized Intersection Capacity Analysis

12: Tualatin Sherwood Rd & I-5 SB Ramps

4/15/2013













												
Movement	EBL	EBT	EBR	WBL	WBT	WBR	NBL	NBT	NBR	SBL	SBT	SBR
Lane Configurations		↑↑↑	↗	↖	↑↑					↖	↗	↗↗
Volume (vph)	0	1590	875	123	1063	0	0	0	0	659	5	1111
Ideal Flow (vphpl)	1900	1900	1900	1900	1900	1900	1900	1900	1900	1900	1900	1900
Total Lost time (s)		5.5	5.5	5.5	5.5					5.5	5.5	5.5
Lane Util. Factor		*0.75	1.00	1.00	0.95					0.95	0.95	0.88
Flt		1.00	0.85	1.00	1.00					1.00	1.00	0.85
Flt Protected		1.00	1.00	0.95	1.00					0.95	0.95	1.00
Satd. Flow (prot)		4150	1568	1787	3471					1681	1682	2760
Flt Permitted		1.00	1.00	0.95	1.00					0.95	0.95	1.00
Satd. Flow (perm)		4150	1568	1787	3471					1681	1682	2760
Peak-hour factor, PHF	0.99	0.99	0.99	0.99	0.99	0.99	0.99	0.99	0.99	0.99	0.99	0.99
Adj. Flow (vph)	0	1606	884	124	1074	0	0	0	0	666	5	1122
RTOR Reduction (vph)	0	0	476	0	0	0	0	0	0	0	0	23
Lane Group Flow (vph)	0	1606	408	124	1074	0	0	0	0	333	338	1099
Heavy Vehicles (%)	0%	3%	3%	1%	4%	0%	0%	0%	0%	2%	20%	3%
Turn Type			Perm	Prot						Split		custom
Protected Phases		2		1	6					4	4	4.5
Permitted Phases			2									
Actuated Green, G (s)		56.5	56.5	11.1	51.5					39.4	39.4	61.5
Effective Green, g (s)		57.0	57.0	11.6	52.0					39.9	39.9	62.0
Actuated g/C Ratio		0.46	0.46	0.09	0.42					0.32	0.32	0.50
Clearance Time (s)		6.0	6.0	6.0	6.0					6.0	6.0	
Vehicle Extension (s)		6.1	6.1	2.3	6.1					2.3	2.3	
Lane Grp Cap (vph)		1892	715	166	1444					537	537	1369
v/s Ratio Prot		c0.39		0.07	c0.31					0.20	0.20	c0.40
v/s Ratio Perm			0.26									
v/c Ratio		0.85	0.57	0.75	0.74					0.62	0.63	0.80
Uniform Delay, d1		30.2	25.0	55.3	30.9					36.1	36.3	26.4
Progression Factor		0.50	2.46	0.79	0.64					1.00	1.00	1.00
Incremental Delay, d2		2.5	1.6	14.5	3.3					1.8	1.9	3.4
Delay (s)		17.6	63.1	58.3	23.1					37.9	38.1	29.8
Level of Service		B	E	E	C					D	D	C
Approach Delay (s)		33.7			26.8			0.0			32.8	
Approach LOS		C			C			A			C	
Intersection Summary												
HCM Average Control Delay			31.9			HCM Level of Service				C		
HCM Volume to Capacity ratio			0.82									
Actuated Cycle Length (s)			125.0			Sum of lost time (s)				11.0		
Intersection Capacity Utilization			93.1%			ICU Level of Service				F		
Analysis Period (min)			15									

c Critical Lane Group

HCM Signalized Intersection Capacity Analysis





















13: Tualatin Sherwood Rd & I-5 NB Ramps

4/15/2013

												
Movement	EBL	EBT	EBR	WBL	WBT	WBR	NBL	NBT	NBR	SBL	SBT	SBR
Lane Configurations		↑↑	↑↑		↑↑	↑	↑	↑	↑			
Volume (vph)	0	1216	1031	0	511	682	675	5	177	0	0	0
Ideal Flow (vphpl)	1900	1900	1900	1900	1900	1900	1900	1900	1900	1900	1900	1900
Total Lost time (s)		5.5	5.5		6.0	6.0	5.5	5.5	5.5			
Lane Util. Factor		0.95	0.88		0.95	1.00	0.95	0.95	1.00			
Frbp, ped/bikes		1.00	1.00		1.00	0.95	1.00	1.00	0.96			
Flpb, ped/bikes		1.00	1.00		1.00	1.00	1.00	1.00	1.00			
Frt		1.00	0.85		1.00	0.85	1.00	1.00	0.85			
Flt Protected		1.00	1.00		1.00	1.00	0.95	0.95	1.00			
Satd. Flow (prot)		3574	2760		3574	1502	1618	1620	1512			
Flt Permitted		1.00	1.00		1.00	1.00	0.95	0.95	1.00			
Satd. Flow (perm)		3574	2760		3574	1502	1618	1620	1512			
Peak-hour factor, PHF	0.95	0.95	0.95	0.95	0.95	0.95	0.95	0.95	0.95	0.95	0.95	0.95
Adj. Flow (vph)	0	1280	1085	0	538	718	711	5	186	0	0	0
RTOR Reduction (vph)	0	0	352	0	0	263	0	0	21	0	0	0
Lane Group Flow (vph)	0	1280	733	0	538	455	355	361	165	0	0	0
Confl. Peds. (#/hr)						16			17			
Heavy Vehicles (%)	0%	1%	3%	0%	1%	2%	6%	20%	2%	0%	0%	0%
Turn Type			Perm			Perm	Split		Perm			
Protected Phases		2			6		8	8				
Permitted Phases			2			6			8			
Actuated Green, G (s)		79.3	79.3		78.8	78.8	33.7	33.7	33.7			
Effective Green, g (s)		79.8	79.8		79.3	79.3	34.2	34.2	34.2			
Actuated g/C Ratio		0.64	0.64		0.63	0.63	0.27	0.27	0.27			
Clearance Time (s)		6.0	6.0		6.5	6.5	6.0	6.0	6.0			
Vehicle Extension (s)		6.1	6.1		4.2	4.2	2.3	2.3	2.3			
Lane Grp Cap (vph)		2282	1762		2267	953	443	443	414			
v/s Ratio Prot		c0.36			0.15		0.22	c0.22				
v/s Ratio Perm			0.27			0.30			0.11			
v/c Ratio		0.56	0.42		0.24	0.48	0.80	0.81	0.40			
Uniform Delay, d1		12.7	11.1		9.8	12.0	42.2	42.4	37.0			
Progression Factor		0.72	1.20		1.00	1.00	1.00	1.00	1.00			
Incremental Delay, d2		0.7	0.5		0.2	1.7	9.6	10.6	0.4			
Delay (s)		9.9	13.8		10.1	13.7	51.9	53.1	37.4			
Level of Service		A	B		B	B	D	D	D			
Approach Delay (s)		11.7			12.2			49.4			0.0	
Approach LOS		B			B			D			A	
Intersection Summary												
HCM Average Control Delay			19.3									B
HCM Volume to Capacity ratio			0.64									
Actuated Cycle Length (s)			125.0						11.0			
Intersection Capacity Utilization			72.2%									C
Analysis Period (min)			15									
c Critical Lane Group												





















HCM Signalized Intersection Capacity Analysis
 14: Tualatin Sherwood Rd & Nyberg Woods

4/15/2013

												
Movement	EBL	EBT	EBR	WBL	WBT	WBR	NBL	NBT	NBR	SBL	SBT	SBR
Lane Configurations												
Volume (vph)	290	995	61	10	834	80	112	7	17	81	5	191
Ideal Flow (vphpl)	1900	1900	1900	1900	1900	1900	1900	1900	1900	1900	1900	1900
Total Lost time (s)	5.5	5.5		5.5	5.5			5.5	5.5		5.5	5.5
Lane Util. Factor	0.97	0.95		1.00	0.95			1.00	1.00		1.00	1.00
Frbp, ped/bikes	1.00	1.00		1.00	1.00			1.00	0.98		1.00	0.99
Flpb, ped/bikes	1.00	1.00		1.00	1.00			1.00	1.00		1.00	1.00
Frt	1.00	0.99		1.00	0.99			1.00	0.85		1.00	0.85
Flt Protected	0.95	1.00		0.95	1.00			0.95	1.00		0.95	1.00
Satd. Flow (prot)	3502	3504		1805	3525			1761	1590		1793	1592
Flt Permitted	0.95	1.00		0.95	1.00			0.67	1.00		0.65	1.00
Satd. Flow (perm)	3502	3504		1805	3525			1243	1590		1221	1592
Peak-hour factor, PHF	0.96	0.96	0.96	0.96	0.96	0.96	0.96	0.96	0.96	0.96	0.96	0.96
Adj. Flow (vph)	302	1036	64	10	869	83	117	7	18	84	5	199
RTOR Reduction (vph)	0	3	0	0	7	0	0	0	15	0	0	165
Lane Group Flow (vph)	302	1097	0	10	945	0	0	124	3	0	89	34
Confl. Peds. (#/hr)	9		2	2		9	3		4	4		3
Heavy Vehicles (%)	0%	2%	2%	0%	1%	0%	3%	0%	0%	1%	0%	0%
Turn Type	Prot			Prot			Perm		Perm	Perm		Perm
Protected Phases	5	2		1	6			8				4
Permitted Phases							8		8	4		4
Actuated Green, G (s)	9.0	33.1		0.7	24.8			10.2	10.2		10.2	10.2
Effective Green, g (s)	9.5	33.6		1.2	25.3			10.7	10.7		10.7	10.7
Actuated g/C Ratio	0.15	0.54		0.02	0.41			0.17	0.17		0.17	0.17
Clearance Time (s)	6.0	6.0		6.0	6.0			6.0	6.0		6.0	6.0
Vehicle Extension (s)	2.3	2.5		2.4	2.5			2.4	2.4		2.3	2.3
Lane Grp Cap (vph)	537	1899		35	1438			215	274		211	275
v/s Ratio Prot	c0.09	c0.31		0.01	c0.27							
v/s Ratio Perm								c0.10	0.00		0.07	0.02
v/c Ratio	0.56	0.58		0.29	0.66			0.58	0.01		0.42	0.12
Uniform Delay, d1	24.3	9.5		30.0	14.8			23.6	21.3		22.9	21.7
Progression Factor	1.00	1.00		1.00	1.00			1.00	1.00		1.00	1.00
Incremental Delay, d2	1.0	0.4		2.9	1.0			2.9	0.0		0.8	0.1
Delay (s)	25.3	9.8		32.9	15.8			26.5	21.3		23.7	21.8
Level of Service	C	A		C	B			C	C		C	C
Approach Delay (s)		13.2			16.0			25.8			22.4	
Approach LOS		B			B			C			C	
Intersection Summary												
HCM Average Control Delay			15.7			HCM Level of Service			B			
HCM Volume to Capacity ratio			0.71									
Actuated Cycle Length (s)			62.0			Sum of lost time (s)		22.0				
Intersection Capacity Utilization			61.6%			ICU Level of Service		B				
Analysis Period (min)			15									
c Critical Lane Group												



























HCM Signalized Intersection Capacity Analysis
 15: SW Nyberg St & SW Nyberg St

4/15/2013

												
Movement	EBL	EBT	EBR	WBL	WBT	WBR	NBL	NBT	NBR	SBL	SBT	SBR
Lane Configurations												
Volume (vph)	221	943	26	24	775	16	17	9	45	5	7	139
Ideal Flow (vphpl)	1900	1900	1900	1900	1900	1900	1900	1900	1900	1900	1900	1900
Total Lost time (s)	4.8	4.8		4.8	4.8			5.6	5.6		5.3	4.8
Lane Util. Factor	1.00	1.00		1.00	0.95			1.00	1.00		1.00	1.00
Frbp, ped/bikes	1.00	1.00		1.00	1.00			1.00	0.95		1.00	1.00
Flpb, ped/bikes	1.00	1.00		1.00	1.00			1.00	1.00		1.00	1.00
Frt	1.00	1.00		1.00	1.00			1.00	0.85		1.00	0.85
Flt Protected	0.95	1.00		0.95	1.00			0.97	1.00		0.98	1.00
Satd. Flow (prot)	1805	1854		1805	3561			1803	1527		1848	1609
Flt Permitted	0.95	1.00		0.95	1.00			0.97	1.00		0.69	1.00
Satd. Flow (perm)	1805	1854		1805	3561			1803	1527		1304	1609
Peak-hour factor, PHF	0.96	0.96	0.96	0.96	0.96	0.96	0.96	0.96	0.96	0.96	0.96	0.96
Adj. Flow (vph)	230	982	27	25	807	17	18	9	47	5	7	145
RTOR Reduction (vph)	0	0	0	0	1	0	0	0	44	0	0	116
Lane Group Flow (vph)	230	1009	0	25	823	0	0	27	3	0	12	29
Confl. Peds. (#/hr)	9		2	2		9	3		4	4		3
Heavy Vehicles (%)	0%	2%	2%	0%	1%	0%	3%	0%	0%	1%	0%	0%
Turn Type	Prot			Prot			Split		Perm	Perm		pm+ov
Protected Phases	5	2		1	6		8	8			4	5
Permitted Phases									8	4		4
Actuated Green, G (s)	11.5	48.8		1.7	39.0			4.1	4.1		3.6	15.1
Effective Green, g (s)	12.0	49.3		2.2	39.5			4.6	4.6		4.1	16.1
Actuated g/C Ratio	0.15	0.61		0.03	0.49			0.06	0.06		0.05	0.20
Clearance Time (s)	5.3	5.3		5.3	5.3			6.1	6.1		5.8	5.3
Vehicle Extension (s)	2.5	3.0		1.0	3.0			1.0	1.0		2.0	2.5
Lane Grp Cap (vph)	268	1133		49	1743			103	87		66	321
v/s Ratio Prot	c0.13	c0.54		0.01	0.23			c0.01				0.01
v/s Ratio Perm									0.00		c0.01	0.00
v/c Ratio	0.86	0.89		0.51	0.47			0.26	0.03		0.18	0.09
Uniform Delay, d1	33.5	13.4		38.7	13.7			36.4	35.9		36.7	26.3
Progression Factor	1.00	1.00		1.00	1.00			1.00	1.00		1.00	1.00
Incremental Delay, d2	22.5	9.0		3.7	0.2			0.5	0.1		0.5	0.1
Delay (s)	56.1	22.4		42.4	13.9			36.9	36.0		37.2	26.4
Level of Service	E	C		D	B			D	D		D	C
Approach Delay (s)		28.6			14.7			36.3			27.2	
Approach LOS		C			B			D			C	
Intersection Summary												
HCM Average Control Delay			23.7			HCM Level of Service			C			
HCM Volume to Capacity ratio			0.83									
Actuated Cycle Length (s)			80.7			Sum of lost time (s)		20.5				
Intersection Capacity Utilization			76.8%			ICU Level of Service		D				
Analysis Period (min)			15									
c Critical Lane Group												























HCM Signalized Intersection Capacity Analysis
 16: SW Tualatin Sherwood Rd & SW Boones Ferry Rd

4/15/2013

												
Movement	EBL	EBT	EBR	WBL	WBT	WBR	NBL	NBT	NBR	SBL	SBT	SBR
Lane Configurations		 		 	 						 	
Volume (vph)	103	1035	138	234	1103	56	171	268	169	297	345	133
Ideal Flow (vphpl)	1900	1900	1900	1900	1900	1900	1900	1900	1900	1900	1900	1900
Total Lost time (s)	4.5	5.5		4.5	5.5		4.5	5.0	4.5	4.5	5.0	
Lane Util. Factor	1.00	0.95		0.97	0.95		1.00	1.00	1.00	1.00	0.95	
Frbp, ped/bikes	1.00	1.00		1.00	1.00		1.00	1.00	0.98	1.00	0.99	
Flpb, ped/bikes	1.00	1.00		1.00	1.00		1.00	1.00	1.00	1.00	1.00	
Frt	1.00	0.98		1.00	0.99		1.00	1.00	0.85	1.00	0.96	
Flt Protected	0.95	1.00		0.95	1.00		0.95	1.00	1.00	0.95	1.00	
Satd. Flow (prot)	1703	3320		3502	3339		1732	1810	1543	1761	3313	
Flt Permitted	0.95	1.00		0.95	1.00		0.41	1.00	1.00	0.59	1.00	
Satd. Flow (perm)	1703	3320		3502	3339		744	1810	1543	1099	3313	
Peak-hour factor, PHF	0.99	0.99	0.99	0.99	0.99	0.99	0.99	0.99	0.99	0.99	0.99	0.99
Adj. Flow (vph)	104	1045	139	236	1114	57	173	271	171	300	348	134
RTOR Reduction (vph)	0	7	0	0	3	0	0	0	55	0	34	0
Lane Group Flow (vph)	104	1177	0	236	1168	0	173	271	116	300	448	0
Confl. Peds. (#/hr)			7			15	7		8	8		7
Heavy Vehicles (%)	6%	7%	3%	0%	7%	6%	4%	5%	3%	2%	4%	3%
Turn Type	Prot			Prot			pm+pt		pm+ov		pm+pt	
Protected Phases	5	2		1	6		3	8	1	7	4	
Permitted Phases							8		8	4		
Actuated Green, G (s)	10.0	54.6		10.7	55.3		21.2	21.2	31.9	27.3	26.8	
Effective Green, g (s)	10.5	55.1		11.2	55.8		21.7	21.7	32.9	27.8	27.3	
Actuated g/C Ratio	0.08	0.44		0.09	0.45		0.17	0.17	0.26	0.22	0.22	
Clearance Time (s)	5.0	6.0		5.0	6.0		5.0	5.5	5.0	5.0	5.5	
Vehicle Extension (s)	2.0	3.5		2.0	3.5		2.0	2.0	2.0	2.0	2.0	
Lane Grp Cap (vph)	143	1463		314	1491		223	314	406	337	724	
v/s Ratio Prot	0.06	c0.35		0.07	c0.35		0.07	c0.15	0.03	c0.12	0.14	
v/s Ratio Perm							0.06		0.05	c0.07		
v/c Ratio	0.73	0.80		0.75	0.78		0.78	0.86	0.29	0.89	0.62	
Uniform Delay, d1	55.9	30.3		55.5	29.5		47.6	50.2	36.7	45.8	44.1	
Progression Factor	1.00	1.00		0.61	0.96		1.00	1.00	1.00	1.00	1.00	
Incremental Delay, d2	14.4	4.8		5.3	2.5		14.2	20.3	0.1	23.5	1.1	
Delay (s)	70.3	35.1		39.2	30.9		61.8	70.5	36.8	69.4	45.3	
Level of Service	E	D		D	C		E	E	D	E	D	
Approach Delay (s)		37.9			32.3			58.7			54.5	
Approach LOS		D			C			E			D	
Intersection Summary												
HCM Average Control Delay			42.3			HCM Level of Service				D		
HCM Volume to Capacity ratio			0.87									
Actuated Cycle Length (s)			125.0			Sum of lost time (s)			20.5			
Intersection Capacity Utilization			88.2%			ICU Level of Service			E			
Analysis Period (min)			15									
c Critical Lane Group												



















HCM Signalized Intersection Capacity Analysis
 17: Tualatin Sherwood Rd & Martinazzi Ave

4/15/2013

												
Movement	EBL	EBT	EBR	WBL	WBT	WBR	NBL	NBT	NBR	SBL	SBT	SBR
Lane Configurations		 			 						 	
Volume (vph)	55	1515	83	0	1146	0	95	312	333	194	673	90
Ideal Flow (vphpl)	1900	1900	1900	1900	1900	1900	1900	1900	1900	1900	1900	1900
Total Lost time (s)	4.5	5.5			5.5		4.5	5.5	5.5	4.5	5.5	
Lane Util. Factor	1.00	0.95			0.95		1.00	1.00	1.00	1.00	0.95	
Frbp, ped/bikes	1.00	1.00			1.00		1.00	1.00	0.98	1.00	1.00	
Flpb, ped/bikes	1.00	1.00			1.00		1.00	1.00	1.00	1.00	1.00	
Frt	1.00	0.99			1.00		1.00	1.00	0.85	1.00	0.98	
Flt Protected	0.95	1.00			1.00		0.95	1.00	1.00	0.95	1.00	
Satd. Flow (prot)	1719	3448			3438		1770	1863	1574	1787	3497	
Flt Permitted	0.95	1.00			1.00		0.95	1.00	1.00	0.95	1.00	
Satd. Flow (perm)	1719	3448			3438		1770	1863	1574	1787	3497	
Peak-hour factor, PHF	0.94	0.94	0.94	0.94	0.94	0.94	0.94	0.94	0.94	0.94	0.94	0.94
Adj. Flow (vph)	59	1612	88	0	1219	0	101	332	354	206	716	96
RTOR Reduction (vph)	0	3	0	0	0	0	0	0	80	0	10	0
Lane Group Flow (vph)	59	1697	0	0	1219	0	101	332	274	206	802	0
Confl. Peds. (#/hr)			4				2		3			16
Heavy Vehicles (%)	5%	4%	0%	0%	5%	0%	2%	2%	1%	1%	1%	1%
Turn Type	Prot						Prot		Perm	Prot		
Protected Phases	5	2			6		3	8		7	4	
Permitted Phases									8			
Actuated Green, G (s)	7.2	65.2			53.0		9.9	24.1	24.1	18.7	32.9	
Effective Green, g (s)	7.7	65.7			53.5		10.4	24.6	24.6	19.2	33.4	
Actuated g/C Ratio	0.06	0.53			0.43		0.08	0.20	0.20	0.15	0.27	
Clearance Time (s)	5.0	6.0			6.0		5.0	6.0	6.0	5.0	6.0	
Vehicle Extension (s)	2.0	3.5			3.5		3.0	2.0	2.0	3.0	2.0	
Lane Grp Cap (vph)	106	1812			1471		147	367	310	274	934	
v/s Ratio Prot	0.03	c0.49			0.35		0.06	c0.18		0.12	c0.23	
v/s Ratio Perm									0.17			
v/c Ratio	0.56	0.94			0.83		0.69	0.90	0.88	0.75	0.86	
Uniform Delay, d1	57.0	27.7			31.7		55.7	49.1	48.8	50.6	43.6	
Progression Factor	1.20	0.74			1.09		1.00	1.00	1.00	1.00	1.00	
Incremental Delay, d2	2.7	8.5			4.4		12.5	24.3	23.7	11.0	7.7	
Delay (s)	70.9	29.0			38.9		68.3	73.4	72.5	61.7	51.2	
Level of Service	E	C			D		E	E	E	E	D	
Approach Delay (s)		30.4			38.9			72.3			53.3	
Approach LOS		C			D			E			D	
Intersection Summary												
HCM Average Control Delay			44.4				HCM Level of Service			D		
HCM Volume to Capacity ratio			0.89									
Actuated Cycle Length (s)			125.0				Sum of lost time (s)		11.0			
Intersection Capacity Utilization			89.5%				ICU Level of Service		E			
Analysis Period (min)			15									
c Critical Lane Group												





















HCM Signalized Intersection Capacity Analysis
 18: SW Borland Rd & SW 65th Ave

4/15/2013

												
Movement	EBL	EBT	EBR	WBL	WBT	WBR	NBL	NBT	NBR	SBL	SBT	SBR
Lane Configurations												
Volume (vph)	23	23	10	240	0	244	2	334	369	433	474	10
Ideal Flow (vphpl)	1900	1900	1900	1900	1900	1900	1900	1900	1900	1900	1900	1900
Total Lost time (s)		5.6			5.3	5.6	4.8	4.8		4.8	4.8	
Lane Util. Factor		1.00			1.00	1.00	1.00	1.00		1.00	1.00	
Frbp, ped/bikes		0.99			1.00	0.90	1.00	0.98		1.00	1.00	
Flpb, ped/bikes		1.00			1.00	1.00	1.00	1.00		1.00	1.00	
Frt		0.98			1.00	0.85	1.00	0.92		1.00	1.00	
Flt Protected		0.98			0.95	1.00	0.95	1.00		0.95	1.00	
Satd. Flow (prot)		1785			1805	1456	1748	1719		1787	1893	
Flt Permitted		0.98			0.95	1.00	0.48	1.00		0.08	1.00	
Satd. Flow (perm)		1785			1805	1456	880	1719		157	1893	
Peak-hour factor, PHF	0.96	0.96	0.96	0.96	0.96	0.96	0.96	0.96	0.96	0.96	0.96	0.96
Adj. Flow (vph)	24	24	10	250	0	254	2	348	384	451	494	10
RTOR Reduction (vph)	0	6	0	0	0	240	0	25	0	0	0	0
Lane Group Flow (vph)	0	52	0	0	250	14	2	707	0	451	504	0
Confl. Peds. (#/hr)	9		2	2		9	3		4	4		3
Heavy Vehicles (%)	0%	2%	2%	0%	1%	0%	3%	0%	0%	1%	0%	0%
Turn Type	Split			Split		custom	pm+pt			pm+pt		
Protected Phases	8	8		4	4		1	6		5	2	
Permitted Phases						8	6			2		
Actuated Green, G (s)		7.6			20.0	7.6	65.3	64.3		99.6	93.3	
Effective Green, g (s)		8.1			20.5	8.1	66.3	64.8		100.1	93.8	
Actuated g/C Ratio		0.06			0.14	0.06	0.46	0.45		0.69	0.65	
Clearance Time (s)		6.1			5.8	6.1	5.3	5.3		5.3	5.3	
Vehicle Extension (s)		1.0			2.0	1.0	1.0	3.0		2.5	0.2	
Lane Grp Cap (vph)		100			256	82	413	771		453	1230	
v/s Ratio Prot		c0.03			c0.14		0.00	0.41		c0.21	0.27	
v/s Ratio Perm						0.01	0.00			c0.48		
v/c Ratio		0.52			0.98	0.17	0.00	0.92		1.00	0.41	
Uniform Delay, d1		66.3			61.7	65.0	21.1	37.3		45.6	12.1	
Progression Factor		1.00			1.00	1.00	1.00	1.00		1.00	1.00	
Incremental Delay, d2		2.3			49.0	0.4	0.0	15.5		40.9	0.1	
Delay (s)		68.5			110.8	65.3	21.1	52.8		86.5	12.2	
Level of Service		E			F	E	C	D		F	B	
Approach Delay (s)		68.5			87.9			52.7			47.2	
Approach LOS		E			F			D			D	
Intersection Summary												
HCM Average Control Delay			58.7									HCM Level of Service E
HCM Volume to Capacity ratio			0.95									
Actuated Cycle Length (s)			144.4									Sum of lost time (s) 15.7
Intersection Capacity Utilization			96.8%									ICU Level of Service F
Analysis Period (min)			15									
c Critical Lane Group												

HCM Signalized Intersection Capacity Analysis
 19: SW Sagert St & SW Boones Ferry Rd

4/15/2013

													
Movement	EBL	EBT	EBR	WBL	WBT	WBR	NBL	NBT	NBR	SBL	SBT	SBR	
Lane Configurations													
Volume (vph)	42	117	13	166	122	64	16	486	218	65	571	75	
Ideal Flow (vphpl)	1900	1900	1900	1900	1900	1900	1900	1900	1900	1900	1900	1900	
Total Lost time (s)	3.5	3.5		3.5	3.5		3.5	4.0		3.5	4.0		
Lane Util. Factor	1.00	1.00		1.00	1.00		1.00	1.00		1.00	1.00		
Frbp, ped/bikes	1.00	1.00		1.00	0.98		1.00	0.99		1.00	1.00		
Flpb, ped/bikes	0.99	1.00		1.00	1.00		1.00	1.00		1.00	1.00		
Frt	1.00	0.98		1.00	0.95		1.00	0.95		1.00	0.98		
Flt Protected	0.95	1.00		0.95	1.00		0.95	1.00		0.95	1.00		
Satd. Flow (prot)	1782	1830		1781	1739		1769	1789		1804	1860		
Flt Permitted	0.64	1.00		0.42	1.00		0.25	1.00		0.17	1.00		
Satd. Flow (perm)	1191	1830		785	1739		468	1789		319	1860		
Peak-hour factor, PHF	0.95	0.95	0.95	0.95	0.95	0.95	0.95	0.95	0.95	0.95	0.95	0.95	
Adj. Flow (vph)	44	123	14	175	128	67	17	512	229	68	601	79	
RTOR Reduction (vph)	0	4	0	0	16	0	0	11	0	0	3	0	
Lane Group Flow (vph)	44	133	0	175	179	0	17	730	0	68	677	0	
Confl. Peds. (#/hr)	15		7	7		15	7		8	8		7	
Heavy Vehicles (%)	0%	2%	1%	1%	3%	0%	2%	0%	1%	0%	0%	0%	
Turn Type	pm+pt		pm+pt			pm+pt			pm+pt				
Protected Phases	7	4		3	8		5	2		1	6		
Permitted Phases	4			8			2			6			
Actuated Green, G (s)	15.3	12.4		25.7	18.8		47.1	45.6		51.5	47.8		
Effective Green, g (s)	16.3	12.9		26.2	19.3		48.1	46.1		52.5	48.3		
Actuated g/C Ratio	0.19	0.15		0.30	0.22		0.55	0.53		0.60	0.55		
Clearance Time (s)	4.0	4.0		4.0	4.0		4.0	4.5		4.0	4.5		
Vehicle Extension (s)	2.2	2.2		2.2	2.2		2.2	5.0		2.2	5.0		
Lane Grp Cap (vph)	245	270		347	384		287	943		263	1027		
v/s Ratio Prot	0.01	0.07		c0.06	0.10		0.00	c0.41		c0.01	0.36		
v/s Ratio Perm	0.03			c0.09			0.03			0.14			
v/c Ratio	0.18	0.49		0.50	0.47		0.06	0.77		0.26	0.66		
Uniform Delay, d1	29.7	34.3		24.1	29.6		10.8	16.5		11.9	13.8		
Progression Factor	1.00	1.00		1.00	1.00		1.00	1.00		1.00	1.00		
Incremental Delay, d2	0.2	0.7		0.6	0.5		0.0	4.7		0.3	2.1		
Delay (s)	29.9	35.0		24.7	30.1		10.8	21.2		12.2	15.9		
Level of Service	C	D		C	C		B	C		B	B		
Approach Delay (s)		33.8			27.5			21.0			15.5		
Approach LOS		C			C			C			B		
Intersection Summary													
HCM Average Control Delay			21.3			HCM Level of Service				C			
HCM Volume to Capacity ratio			0.68										
Actuated Cycle Length (s)			87.5			Sum of lost time (s)			14.5				
Intersection Capacity Utilization			74.8%			ICU Level of Service				D			
Analysis Period (min)			15										
c Critical Lane Group													

Intersection: 12: Tualatin Sherwood Rd & I-5 SB Ramps

Movement	EB	EB	EB	EB	WB	WB	WB	SB	SB	SB	SB
Directions Served	T	T	T	R	L	T	T	L	LT	R	R
Maximum Queue (ft)	410	477	487	381	515	642	679	225	801	538	436
Average Queue (ft)	190	187	192	61	167	391	435	177	393	280	209
95th Queue (ft)	352	369	372	232	422	641	680	267	703	449	373
Link Distance (ft)	507	507	507		641	641	641		1156	1156	
Upstream Blk Time (%)	0	0	1		1	2	3				
Queuing Penalty (veh)	1	3	4		2	9	13				
Storage Bay Dist (ft)				400				200			700
Storage Blk Time (%)			1	0				6	23	0	
Queuing Penalty (veh)			6	0				21	77	0	

Intersection: 13: Tualatin Sherwood Rd & I-5 NB Ramps

Movement	EB	EB	EB	EB	WB	WB	WB	NB	NB	NB
Directions Served	T	T	R	R	T	T	R	L	LT	R
Maximum Queue (ft)	634	555	111	105	194	328	223	357	652	300
Average Queue (ft)	336	215	11	7	83	119	18	237	295	121
95th Queue (ft)	589	466	146	110	164	235	116	350	628	267
Link Distance (ft)	641	641	641	641	478	478			1328	
Upstream Blk Time (%)	1	0	0	0		0			0	
Queuing Penalty (veh)	7	1	0	0		1			0	
Storage Bay Dist (ft)							150	300		225
Storage Blk Time (%)						3	0	3	13	0
Queuing Penalty (veh)						21	0	16	67	3

Phone:
E-Mail:

Fax:

ALL-WAY STOP CONTROL (AWSC) ANALYSIS

Analyst:
Agency/Co.:
Date Performed: 4/16/2013
Analysis Time Period: Weekday PM
Intersection: Sagert/Martinazzi
Jurisdiction:
Units: U. S. Customary
Analysis Year: Total
Project ID:
East/West Street: Sagert
North/South Street: Martinazzi

Worksheet 2 - Volume Adjustments and Site Characteristics

	Eastbound			Westbound			Northbound			Southbound		
	L	T	R	L	T	R	L	T	R	L	T	R
Volume	127	233	12	90	195	164	2		76	207	306	0
% Thrus Left Lane												

	Eastbound		Westbound		Northbound		Southbound	
	L1	L2	L1	L2	L1	L2	L1	L2
Configuration	L	TR	L	TR	L	TR	L	TR
PHF	0.90	0.90	0.90	0.90	0.90	0.90	0.90	0.90
Flow Rate	141	271	100	398	2	284	230	340
% Heavy Veh	1	1	1	1	1	1	1	1
No. Lanes		2		2		2		2
Opposing-Lanes		2		2		2		2
Conflicting-lanes		2		2		2		2
Geometry group		5		5		5		5
Duration, T	0.25 hrs.							

Worksheet 3 - Saturation Headway Adjustment Worksheet

	Eastbound		Westbound		Northbound		Southbound	
	L1	L2	L1	L2	L1	L2	L1	L2
Flow Rates:								
Total in Lane	141	271	100	398	2	284	230	340
Left-Turn	141	0	100	0	2	0	230	0
Right-Turn	0	13	0	182	0	84	0	0
Prop. Left-Turns	1.0	0.0	1.0	0.0	1.0	0.0	1.0	0.0
Prop. Right-Turns	0.0	0.0	0.0	0.5	0.0	0.3	0.0	0.0
Prop. Heavy Vehicle	0.0	0.0	0.0	0.0	0.0	0.0	0.0	0.0
Geometry Group		5		5		5		5
Adjustments Exhibit 17-33:								
hLT-adj		0.5		0.5		0.5		0.5

hRT-adj	-0.7		-0.7		-0.7		-0.7	
hHV-adj	1.7		1.7		1.7		1.7	
hadj, computed	0.5	-0.0	0.5	-0.3	0.5	-0.2	0.5	0.0

Worksheet 4 - Departure Headway and Service Time

	Eastbound		Westbound		Northbound		Southbound	
	L1	L2	L1	L2	L1	L2	L1	L2
Flow rate	141	271	100	398	2	284	230	340
hd, initial value	3.20	3.20	3.20	3.20	3.20	3.20	3.20	3.20
x, initial	0.13	0.24	0.09	0.35	0.00	0.25	0.20	0.30
hd, final value	8.96	8.42	8.76	7.94	9.19	8.48	8.72	8.22
x, final value	0.35	0.63	0.24	0.88	0.01	0.67	0.56	0.78
Move-up time, m		2.3		2.3		2.3		2.3
Service Time	6.7	6.1	6.5	5.6	6.9	6.2	6.4	5.9

Worksheet 5 - Capacity and Level of Service

	Eastbound		Westbound		Northbound		Southbound	
	L1	L2	L1	L2	L1	L2	L1	L2
Flow Rate	141	271	100	398	2	284	230	340
Service Time	6.7	6.1	6.5	5.6	6.9	6.2	6.4	5.9
Utilization, x	0.35	0.63	0.24	0.88	0.01	0.67	0.56	0.78
Dep. headway, hd	8.96	8.42	8.76	7.94	9.19	8.48	8.72	8.22
Capacity	391	418	350	450	252	413	407	433
Delay	16.42	24.61	14.25	45.54	11.93	26.70	21.85	34.14
LOS	C	C	B	E	B	D	C	D
Approach:								
Delay		21.81		39.26		26.59		29.18
LOS		C		E		D		D
Intersection Delay	29.88							

Phone:
E-Mail:

Fax:

ALL-WAY STOP CONTROL (AWSC) ANALYSIS

Analyst:
Agency/Co.:
Date Performed: 4/16/2013
Analysis Time Period: Weekday PM
Intersection: Sagert/65th
Jurisdiction:
Units: U. S. Customary
Analysis Year: Total
Project ID:
East/West Street: Sagert
North/South Street: 65th

Worksheet 2 - Volume Adjustments and Site Characteristics

	Eastbound			Westbound			Northbound			Southbound		
	L	T	R	L	T	R	L	T	R	L	T	R
Volume	401	2	135	2	7	6	58		3	3	340	386
% Thrus Left Lane												

	Eastbound		Westbound		Northbound		Southbound	
	L1	L2	L1	L2	L1	L2	L1	L2
Configuration	L	TR	L	TR	L	TR	L	TR
PHF	0.90	0.90	0.90	0.90	0.90	0.90	0.90	0.90
Flow Rate	445	152	2	13	64	323	3	805
% Heavy Veh	1	1	0	0	1	2	1	2
No. Lanes		2		2		2		2
Opposing-Lanes		2		2		2		2
Conflicting-lanes		2		2		2		2
Geometry group		5		5		5		5
Duration, T	0.25 hrs.							

Worksheet 3 - Saturation Headway Adjustment Worksheet

	Eastbound		Westbound		Northbound		Southbound	
	L1	L2	L1	L2	L1	L2	L1	L2
Flow Rates:								
Total in Lane	445	152	2	13	64	323	3	805
Left-Turn	445	0	2	0	64	0	3	0
Right-Turn	0	150	0	6	0	3	0	428
Prop. Left-Turns	1.0	0.0	1.0	0.0	1.0	0.0	1.0	0.0
Prop. Right-Turns	0.0	1.0	0.0	0.5	0.0	0.0	0.0	0.5
Prop. Heavy Vehicle	0.0	0.0	0.0	0.0	0.0	0.0	0.0	0.0
Geometry Group		5		5		5		5
Adjustments Exhibit 17-33:								
hLT-adj		0.5		0.5		0.5		0.5

hRT-adj	-0.7	-0.7	-0.7	-0.7
hHV-adj	1.7	1.7	1.7	1.7
hadj, computed	0.5	-0.7	0.5	-0.3

Worksheet 4 - Departure Headway and Service Time

	Eastbound		Westbound		Northbound		Southbound	
	L1	L2	L1	L2	L1	L2	L1	L2
Flow rate	445	152	2	13	64	323	3	805
hd, initial value	3.20	3.20	3.20	3.20	3.20	3.20	3.20	3.20
x, initial	0.40	0.14	0.00	0.01	0.06	0.29	0.00	0.72
hd, final value	7.73	6.54	9.23	8.40	8.00	7.51	7.77	6.92
x, final value	0.96	0.28	0.01	0.03	0.14	0.67	0.01	1.55
Move-up time, m		2.3		2.3		2.3		2.3
Service Time	5.4	4.2	6.9	6.1	5.7	5.2	5.5	4.6

Worksheet 5 - Capacity and Level of Service

	Eastbound		Westbound		Northbound		Southbound	
	L1	L2	L1	L2	L1	L2	L1	L2
Flow Rate	445	152	2	13	64	323	3	805
Service Time	5.4	4.2	6.9	6.1	5.7	5.2	5.5	4.6
Utilization, x	0.96	0.28	0.01	0.03	0.14	0.67	0.01	1.55
Dep. headway, hd	7.73	6.54	9.23	8.40	8.00	7.51	7.77	6.92
Capacity	466	402	252	263	314	475	253	805
Delay	58.85	11.71	11.98	11.37	12.02	24.33	10.52	273.87
LOS	F	B	B	B	B	C	B	F
Approach:								
Delay		46.85		11.45		22.29		272.89
LOS		E		B		C		F
Intersection Delay	142.37							

HCM Unsignalized Intersection Capacity Analysis
 22: SW Boones Fe &

4/15/2013



Movement	EBT	EBR	WBL	WBT	NWL	NWR
Lane Configurations	↶			↶↶		↶
Volume (veh/h)	1051	10	0	1384	0	35
Sign Control	Free			Free	Stop	
Grade	0%			0%	0%	
Peak Hour Factor	0.92	0.92	0.92	0.92	0.92	0.92
Hourly flow rate (vph)	1142	11	0	1504	0	38
Pedestrians						
Lane Width (ft)						
Walking Speed (ft/s)						
Percent Blockage						
Right turn flare (veh)						
Median type	TWLTL		None			
Median storage (veh)	2					
Upstream signal (ft)	252					
pX, platoon unblocked			0.63		0.63	0.63
vC, conflicting volume			1153		1900	1148
vC1, stage 1 conf vol					1148	
vC2, stage 2 conf vol					752	
vCu, unblocked vol			949		2136	940
tC, single (s)			4.1		6.8	6.9
tC, 2 stage (s)					5.8	
tF (s)			2.2		3.5	3.3
p0 queue free %			100		100	77
cM capacity (veh/h)			453		185	167

Direction, Lane #	EB 1	WB 1	WB 2	NW 1
Volume Total	1153	752	752	38
Volume Left	0	0	0	0
Volume Right	11	0	0	38
cSH	1700	1700	1700	167
Volume to Capacity	0.68	0.44	0.44	0.23
Queue Length 95th (ft)	0	0	0	21
Control Delay (s)	0.0	0.0	0.0	32.9
Lane LOS				D
Approach Delay (s)	0.0	0.0		32.9
Approach LOS				D

Intersection Summary			
Average Delay		0.5	
Intersection Capacity Utilization		65.9%	ICU Level of Service C
Analysis Period (min)		15	

HCM Signalized Intersection Capacity Analysis

3: SW Boones Ferry Rd & SW Martinazzi Ave

27/03/2013



Movement	EBT	EBR	WBL	WBT	NBL	NBR
Lane Configurations	↑	↑	↑	↑	↑	↑
Volume (vph)	417	145	318	429	201	353
Ideal Flow (vphpl)	1900	1900	1900	1900	1900	1900
Total Lost time (s)	4.5	4.5	4.5	4.5	4.5	4.5
Lane Util. Factor	1.00	1.00	1.00	1.00	1.00	1.00
Frbp, ped/bikes	1.00	1.00	1.00	1.00	1.00	0.99
Flpb, ped/bikes	1.00	1.00	1.00	1.00	1.00	1.00
Frt	1.00	0.85	1.00	1.00	1.00	0.85
Flt Protected	1.00	1.00	0.95	1.00	0.95	1.00
Satd. Flow (prot)	1863	1599	1787	1845	1770	1581
Flt Permitted	1.00	1.00	0.95	1.00	0.95	1.00
Satd. Flow (perm)	1863	1599	1787	1845	1770	1581
Peak-hour factor, PHF	0.95	0.95	0.95	0.95	0.95	0.95
Adj. Flow (vph)	439	153	335	452	212	372
RTOR Reduction (vph)	0	105	0	0	0	96
Lane Group Flow (vph)	439	48	335	452	212	276
Confl. Peds. (#/hr)		11	11		1	3
Confl. Bikes (#/hr)	4		2	10	1	
Heavy Vehicles (%)	2%	1%	1%	3%	2%	1%
Turn Type		Prot	Prot		pm+ov	
Protected Phases	2	2	1	6	8	1
Permitted Phases					8	8
Actuated Green, G (s)	20.4	20.4	17.3	42.7	14.1	31.4
Effective Green, g (s)	20.9	20.9	17.8	43.2	14.6	32.4
Actuated g/C Ratio	0.31	0.31	0.27	0.65	0.22	0.49
Clearance Time (s)	5.0	5.0	5.0	5.0	5.0	5.0
Vehicle Extension (s)	3.0	3.0	3.0	3.0	3.0	3.0
Lane Grp Cap (vph)	583	500	476	1193	387	873
v/s Ratio Prot	c0.24	0.03	c0.19	0.25	c0.12	0.08
v/s Ratio Perm						0.09
v/c Ratio	0.75	0.10	0.70	0.38	0.55	0.32
Uniform Delay, d1	20.6	16.3	22.1	5.5	23.2	10.5
Progression Factor	1.00	1.00	1.00	1.00	1.00	1.00
Incremental Delay, d2	5.5	0.1	4.7	0.2	1.6	0.2
Delay (s)	26.1	16.3	26.8	5.7	24.8	10.7
Level of Service	C	B	C	A	C	B
Approach Delay (s)	23.6			14.7	15.8	
Approach LOS	C			B	B	

Intersection Summary

HCM Average Control Delay	17.7	HCM Level of Service	B
HCM Volume to Capacity ratio	0.68		
Actuated Cycle Length (s)	66.8	Sum of lost time (s)	13.5
Intersection Capacity Utilization	62.6%	ICU Level of Service	B
Analysis Period (min)	15		

c Critical Lane Group

HCM Unsignalized Intersection Capacity Analysis

4: SW Martinazzi Ave &

27/03/2013



Movement	WBL	WBR	NBT	NBR	SBL	SBT
Lane Configurations						
Volume (veh/h)	62	157	396	77	202	257
Sign Control	Stop		Free			Free
Grade	0%		0%			0%
Peak Hour Factor	0.92	0.92	0.92	0.92	0.92	0.92
Hourly flow rate (vph)	67	171	430	84	220	279
Pedestrians						
Lane Width (ft)						
Walking Speed (ft/s)						
Percent Blockage						
Right turn flare (veh)						
Median type			None		TWLTL	
Median storage veh					2	
Upstream signal (ft)			467		315	
pX, platoon unblocked	1.00	1.00			1.00	
vC, conflicting volume	1191	472			514	
vC1, stage 1 conf vol	472					
vC2, stage 2 conf vol	718					
vCu, unblocked vol	1191	472			514	
tC, single (s)	6.4	6.2			4.1	
tC, 2 stage (s)	5.4					
tF (s)	3.5	3.3			2.2	
p0 queue free %	80	71			79	
cM capacity (veh/h)	345	592			1051	

Direction, Lane #	WB 1	WB 2	NB 1	SB 1	SB 2
Volume Total	67	171	514	220	279
Volume Left	67	0	0	220	0
Volume Right	0	171	84	0	0
cSH	345	592	1700	1051	1700
Volume to Capacity	0.20	0.29	0.30	0.21	0.16
Queue Length 95th (ft)	19	31	0	20	0
Control Delay (s)	17.9	13.5	0.0	9.3	0.0
Lane LOS	C	B		A	
Approach Delay (s)	14.8		0.0	4.1	
Approach LOS	B				

Intersection Summary					
Average Delay			4.4		
Intersection Capacity Utilization			50.1%	ICU Level of Service	A
Analysis Period (min)			15		

HCM Unsignalized Intersection Capacity Analysis

5: Seneca St & Martinazzi Ave

27/03/2013



Movement	EBL	EBR	NBL	NBT	SBT	SBR
Lane Configurations						
Volume (veh/h)	37	45	81	437	275	44
Sign Control	Stop			Free	Free	
Grade	0%			0%	0%	
Peak Hour Factor	0.91	0.91	0.91	0.91	0.91	0.91
Hourly flow rate (vph)	41	49	89	480	302	48
Pedestrians	1			4	10	
Lane Width (ft)	12.0			12.0	12.0	
Walking Speed (ft/s)	4.0			4.0	4.0	
Percent Blockage	0			0	1	
Right turn flare (veh)						
Median type				None	None	
Median storage (veh)						
Upstream signal (ft)				307	475	
pX, platoon unblocked	0.97					
vC, conflicting volume	996	331	352			
vC1, stage 1 conf vol						
vC2, stage 2 conf vol						
vCu, unblocked vol	979	331	352			
tC, single (s)	6.4	6.2	4.1			
tC, 2 stage (s)						
tF (s)	3.5	3.3	2.2			
p0 queue free %	84	93	93			
cM capacity (veh/h)	249	712	1217			

Direction, Lane #	EB 1	NB 1	NB 2	SB 1
Volume Total	90	89	480	351
Volume Left	41	89	0	0
Volume Right	49	0	0	48
cSH	387	1217	1700	1700
Volume to Capacity	0.23	0.07	0.28	0.21
Queue Length 95th (ft)	23	6	0	0
Control Delay (s)	17.1	8.2	0.0	0.0
Lane LOS	C	A		
Approach Delay (s)	17.1	1.3		0.0
Approach LOS	C			

Intersection Summary			
Average Delay	2.2		
Intersection Capacity Utilization	37.7%	ICU Level of Service	A
Analysis Period (min)	15		

HCM Unsignalized Intersection Capacity Analysis

6: Martinazzi Ave &

27/03/2013



Movement	WBL	WBR	NBT	NBR	SBL	SBT
Lane Configurations						
Volume (veh/h)	5	25	494	9	3	318
Sign Control	Stop		Free			Free
Grade	0%		0%			0%
Peak Hour Factor	0.92	0.92	0.92	0.92	0.92	0.92
Hourly flow rate (vph)	5	27	537	10	3	346
Pedestrians						
Lane Width (ft)						
Walking Speed (ft/s)						
Percent Blockage						
Right turn flare (veh)						
Median type			None			None
Median storage (veh)						
Upstream signal (ft)			239			543
pX, platoon unblocked						
vC, conflicting volume	721	273			547	
vC1, stage 1 conf vol						
vC2, stage 2 conf vol						
vCu, unblocked vol	721	273			547	
tC, single (s)	6.8	6.9			4.1	
tC, 2 stage (s)						
tF (s)	3.5	3.3			2.2	
p0 queue free %	98	96			100	
cM capacity (veh/h)	361	724			1019	

Direction, Lane #	WB 1	NB 1	NB 2	SB 1	SB 2
Volume Total	33	358	189	118	230
Volume Left	5	0	0	3	0
Volume Right	27	0	10	0	0
cSH	620	1700	1700	1019	1700
Volume to Capacity	0.05	0.21	0.11	0.00	0.14
Queue Length 95th (ft)	4	0	0	0	0
Control Delay (s)	11.1	0.0	0.0	0.3	0.0
Lane LOS	B			A	
Approach Delay (s)	11.1	0.0		0.1	
Approach LOS	B				

Intersection Summary					
Average Delay			0.4		
Intersection Capacity Utilization			23.9%	ICU Level of Service	A
Analysis Period (min)			15		

HCM Unsignalized Intersection Capacity Analysis

7: Martinazzi Ave &

27/03/2013



Movement	WBL	WBR	NBT	NBR	SBL	SBT
Lane Configurations		↗	↑			↘↘
Volume (veh/h)	0	10	493	0	0	322
Sign Control	Stop		Free			Free
Grade	0%		0%			0%
Peak Hour Factor	0.92	0.92	0.92	0.92	0.92	0.92
Hourly flow rate (vph)	0	11	536	0	0	350
Pedestrians						
Lane Width (ft)						
Walking Speed (ft/s)						
Percent Blockage						
Right turn flare (veh)						
Median type			None			None
Median storage (veh)						
Upstream signal (ft)			111			671
pX, platoon unblocked	0.89	0.89			0.89	
vC, conflicting volume	711	536			536	
vC1, stage 1 conf vol						
vC2, stage 2 conf vol						
vCu, unblocked vol	610	412			412	
tC, single (s)	6.8	6.9			4.1	
tC, 2 stage (s)						
tF (s)	3.5	3.3			2.2	
p0 queue free %	100	98			100	
cM capacity (veh/h)	378	522			1013	





















Direction, Lane #	WB 1	NB 1	SB 1	SB 2
Volume Total	11	536	175	175
Volume Left	0	0	0	0
Volume Right	11	0	0	0
cSH	522	1700	1700	1700
Volume to Capacity	0.02	0.32	0.10	0.10
Queue Length 95th (ft)	2	0	0	0
Control Delay (s)	12.0	0.0	0.0	0.0
Lane LOS	B			
Approach Delay (s)	12.0	0.0	0.0	
Approach LOS	B			

Intersection Summary			
Average Delay		0.1	
Intersection Capacity Utilization		35.9%	ICU Level of Service A
Analysis Period (min)		15	

HCM Signalized Intersection Capacity Analysis

8: Nyberg St & Martinazzi Ave

4/17/2013

												
Movement	EBL	EBT	EBR	WBL	WBT	WBR	NBL	NBT	NBR	SBL	SBT	SBR
Lane Configurations												
Volume (vph)	16	1	63	260	37	237	23	240	36	0	314	8
Ideal Flow (vphpl)	1900	1900	1900	1900	1900	1900	1900	1900	1900	1900	1900	1900
Total Lost time (s)	5.5	5.5		5.5	5.5	5.5	5.5	5.5			5.5	
Lane Util. Factor	1.00	1.00		0.95	0.95	1.00	1.00	1.00			0.95	
Frbp, ped/bikes	1.00	1.00		1.00	1.00	0.97	1.00	0.99			1.00	
Flpb, ped/bikes	1.00	1.00		1.00	1.00	1.00	1.00	1.00			1.00	
Frt	1.00	0.85		1.00	1.00	0.85	1.00	0.98			1.00	
Flt Protected	0.95	1.00		0.95	0.96	1.00	0.95	1.00			1.00	
Satd. Flow (prot)	1805	1603		1698	1727	1543	1683	1837			3559	
Flt Permitted	0.95	1.00		0.95	0.96	1.00	0.54	1.00			1.00	
Satd. Flow (perm)	1805	1603		1698	1727	1543	957	1837			3559	
Peak-hour factor, PHF	0.91	0.91	0.91	0.91	0.91	0.91	0.91	0.91	0.91	0.91	0.91	0.91
Adj. Flow (vph)	18	1	69	286	41	260	25	264	40	0	345	9
RTOR Reduction (vph)	0	63	0	0	0	202	0	8	0	0	3	0
Lane Group Flow (vph)	18	7	0	163	164	58	25	296	0	0	351	0
Confl. Peds. (#/hr)	2					2	3		16	16		3
Confl. Bikes (#/hr)						2						3
Heavy Vehicles (%)	0%	0%	1%	1%	0%	2%	7%	1%	0%	0%	1%	0%
Turn Type	Split			Split			Perm	Perm				
Protected Phases	8	8		4	4			6			2	
Permitted Phases						4	6					
Actuated Green, G (s)	3.1	3.1		9.1	9.1	9.1	12.5	12.5			12.5	
Effective Green, g (s)	3.6	3.6		9.6	9.6	9.6	13.0	13.0			13.0	
Actuated g/C Ratio	0.08	0.08		0.22	0.22	0.22	0.30	0.30			0.30	
Clearance Time (s)	6.0	6.0		6.0	6.0	6.0	6.0	6.0			6.0	
Vehicle Extension (s)	2.5	2.5		2.5	2.5	2.5	5.0	5.0			5.0	
Lane Grp Cap (vph)	152	135		382	388	347	291	559			1084	
v/s Ratio Prot	c0.01	0.00		c0.10	0.09			c0.16			0.10	
v/s Ratio Perm						0.04	0.03					
v/c Ratio	0.12	0.05		0.43	0.42	0.17	0.09	0.53			0.32	
Uniform Delay, d1	18.1	18.0		14.2	14.2	13.3	10.6	12.3			11.5	
Progression Factor	1.00	1.00		1.00	1.00	1.00	1.00	1.00			1.00	
Incremental Delay, d2	0.3	0.1		0.6	0.5	0.2	0.3	1.8			0.4	
Delay (s)	18.3	18.1		14.8	14.7	13.5	10.9	14.1			11.8	
Level of Service	B	B		B	B	B	B	B			B	
Approach Delay (s)		18.1			14.2			13.8			11.8	
Approach LOS		B			B			B			B	
Intersection Summary												
HCM Average Control Delay			13.7								HCM Level of Service	B
HCM Volume to Capacity ratio			0.44									
Actuated Cycle Length (s)			42.7								Sum of lost time (s)	16.5
Intersection Capacity Utilization			48.7%								ICU Level of Service	A
Analysis Period (min)			15									

c Critical Lane Group

HCM Unsignalized Intersection Capacity Analysis

9: Nyberg St & Site Entrance 3



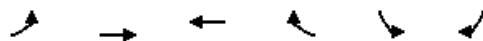

























4/17/2013



Movement	EBL	EBT	WBT	WBR	SBL	SBR
Lane Configurations	↰		↱↰			↱
Volume (veh/h)	37	0	466	60	0	67
Sign Control		Free	Free		Stop	
Grade		0%	0%		0%	
Peak Hour Factor	0.88	0.88	0.88	0.88	0.88	0.88
Hourly flow rate (vph)	42	0	530	68	0	76
Pedestrians					4	
Lane Width (ft)					12.0	
Walking Speed (ft/s)					4.0	
Percent Blockage					0	
Right turn flare (veh)						
Median type		None	None			
Median storage (veh)						
Upstream signal (ft)		232				
pX, platoon unblocked						
vC, conflicting volume	602				652	303
vC1, stage 1 conf vol						
vC2, stage 2 conf vol						
vCu, unblocked vol	602				652	303
tC, single (s)	4.1				6.8	6.9
tC, 2 stage (s)						
tF (s)	2.2				3.5	3.3
p0 queue free %	96				100	89
cM capacity (veh/h)	982				387	697
Direction, Lane #	EB 1	WB 1	WB 2	SB 1		
Volume Total	42	353	245	76		
Volume Left	42	0	0	0		
Volume Right	0	0	68	76		
cSH	982	1700	1700	697		
Volume to Capacity	0.04	0.21	0.14	0.11		
Queue Length 95th (ft)	3	0	0	10		
Control Delay (s)	8.8	0.0	0.0	10.8		
Lane LOS	A			B		
Approach Delay (s)	8.8	0.0		10.8		
Approach LOS				B		
Intersection Summary						
Average Delay			1.7			
Intersection Capacity Utilization			25.7%		ICU Level of Service	A
Analysis Period (min)			15			

HCM Signalized Intersection Capacity Analysis
 10: Tualatin Sherwood Rd & Site Entrance 4

4/17/2013

												
Movement	EBL	EBT	EBR	WBL	WBT	WBR	NBL	NBT	NBR	SBL	SBT	SBR
Lane Configurations		  		 	  					 		
Volume (vph)	180	1335	59	257	1458	361	57	25	248	373	40	190
Ideal Flow (vphpl)	1900	1900	1900	1900	1900	1900	1900	1900	1900	1900	1900	1900
Total Lost time (s)	4.5	6.0		4.5	6.0	6.0		5.0	4.5	5.0	5.0	
Lane Util. Factor	1.00	*0.75		0.97	0.91	1.00		1.00	1.00	0.97	1.00	
Frbp, ped/bikes	1.00	1.00		1.00	1.00	0.97		1.00	1.00	1.00	0.98	
Flpb, ped/bikes	1.00	1.00		1.00	1.00	1.00		1.00	1.00	1.00	1.00	
Frt	1.00	0.99		1.00	1.00	0.85		1.00	0.85	1.00	0.88	
Flt Protected	0.95	1.00		0.95	1.00	1.00		0.97	1.00	0.95	1.00	
Satd. Flow (prot)	1805	4091		3502	4988	1565		1799	1599	3467	1634	
Flt Permitted	0.95	1.00		0.95	1.00	1.00		0.97	1.00	0.95	1.00	
Satd. Flow (perm)	1805	4091		3502	4988	1565		1799	1599	3467	1634	
Peak-hour factor, PHF	0.98	0.98	0.98	0.98	0.98	0.98	0.98	0.98	0.98	0.98	0.98	0.98
Adj. Flow (vph)	184	1362	60	262	1488	368	58	26	253	381	41	194
RTOR Reduction (vph)	0	3	0	0	0	201	0	0	0	0	164	0
Lane Group Flow (vph)	184	1419	0	262	1488	167	0	84	253	381	71	0
Confl. Peds. (#/hr)						4						9
Confl. Bikes (#/hr)					1			1		1		
Heavy Vehicles (%)	0%	4%	0%	0%	4%	0%	3%	0%	1%	1%	0%	0%
Turn Type	Prot			Prot		Perm	Split		pt+ov	Split		
Protected Phases	5	2		1	6		8	8	18	4	4	
Permitted Phases						6						
Actuated Green, G (s)	14.8	49.6		17.0	51.8	51.8		8.5	25.5	17.4	17.4	
Effective Green, g (s)	15.3	50.1		17.5	52.3	52.3		9.0	26.5	17.9	17.9	
Actuated g/C Ratio	0.13	0.44		0.15	0.45	0.45		0.08	0.23	0.16	0.16	
Clearance Time (s)	5.0	6.5		5.0	6.5	6.5		5.5		5.5	5.5	
Vehicle Extension (s)	2.5	4.0		2.5	4.0	4.0		2.5		2.5	2.5	
Lane Grp Cap (vph)	240	1782		533	2268	712		141	368	540	254	
v/s Ratio Prot	0.10	c0.35		0.07	c0.30			0.05	c0.16	c0.11	0.04	
v/s Ratio Perm						0.11						
v/c Ratio	0.77	0.80		0.49	0.66	0.24		0.60	0.69	0.71	0.28	
Uniform Delay, d1	48.1	28.0		44.7	24.4	19.1		51.2	40.5	46.1	42.9	
Progression Factor	0.90	1.35		0.96	0.90	1.07		1.00	1.00	1.00	1.00	
Incremental Delay, d2	10.1	2.9		0.3	1.0	0.5		5.5	4.8	3.9	0.4	
Delay (s)	53.6	40.7		43.3	23.0	20.9		56.8	45.3	49.9	43.3	
Level of Service	D	D		D	C	C		E	D	D	D	
Approach Delay (s)		42.2			25.2			48.2			47.4	
Approach LOS		D			C			D			D	













Intersection Summary			
HCM Average Control Delay	35.6	HCM Level of Service	D
HCM Volume to Capacity ratio	0.71		
Actuated Cycle Length (s)	115.0	Sum of lost time (s)	15.5
Intersection Capacity Utilization	77.3%	ICU Level of Service	D
Analysis Period (min)	15		

c Critical Lane Group

HCM Signalized Intersection Capacity Analysis

12: Tualatin Sherwood Rd & I-5 SB Ramps













4/17/2013

													
Movement	EBL	EBT	EBR	WBL	WBT	WBR	NBL	NBT	NBR	SBL	SBT	SBR	
Lane Configurations		↑↑↑	↑	↑	↑↑					↑	↑	↑↑	
Volume (vph)	0	1484	480	193	1150	0	0	0	0	620	3	965	
Ideal Flow (vphpl)	1900	1900	1900	1900	1900	1900	1900	1900	1900	1900	1900	1900	
Total Lost time (s)		5.5	5.5	5.5	5.5					5.5	5.5	5.5	
Lane Util. Factor		*0.75	1.00	1.00	0.95					0.95	0.95	0.88	
Frbp, ped/bikes		1.00	1.00	1.00	1.00					1.00	1.00	1.00	
Flpb, ped/bikes		1.00	1.00	1.00	1.00					1.00	1.00	1.00	
Frt		1.00	0.85	1.00	1.00					1.00	1.00	0.85	
Flt Protected		1.00	1.00	0.95	1.00					0.95	0.95	1.00	
Satd. Flow (prot)		4150	1568	1787	3471					1681	1683	2760	
Flt Permitted		1.00	1.00	0.95	1.00					0.95	0.95	1.00	
Satd. Flow (perm)		4150	1568	1787	3471					1681	1683	2760	
Peak-hour factor, PHF	0.99	0.99	0.99	0.99	0.99	0.99	0.99	0.99	0.99	0.99	0.99	0.99	
Adj. Flow (vph)	0	1499	485	195	1162	0	0	0	0	626	3	975	
RTOR Reduction (vph)	0	0	242	0	0	0	0	0	0	0	0	40	
Lane Group Flow (vph)	0	1499	243	195	1162	0	0	0	0	313	316	935	
Confl. Bikes (#/hr)		1			2								
Heavy Vehicles (%)	0%	3%	3%	1%	4%	0%	0%	0%	0%	2%	20%	3%	
Turn Type			Perm	Prot						Split		custom	
Protected Phases		2		1	6					4	4	4.5	
Permitted Phases			2										
Actuated Green, G (s)		49.4	49.4	17.0	55.4					30.6	30.6	47.6	
Effective Green, g (s)		49.9	49.9	17.5	55.9					31.1	31.1	44.6	
Actuated g/C Ratio		0.43	0.43	0.15	0.49					0.27	0.27	0.39	
Clearance Time (s)		6.0	6.0	6.0	6.0					6.0	6.0		
Vehicle Extension (s)		6.1	6.1	2.3	6.1					2.3	2.3		
Lane Grp Cap (vph)		1801	680	272	1687					455	455	1070	
v/s Ratio Prot		c0.36		c0.11	0.33					0.19	0.19	c0.34	
v/s Ratio Perm			0.16										
v/c Ratio		0.83	0.36	0.72	0.69					0.69	0.69	0.87	
Uniform Delay, d1		28.8	21.8	46.4	22.8					37.6	37.7	32.6	
Progression Factor		0.60	0.38	0.88	0.62					1.00	1.00	1.00	
Incremental Delay, d2		3.3	1.0	7.3	2.2					3.7	4.0	7.9	
Delay (s)		20.5	9.4	48.1	16.3					41.3	41.7	40.5	
Level of Service		C	A	D	B					D	D	D	
Approach Delay (s)		17.8			20.9			0.0			40.9		
Approach LOS		B			C			A			D		
Intersection Summary													
HCM Average Control Delay			26.1			HCM Level of Service				C			
HCM Volume to Capacity ratio			0.89										
Actuated Cycle Length (s)			115.0			Sum of lost time (s)				22.0			
Intersection Capacity Utilization			74.7%			ICU Level of Service				D			
Analysis Period (min)			15										
c Critical Lane Group													

HCM Signalized Intersection Capacity Analysis

13: Tualatin Sherwood Rd & I-5 NB Ramps





















4/17/2013

												
Movement	EBL	EBT	EBR	WBL	WBT	WBR	NBL	NBT	NBR	SBL	SBT	SBR
Lane Configurations		↑↑	↑↑		↑↑	↑	↑	↑	↑			
Volume (vph)	0	1110	998	0	668	666	672	0	219	0	0	0
Ideal Flow (vphpl)	1900	1900	1900	1900	1900	1900	1900	1900	1900	1900	1900	1900
Total Lost time (s)		5.5	5.5		6.0	6.0	5.5	5.5	5.5			
Lane Util. Factor		0.95	0.88		0.95	1.00	0.95	0.95	1.00			
Frbp, ped/bikes		1.00	0.98		1.00	1.00	1.00	1.00	0.98			
Flpb, ped/bikes		1.00	1.00		1.00	1.00	1.00	1.00	1.00			
Frt		1.00	0.85		1.00	0.85	1.00	1.00	0.85			
Flt Protected		1.00	1.00		1.00	1.00	0.95	0.95	1.00			
Satd. Flow (prot)		3574	2694		3574	1583	1618	1618	1559			
Flt Permitted		1.00	1.00		1.00	1.00	0.95	0.95	1.00			
Satd. Flow (perm)		3574	2694		3574	1583	1618	1618	1559			
Peak-hour factor, PHF	0.95	0.95	0.95	0.95	0.95	0.95	0.95	0.95	0.95	0.95	0.95	0.95
Adj. Flow (vph)	0	1168	1051	0	703	701	707	0	231	0	0	0
RTOR Reduction (vph)	0	0	388	0	0	262	0	0	28	0	0	0
Lane Group Flow (vph)	0	1168	663	0	703	439	353	354	203	0	0	0
Confl. Peds. (#/hr)			1	1			1		2	2		1
Confl. Bikes (#/hr)		1			5					1		
Heavy Vehicles (%)	0%	1%	3%	0%	1%	2%	6%	20%	2%	0%	0%	0%
Turn Type			Perm			Perm	Split		Perm			
Protected Phases		2			6		8	8				
Permitted Phases			2			6			8			
Actuated Green, G (s)		72.0	72.0		71.5	71.5	31.0	31.0	31.0			
Effective Green, g (s)		72.5	72.5		72.0	72.0	31.5	31.5	31.5			
Actuated g/C Ratio		0.63	0.63		0.63	0.63	0.27	0.27	0.27			
Clearance Time (s)		6.0	6.0		6.5	6.5	6.0	6.0	6.0			
Vehicle Extension (s)		6.1	6.1		4.2	4.2	2.3	2.3	2.3			
Lane Grp Cap (vph)		2253	1698		2238	991	443	443	427			
v/s Ratio Prot		c0.33			0.20		0.22	c0.22				
v/s Ratio Perm			0.25			0.28			0.13			
v/c Ratio		0.52	0.39		0.31	0.44	0.80	0.80	0.47			
Uniform Delay, d1		11.7	10.4		10.0	11.1	38.8	38.8	34.8			
Progression Factor		1.39	3.10		1.00	1.00	1.00	1.00	1.00			
Incremental Delay, d2		0.6	0.4		0.4	1.4	9.2	9.3	0.5			
Delay (s)		16.7	32.8		10.4	12.6	48.0	48.1	35.3			
Level of Service		B	C		B	B	D	D	D			
Approach Delay (s)		24.3			11.5			44.9			0.0	
Approach LOS		C			B			D			A	
Intersection Summary												
HCM Average Control Delay			24.6									C
HCM Volume to Capacity ratio			0.60									
Actuated Cycle Length (s)			115.0									11.0
Intersection Capacity Utilization			69.4%									C
Analysis Period (min)			15									

c Critical Lane Group

HCM Signalized Intersection Capacity Analysis
 14: Tualatin Sherwood Rd & Nyberg Woods

4/17/2013

























													
Movement	EBL	EBT	EBR	WBL	WBT	WBR	NBL	NBT	NBR	SBL	SBT	SBR	
Lane Configurations													
Volume (vph)	524	593	57	15	732	101	103	11	12	101	11	322	
Ideal Flow (vphpl)	1900	1900	1900	1900	1900	1900	1900	1900	1900	1900	1900	1900	
Total Lost time (s)	5.5	5.5		5.5	5.5			5.5	5.5		5.5	5.5	
Lane Util. Factor	0.97	0.95		1.00	0.95			1.00	1.00		1.00	1.00	
Frbp, ped/bikes	1.00	1.00		1.00	1.00			1.00	0.99		1.00	0.99	
Flpb, ped/bikes	1.00	1.00		1.00	1.00			1.00	1.00		1.00	1.00	
Frt	1.00	0.99		1.00	0.98			1.00	0.85		1.00	0.85	
Flt Protected	0.95	1.00		0.95	1.00			0.96	1.00		0.96	1.00	
Satd. Flow (prot)	3502	3486		1805	3505			1768	1593		1799	1594	
Flt Permitted	0.95	1.00		0.95	1.00			0.66	1.00		0.66	1.00	
Satd. Flow (perm)	3502	3486		1805	3505			1229	1593		1248	1594	
Peak-hour factor, PHF	0.96	0.96	0.96	0.96	0.96	0.96	0.96	0.96	0.96	0.96	0.96	0.96	
Adj. Flow (vph)	546	618	59	16	762	105	107	11	12	105	11	335	
RTOR Reduction (vph)	0	5	0	0	9	0	0	0	10	0	0	279	
Lane Group Flow (vph)	546	672	0	16	858	0	0	118	2	0	116	56	
Confl. Peds. (#/hr)	8		2	2		8	1		2	2		1	
Confl. Bikes (#/hr)		1			3								
Heavy Vehicles (%)	0%	2%	2%	0%	1%	0%	3%	0%	0%	1%	0%	0%	
Turn Type	Prot			Prot			Perm		Perm	Perm		Perm	
Protected Phases	5	2		1	6			8				4	
Permitted Phases							8		8	4		4	
Actuated Green, G (s)	14.5	38.4		0.8	24.7			10.9	10.9			10.9	
Effective Green, g (s)	15.0	38.9		1.3	25.2			11.4	11.4			11.4	
Actuated g/C Ratio	0.22	0.57		0.02	0.37			0.17	0.17			0.17	
Clearance Time (s)	6.0	6.0		6.0	6.0			6.0	6.0			6.0	
Vehicle Extension (s)	2.3	2.5		2.4	2.5			2.4	2.4			2.3	
Lane Grp Cap (vph)	771	1991		34	1297			206	267			209	
v/s Ratio Prot	c0.16	0.19		0.01	c0.24								
v/s Ratio Perm								c0.10	0.00			0.09	
v/c Ratio	0.71	0.34		0.47	0.66			0.57	0.01			0.56	
Uniform Delay, d1	24.5	7.8		33.1	17.9			26.1	23.6			26.0	
Progression Factor	1.00	1.00		1.00	1.00			1.00	1.00			1.00	
Incremental Delay, d2	2.6	0.1		6.6	1.2			3.0	0.0			2.3	
Delay (s)	27.2	7.8		39.7	19.0			29.1	23.6			28.3	
Level of Service	C	A		D	B			C	C			C	
Approach Delay (s)		16.5			19.4			28.6				25.6	
Approach LOS		B			B			C				C	

Intersection Summary		
HCM Average Control Delay	19.6	HCM Level of Service B
HCM Volume to Capacity ratio	0.66	
Actuated Cycle Length (s)	68.1	Sum of lost time (s) 16.5
Intersection Capacity Utilization	65.6%	ICU Level of Service C
Analysis Period (min)	15	

c Critical Lane Group

HCM Signalized Intersection Capacity Analysis
 17: Tualatin Sherwood Rd & Martinazzi Ave

4/17/2013

												
Movement	EBL	EBT	EBR	WBL	WBT	WBR	NBL	NBT	NBR	SBL	SBT	SBR
Lane Configurations		 			 						 	
Volume (vph)	75	1194	141	0	1163	0	100	225	252	129	415	93
Ideal Flow (vphpl)	1900	1900	1900	1900	1900	1900	1900	1900	1900	1900	1900	1900
Total Lost time (s)	4.5	5.5			5.5		4.5	5.5	5.5	4.5	5.5	
Lane Util. Factor	1.00	0.95			0.95		1.00	1.00	1.00	1.00	0.95	
Frbp, ped/bikes	1.00	1.00			1.00		1.00	1.00	0.96	1.00	1.00	
Flpb, ped/bikes	1.00	1.00			1.00		1.00	1.00	1.00	1.00	1.00	
Frt	1.00	0.98			1.00		1.00	1.00	0.85	1.00	0.97	
Flt Protected	0.95	1.00			1.00		0.95	1.00	1.00	0.95	1.00	
Satd. Flow (prot)	1719	3430			3438		1770	1863	1537	1787	3466	
Flt Permitted	0.95	1.00			1.00		0.95	1.00	1.00	0.95	1.00	
Satd. Flow (perm)	1719	3430			3438		1770	1863	1537	1787	3466	
Peak-hour factor, PHF	0.94	0.94	0.94	0.94	0.94	0.94	0.94	0.94	0.94	0.94	0.94	0.94
Adj. Flow (vph)	80	1270	150	0	1237	0	106	239	268	137	441	99
RTOR Reduction (vph)	0	6	0	0	0	0	0	0	104	0	19	0
Lane Group Flow (vph)	80	1414	0	0	1237	0	106	239	164	137	521	0
Confl. Peds. (#/hr)							6		23			3
Heavy Vehicles (%)	5%	4%	0%	0%	5%	0%	2%	2%	1%	1%	1%	1%
Turn Type	Prot							Prot		Perm	Prot	
Protected Phases	5	2			6		3	8		7	4	
Permitted Phases									8			
Actuated Green, G (s)	8.6	66.5			52.9		10.6	17.9	17.9	13.6	20.9	
Effective Green, g (s)	9.1	67.0			53.4		11.1	18.4	18.4	14.1	21.4	
Actuated g/C Ratio	0.08	0.58			0.46		0.10	0.16	0.16	0.12	0.19	
Clearance Time (s)	5.0	6.0			6.0		5.0	6.0	6.0	5.0	6.0	
Vehicle Extension (s)	2.0	3.5			3.5		3.0	2.0	2.0	3.0	2.0	
Lane Grp Cap (vph)	136	1998			1596		171	298	246	219	645	
v/s Ratio Prot	0.05	c0.41			c0.36		0.06	c0.13		0.08	c0.15	
v/s Ratio Perm									0.11			
v/c Ratio	0.59	0.71			0.78		0.62	0.80	0.67	0.63	0.81	
Uniform Delay, d1	51.1	17.0			25.8		49.9	46.5	45.4	47.9	44.8	
Progression Factor	1.00	1.00			0.56		1.00	1.00	1.00	1.00	1.00	
Incremental Delay, d2	4.1	2.1			3.0		6.5	13.6	5.2	5.5	7.0	
Delay (s)	55.3	19.2			17.5		56.5	60.1	50.6	53.4	51.8	
Level of Service	E	B			B		E	E	D	D	D	
Approach Delay (s)		21.1			17.5			55.3			52.1	
Approach LOS		C			B			E			D	
Intersection Summary												
HCM Average Control Delay			30.4				HCM Level of Service			C		
HCM Volume to Capacity ratio			0.83									
Actuated Cycle Length (s)			115.0				Sum of lost time (s)		22.0			
Intersection Capacity Utilization			81.1%				ICU Level of Service		D			
Analysis Period (min)			15									
c Critical Lane Group												

SIGNALIZED QUEUE ANALYSIS

Project Name: Nyberg Rivers
Project Number: 12116
Analyst: CLB
Date: 4/16/2013
Filename: C:\Users\mvandehey\Documents\[Signalized Queue FM Driveway2.xls]SIGQUEE



KITTELSON & ASSOCIATES, INC.
 610 SW Alder, Suite 700
 Portland, Oregon 97205
 (503) 228-5230
 Fax: (503) 273-8169

Intersection: Fred Meyer Access/Nyberg Road
Conditions (yr, alt., etc.): Weekday

GENERAL INPUT PARAMETERS:

Cycle Length:	125 sec
Confidence Level (C.L.):	95%
Storage length/vehicle:	25 feet

	APPROACH/MOVEMENT							
	#1	#2	#3	#4	#5	#6	#7	#8
	EB LT EX	EB LT BK	EB LT WS	EX SB LT	BK SB LT	WS SB LT		
INPUT PARAMETERS:								
Volume (pre-PHF) (vph):	30	30	100	182	182	323		
G/C for movement:	0.05	0.05	0.12	0.18	0.18	0.14		
Number of lanes:	1	1	1	1	1	2	2	2
CALCULATIONS:								
Length of red interval (sec):	118.8	118.8	110.0	102.5	102.5	107.5		
Average total queue (veh):	1.0	1.0	3.1	5.2	5.2	9.6		
Maximum total queue (veh):	3	3	6	9	9	15		
Total queue length (feet):	75	75	150	225	225	375		
Required storage/lane (feet):	75	75	150	225	225	200		
PERMITTED LEFT TURNS:								
Opposing volume (pre-PHF):								
Opposing sat. flow rate:								
CALCULATIONS:								
Opposing flow ratio (Yo):								
Unblocked G/C:								
Effective red interval (sec):								
Average total queue (veh):								
Maximum total queue (veh):								
Total queue length (feet):								
Required storage/lane (feet):								

METHODOLOGY AND FORMULAS USED:

Length of red interval = $(1 - G/C) * \text{Cycle length}$

Average queue/lane = $\text{Volume} * \text{Red Interval} / 3600$

Maximum queue: Random arrival/Constant service

Random arrivals behave according to a Poisson distribution.

There is a probability equal to the confidence level desired (e.g. 95%) that the queue formed during each red interval will be less than or equal to the maximum queue.

(Prob. of arrivals = N) = $(\text{Red Interval})^N * \exp(-N) / N!$ (the Poisson distribution)

(Prob. of arrivals >= N) = $1 - \text{Sum of probabilities for vehicles } 0, 1, \dots, N-1$

Max N: Highest N such that the sum of probabilities > (1 - confidence level)

Queue length = $\text{Maximum queue} * \text{Storage length per vehicle}$

Required storage per lane = $\text{Queue length} / \text{Number of lanes}$, rounded up to the next highest whole vehicle

Opposing flow ratio Yo = $\text{opposing volume } v_o / \text{opposing sat. flow rate } s_{op}$

Unblocked G/C (gu/C) = $(g/C - Y_o) / (1 - Y_o)$

SIGNALIZED QUEUE ANALYSIS

Project Name: Nyberg Rivers
Project Number: 12116
Analyst: CLB
Date: 4/16/2013
Filename:

C:\Users\mrvandehey\AppData\Local\Microsoft\Windows\Temporary Internet Files\Content.IE5\...



KITTELSON & ASSOCIATES, INC.
 610 SW Alder, Suite 700
 Portland, Oregon 97205
 (503) 228-5230
 Fax: (503) 273-8169

Intersection: Fred Meyer Access/Nyberg Road
Conditions (yr, alt., etc.):

GENERAL INPUT PARAMETERS:

Cycle Length:	125 sec
Confidence Level (C.L.):	95%
Storage length/vehicle:	25 feet

	APPROACH/MOVEMENT							
	#1	#2	#3	#4	#5	#6	#7	#8
	NB RT EX PI	NB RT BK	NB RT WS	NB 2RT WS	EX WB LT	WB LT EX	WB LT BK	WB LT WS
INPUT PARAMETERS:								
Volume (pre-PHF) (vph):	236	236	236	236	232	232	232	232
G/C for movement:	0.28	0.28	0.21	0.17	0.10	0.10	0.10	0.13
Number of lanes:	1	1	1	2	2	2	2	2
CALCULATIONS:								
Length of red interval (sec):	90.0	90.0	98.8	103.8	112.5	112.5	112.5	108.8
Average total queue (veh):	5.9	5.9	6.5	6.8	7.3	7.3	7.3	7.0
Maximum total queue (veh):	10	10	11	11	12	12	12	12
Total queue length (feet):	250	250	275	275	300	300	300	300
Required storage/lane (feet):	250	250	275	150	150	150	150	150
PERMITTED LEFT TURNS:								
Opposing volume (pre-PHF):								
Opposing sat. flow rate:								
CALCULATIONS:								
Opposing flow ratio (Yo):								
Unblocked G/C:								
Effective red interval (sec):								
Average total queue (veh):								
Maximum total queue (veh):								
Total queue length (feet):								
Required storage/lane (feet):								

METHODOLOGY AND FORMULAS USED:

Length of red interval = (1 - G/C) * Cycle length

Average queue/lane = Volume * Red Interval / 3600

Maximum queue: Random arrival/Constant service

Random arrivals behave according to a Poisson distribution.

There is a probability equal to the confidence level desired (e.g. 95%)

that the queue formed during each red interval will be less than or equal to the maximum queue.

(Prob. of arrivals = N) = (Red Interval)^N * exp(-N) / N! (the Poisson distribution)

(Prob. of arrivals >= N) = 1 - Sum of probabilities for vehicles 0, 1, ..., N-1

Max N: Highest N such that the sum of probabilities > (1 - confidence level)

Queue length = Maximum queue * Storage length per vehicle

Required storage per lane = Queue length / Number of lanes, rounded up to the next highest whole vehicle

Opposing flow ratio Yo = opposing volume vo / opposing sat. flow rate sop

Unblocked G/C (gu/C) = (g/C - Yo)/(1-Yo)

SIGNALIZED QUEUE ANALYSIS

Project Name: Nyberg Rivers
Project Number: 12116
Analyst: CLB
Date: 4/17/2013
Filename: C:\Users\mvandehey\Documents\Signalized Queue FM Driveway saturday2.xls



KITTELSON & ASSOCIATES, INC.
 610 SW Alder, Suite 700
 Portland, Oregon 97205
 (503) 228-5230
 Fax: (503) 273-8169

Intersection: Fred Meyer Access/Nyberg Road
Conditions (yr, alt., etc.): Saturday

GENERAL INPUT PARAMETERS:

Cycle Length:	115 sec
Confidence Level (C.L.):	95%
Storage length/vehicle:	25 feet

	APPROACH/MOVEMENT						
	#1	#2	#3	#4	#5	#6	#7
	EX EB LT	BK EB LT	WS EB LT		EX SB LT	BK SB LT	WS SB LT
INPUT PARAMETERS:							
Volume (pre-PHF) (vph):	50	50	180		154	154	373
G/C for movement:	0.06	0.07	0.13		0.18	0.18	0.16
Number of lanes:	1	1	1		2	2	2
CALCULATIONS:							
Length of red interval (sec):	108.1	107.0	100.1		94.3	94.3	96.6
Average total queue (veh):	1.5	1.5	5.0		4.0	4.0	10.0
Maximum total queue (veh):	4	4	9		8	8	15
Total queue length (feet):	100	100	225		200	200	375
Required storage/lane (feet):	100	100	225		100	100	200
PERMITTED LEFT TURNS:							
Opposing volume (pre-PHF):							
Opposing sat. flow rate:							
CALCULATIONS:							
Opposing flow ratio (Yo):							
Unblocked G/C:							
Effective red interval (sec):							
Average total queue (veh):							
Maximum total queue (veh):							
Total queue length (feet):							
Required storage/lane (feet):							

METHODOLOGY AND FORMULAS USED:

Length of red interval = $(1 - G/C) * \text{Cycle length}$

Average queue/lane = $\text{Volume} * \text{Red Interval} / 3600$

Maximum queue: Random arrival/Constant service

Random arrivals behave according to a Poisson distribution.

There is a probability equal to the confidence level desired (e.g. 95%) that the queue formed during each red interval will be less than or equal to the maximum queue.

(Prob. of arrivals = N) = $(\text{Red Interval})^N * \exp(-N) / N!$ (the Poisson distribution)

(Prob. of arrivals >= N) = $1 - \text{Sum of probabilities for vehicles } 0, 1, \dots, N-1$

Max N: Highest N such that the sum of probabilities > (1 - confidence level)

Queue length = $\text{Maximum queue} * \text{Storage length per vehicle}$

Required storage per lane = $\text{Queue length} / \text{Number of lanes}$, rounded up to the next highest whole vehicle

Opposing flow ratio Yo = $\text{opposing volume } v_o / \text{opposing sat. flow rate } s_{op}$

Unblocked G/C (gu/C) = $(g/C - Y_o) / (1 - Y_o)$

SIGNALIZED QUEUE ANALYSIS

Project Name: Nyberg Rivers
Project Number: 12116
Analyst: CLB
Date: 4/17/2013
Filename: C:\Users\mvandehey\Documents\Signalized Queue FM Driveway saturday2.xls



KITTELSON & ASSOCIATES, INC.
 610 SW Alder, Suite 700
 Portland, Oregon 97205
 (503) 228-5230
 Fax: (503) 273-8169

Intersection: Fred Meyer Access/Nyberg Road
Conditions (yr, alt., etc.): Saturday

GENERAL INPUT PARAMETERS:

Cycle Length:	115 sec
Confidence Level (C.L.):	95%
Storage length/vehicle:	25 feet

	APPROACH/MOVEMENT						
	#1	#2	#3	#4	#5	#6	#7
	NB RT EX PI	NB RT BK	NB RT WS	EX WB LT	WB LT EX	WB LT BK	
INPUT PARAMETERS:							
Volume (pre-PHF) (vph):	248	248	248		257	257	257
G/C for movement:	0.29	0.29	0.23		0.11	0.11	0.15
Number of lanes:	1	1	1		2	2	2
CALCULATIONS:							
Length of red interval (sec):	81.7	81.7	88.6		102.4	102.4	97.8
Average total queue (veh):	5.6	5.6	6.1		7.3	7.3	7.0
Maximum total queue (veh):	10	10	10		12	12	12
Total queue length (feet):	250	250	250		300	300	300
Required storage/lane (feet):	250	250	250		150	150	150
PERMITTED LEFT TURNS:							
Opposing volume (pre-PHF):							
Opposing sat. flow rate:							
CALCULATIONS:							
Opposing flow ratio (Yo):							
Unblocked G/C:							
Effective red interval (sec):							
Average total queue (veh):							
Maximum total queue (veh):							
Total queue length (feet):							
Required storage/lane (feet):							

METHODOLOGY AND FORMULAS USED:

Length of red interval = $(1 - G/C) * \text{Cycle length}$

Average queue/lane = $\text{Volume} * \text{Red Interval} / 3600$

Maximum queue: Random arrival/Constant service

Random arrivals behave according to a Poisson distribution.

There is a probability equal to the confidence level desired (e.g. 95%)

that the queue formed during each red interval will be less than or equal to the maximum queue.

(Prob. of arrivals = N) = $(\text{Red Interval})^N * \exp(-N) / N!$ (the Poisson distribution)

(Prob. of arrivals \geq N) = $1 - \text{Sum of probabilities for vehicles } 0, 1, \dots, N-1$

Max N: Highest N such that the sum of probabilities $>$ (1 - confidence level)

Queue length = $\text{Maximum queue} * \text{Storage length per vehicle}$

Required storage per lane = $\text{Queue length} / \text{Number of lanes}$, rounded up to the next highest whole vehicle

Opposing flow ratio Yo = $\text{opposing volume } v_o / \text{opposing sat. flow rate } s_{op}$

Unblocked G/C (gu/C) = $(g/C - Y_o) / (1 - Y_o)$

Intersection: 12: Tualatin Sherwood Rd & I-5 SB Ramps

Movement	EB	EB	EB	EB	WB	WB	WB	SB	SB	SB	SB
Directions Served	T	T	T	R	L	T	T	L	LT	R	R
Maximum Queue (ft)	445	482	482	299	653	651	680	274	654	570	440
Average Queue (ft)	193	214	224	43	275	371	393	196	348	281	203
95th Queue (ft)	342	374	385	164	614	671	659	296	631	476	355
Link Distance (ft)	522	522	522	522	616	616	616		1139	1139	
Upstream Blk Time (%)	0	0	0		4	3	2				
Queuing Penalty (veh)	0	1	1		19	12	11				
Storage Bay Dist (ft)								200			700
Storage Blk Time (%)								7	25	0	
Queuing Penalty (veh)								23	79	0	

Intersection: 13: Tualatin Sherwood Rd & I-5 NB Ramps





















Movement	EB	EB	EB	WB	WB	WB	NB	NB	NB
Directions Served	T	T	R	T	T	R	L	LT	R
Maximum Queue (ft)	616	590	356	335	450	225	374	924	300
Average Queue (ft)	383	352	16	124	165	49	214	332	136
95th Queue (ft)	610	578	161	251	323	201	354	675	287
Link Distance (ft)	616	616	616	459	459			1328	
Upstream Blk Time (%)	0	0	0	0	0				
Queuing Penalty (veh)	1	1	0	0	1				
Storage Bay Dist (ft)						150	300		225
Storage Blk Time (%)					10	0	1	16	0
Queuing Penalty (veh)					64	0	6	90	1

Appendix G
Year 2014 Operations
Worksheets (for Alternative
Access Scenario)

HCM Signalized Intersection Capacity Analysis

1: Lower Boones Ferry Road & SW Upper Boones Ferry Road















4/15/2013

												
Movement	EBL	EBT	EBR	WBL	WBT	WBR	NBL	NBT	NBR	SBL	SBT	SBR
Lane Configurations												
Volume (vph)	1	7	9	479	7	40	0	504	567	59	697	1
Ideal Flow (vphpl)	1900	1900	1900	1900	1900	1900	1900	1900	1900	1900	1900	1900
Total Lost time (s)		3.5		3.5	3.5			4.0	3.5	3.5	4.0	
Lane Util. Factor		1.00		1.00	1.00			1.00	1.00	1.00	1.00	
Frbp, ped/bikes		0.92		1.00	0.95			1.00	0.98	1.00	1.00	
Flpb, ped/bikes		1.00		1.00	1.00			1.00	1.00	1.00	1.00	
Frt		0.93		1.00	0.87			1.00	0.85	1.00	1.00	
Flt Protected		1.00		0.95	1.00			1.00	1.00	0.95	1.00	
Satd. Flow (prot)		1596		1787	1574			1900	1570	1805	1900	
Flt Permitted		1.00		0.95	1.00			1.00	1.00	0.95	1.00	
Satd. Flow (perm)		1596		1787	1574			1900	1570	1805	1900	
Peak-hour factor, PHF	0.95	0.95	0.95	0.95	0.95	0.95	0.95	0.95	0.95	0.95	0.95	0.95
Adj. Flow (vph)	1	7	9	504	7	42	0	531	597	62	734	1
RTOR Reduction (vph)	0	9	0	0	26	0	0	0	158	0	0	0
Lane Group Flow (vph)	0	8	0	504	23	0	0	531	439	62	735	0
Confl. Peds. (#/hr)	15		7	7		15	7		8	8		7
Heavy Vehicles (%)	0%	2%	1%	1%	3%	0%	2%	0%	1%	0%	0%	0%
Turn Type	Split			Split			Prot		pm+ov		Prot	
Protected Phases	8	8		4	4		1	6	4	5	2	
Permitted Phases									6			
Actuated Green, G (s)		1.7		31.9	31.9			29.5	61.4	5.3	38.8	
Effective Green, g (s)		2.2		32.4	32.4			30.0	62.4	5.8	39.3	
Actuated g/C Ratio		0.03		0.38	0.38			0.35	0.73	0.07	0.46	
Clearance Time (s)		4.0		4.0	4.0			4.5	4.0	4.0	4.5	
Vehicle Extension (s)		2.5		2.2	2.2			3.5	2.2	2.2	3.5	
Lane Grp Cap (vph)		41		682	601			671	1154	123	880	
v/s Ratio Prot		c0.01		c0.28	0.01			0.28	0.15	0.03	c0.39	
v/s Ratio Perm									0.13			
v/c Ratio		0.20		0.74	0.04			0.79	0.38	0.50	0.84	
Uniform Delay, d1		40.5		22.6	16.5			24.6	4.1	38.2	20.0	
Progression Factor		1.00		1.00	1.00			1.00	1.00	1.00	1.00	
Incremental Delay, d2		1.8		3.8	0.0			6.5	0.1	1.7	7.1	
Delay (s)		42.2		26.4	16.5			31.2	4.2	39.8	27.0	
Level of Service		D		C	B			C	A	D	C	
Approach Delay (s)		42.2			25.5			16.9			28.0	
Approach LOS		D			C			B			C	
Intersection Summary												
HCM Average Control Delay			22.5			HCM Level of Service				C		
HCM Volume to Capacity ratio			0.77									
Actuated Cycle Length (s)			84.9			Sum of lost time (s)			11.0			
Intersection Capacity Utilization			83.3%			ICU Level of Service				E		
Analysis Period (min)			15									
c Critical Lane Group												

HCM Signalized Intersection Capacity Analysis

2: SW Boones Ferry Rd & SW Tualatin Rd

4/15/2013

						
Movement	WBL	WBR	NBT	NBR	SBL	SBT
Lane Configurations	 			 	 	
Volume (vph)	410	844	200	298	453	365
Ideal Flow (vphpl)	1900	1900	1900	1900	1900	1900
Total Lost time (s)	3.5	3.5	3.0	3.5	3.5	3.5
Lane Util. Factor	0.97	1.00	1.00	1.00	1.00	1.00
Frbp, ped/bikes	1.00	0.98	1.00	0.98	1.00	1.00
Flpb, ped/bikes	1.00	1.00	1.00	1.00	1.00	1.00
Frt	1.00	0.85	1.00	0.85	1.00	1.00
Flt Protected	0.95	1.00	1.00	1.00	0.95	1.00
Satd. Flow (prot)	3467	1590	1900	1574	1805	1900
Flt Permitted	0.95	1.00	1.00	1.00	0.95	1.00
Satd. Flow (perm)	3467	1590	1900	1574	1805	1900
Peak-hour factor, PHF	0.95	0.95	0.95	0.95	0.95	0.95
Adj. Flow (vph)	432	888	211	314	477	384
RTOR Reduction (vph)	0	182	0	75	0	0
Lane Group Flow (vph)	432	706	211	239	477	384
Confl. Peds. (#/hr)	7	15		8	8	
Heavy Vehicles (%)	1%	0%	0%	1%	0%	0%
Turn Type		pm+ov		pm+ov	Prot	
Protected Phases	8	1	2	8	1	6
Permitted Phases		8		2		
Actuated Green, G (s)	11.4	32.2	10.7	22.1	20.8	35.0
Effective Green, g (s)	11.9	33.2	11.2	23.1	21.3	35.5
Actuated g/C Ratio	0.22	0.61	0.21	0.42	0.39	0.65
Clearance Time (s)	4.0	4.0	3.5	4.0	4.0	4.0
Vehicle Extension (s)	3.0	2.0	5.0	3.0	2.0	2.0
Lane Grp Cap (vph)	758	1073	391	668	707	1240
v/s Ratio Prot	0.12	c0.26	c0.11	0.08	0.26	0.20
v/s Ratio Perm		0.19		0.07		
v/c Ratio	0.57	0.66	0.54	0.36	0.67	0.31
Uniform Delay, d1	19.0	6.9	19.3	10.6	13.7	4.1
Progression Factor	1.00	1.00	1.00	1.00	1.00	1.00
Incremental Delay, d2	1.0	1.1	2.6	0.3	2.0	0.1
Delay (s)	20.0	8.0	21.9	10.9	15.7	4.2
Level of Service	B	A	C	B	B	A
Approach Delay (s)	11.9		15.4			10.6
Approach LOS	B		B			B
Intersection Summary						
HCM Average Control Delay			12.2		HCM Level of Service	B
HCM Volume to Capacity ratio			0.63			
Actuated Cycle Length (s)			54.4		Sum of lost time (s)	6.5
Intersection Capacity Utilization			72.2%		ICU Level of Service	C
Analysis Period (min)			15			
c Critical Lane Group						

HCM Signalized Intersection Capacity Analysis

3: SW Boones Fe & SW Martinazzi Ave





















4/15/2013

	→	↘	↙	←	↖	↗
Movement	EBT	EBR	WBL	WBT	NBL	NBR
Lane Configurations	↑	↗	↘	↑	↘	↗
Volume (vph)	674	175	453	930	335	385
Ideal Flow (vphpl)	1900	1900	1900	1900	1900	1900
Total Lost time (s)	4.5	4.5	4.5	4.5	4.5	4.5
Lane Util. Factor	1.00	1.00	1.00	1.00	1.00	1.00
Frpb, ped/bikes	1.00	1.00	1.00	1.00	1.00	0.98
Flpb, ped/bikes	1.00	1.00	1.00	1.00	1.00	1.00
Fr t	1.00	0.85	1.00	1.00	1.00	0.85
Fl t Protected	1.00	1.00	0.95	1.00	0.95	1.00
Satd. Flow (prot)	1863	1599	1787	1845	1770	1571
Fl t Permitted	1.00	1.00	0.95	1.00	0.95	1.00
Satd. Flow (perm)	1863	1599	1787	1845	1770	1571
Peak-hour factor, PHF	0.95	0.95	0.95	0.95	0.95	0.95
Adj. Flow (vph)	709	184	477	979	353	405
RTOR Reduction (vph)	0	61	0	0	0	34
Lane Group Flow (vph)	709	123	477	979	353	371
Confl. Peds. (#/hr)		7	7		7	8
Heavy Vehicles (%)	2%	1%	1%	3%	2%	1%
Turn Type		Prot	Prot		pm+ov	
Protected Phases	2	2	1	6	8	1
Permitted Phases					8	8
Actuated Green, G (s)	42.2	42.2	33.1	80.3	24.1	57.2
Effective Green, g (s)	42.7	42.7	33.6	80.8	24.6	58.2
Actuated g/C Ratio	0.37	0.37	0.29	0.71	0.22	0.51
Clearance Time (s)	5.0	5.0	5.0	5.0	5.0	5.0
Vehicle Extension (s)	3.0	3.0	3.0	3.0	3.0	3.0
Lane Grp Cap (vph)	695	597	525	1303	381	861
v/s Ratio Prot	c0.38	0.08	c0.27	0.53	c0.20	0.13
v/s Ratio Perm						0.11
v/c Ratio	1.02	0.21	0.91	0.75	0.93	0.43
Uniform Delay, d1	35.9	24.3	38.9	10.5	44.0	17.7
Progression Factor	1.00	1.00	1.00	1.00	1.00	1.00
Incremental Delay, d2	39.3	0.2	19.4	2.5	28.1	0.3
Delay (s)	75.2	24.5	58.4	13.0	72.1	18.0
Level of Service	E	C	E	B	E	B
Approach Delay (s)	64.7			27.9	43.2	
Approach LOS	E			C	D	
Intersection Summary						
HCM Average Control Delay			42.2		HCM Level of Service	D
HCM Volume to Capacity ratio			0.96			
Actuated Cycle Length (s)			114.4		Sum of lost time (s)	13.5
Intersection Capacity Utilization			90.4%		ICU Level of Service	E
Analysis Period (min)			15			
c Critical Lane Group						

HCM Signalized Intersection Capacity Analysis

5: Seneca St & Martinazzi Ave





















4/15/2013

													
Movement	EBL	EBT	EBR	WBL	WBT	WBR	NBL	NBT	NBR	SBL	SBT	SBR	
Lane Configurations													
Volume (vph)	40	0	80	53	0	163	85	516	99	202	376	50	
Ideal Flow (vphpl)	1900	1900	1900	1900	1900	1900	1900	1900	1900	1900	1900	1900	
Total Lost time (s)	3.5	3.5			3.5	3.5	3.5	3.5		3.5	3.5		
Lane Util. Factor	1.00	1.00			1.00	1.00	1.00	1.00		1.00	1.00		
Frbp, ped/bikes	1.00	0.97			1.00	0.97	1.00	1.00		1.00	1.00		
Flpb, ped/bikes	0.96	1.00			0.99	1.00	1.00	1.00		1.00	1.00		
Frt	1.00	0.85			1.00	0.85	1.00	0.98		1.00	0.98		
Flt Protected	0.95	1.00			0.95	1.00	0.95	1.00		0.95	1.00		
Satd. Flow (prot)	1739	1573			1747	1540	1802	1825		1769	1828		
Flt Permitted	0.72	1.00			0.70	1.00	0.47	1.00		0.20	1.00		
Satd. Flow (perm)	1317	1573			1287	1540	895	1825		370	1828		
Peak-hour factor, PHF	0.91	0.92	0.91	0.92	0.92	0.92	0.91	0.91	0.92	0.92	0.91	0.91	
Adj. Flow (vph)	44	0	88	58	0	177	93	567	108	220	413	55	
RTOR Reduction (vph)	0	76	0	0	0	127	0	9	0	0	6	0	
Lane Group Flow (vph)	44	12	0	0	58	50	93	667	0	220	462	0	
Confl. Peds. (#/hr)	26		16	16		26	5		5	5		5	
Heavy Vehicles (%)	0%	2%	0%	2%	2%	2%	0%	1%	2%	2%	2%	0%	
Turn Type	Perm		Perm		pm+ov	pm+pt			pm+pt				
Protected Phases		4			8	1	5	2		1	6		
Permitted Phases	4			8		8	2			6			
Actuated Green, G (s)	5.9	5.9			5.9	12.8	27.8	23.8		33.6	26.7		
Effective Green, g (s)	6.4	6.4			6.4	13.8	28.8	24.3		34.6	27.2		
Actuated g/C Ratio	0.13	0.13			0.13	0.28	0.59	0.50		0.71	0.56		
Clearance Time (s)	4.0	4.0			4.0	4.0	4.0	4.0		4.0	4.0		
Vehicle Extension (s)	3.0	3.0			3.0	3.0	3.0	3.0		3.0	3.0		
Lane Grp Cap (vph)	173	207			169	548	614	913		476	1023		
v/s Ratio Prot		0.01				0.01	0.01	c0.37		c0.07	0.25		
v/s Ratio Perm	0.03				c0.05	0.02	0.08			0.26			
v/c Ratio	0.25	0.06			0.34	0.09	0.15	0.73		0.46	0.45		
Uniform Delay, d1	19.0	18.5			19.2	12.8	4.3	9.6		5.1	6.3		
Progression Factor	1.00	1.00			1.00	1.00	1.00	1.00		1.00	1.00		
Incremental Delay, d2	0.8	0.1			1.2	0.1	0.1	3.0		0.7	0.3		
Delay (s)	19.7	18.6			20.4	12.9	4.4	12.6		5.8	6.6		
Level of Service	B	B			C	B	A	B		A	A		
Approach Delay (s)		19.0			14.7			11.6			6.4		
Approach LOS		B			B			B			A		
Intersection Summary													
HCM Average Control Delay			10.6									HCM Level of Service	B
HCM Volume to Capacity ratio			0.68										
Actuated Cycle Length (s)			48.6									Sum of lost time (s)	14.0
Intersection Capacity Utilization			66.2%									ICU Level of Service	C
Analysis Period (min)			15										
c Critical Lane Group													

HCM Signalized Intersection Capacity Analysis

8: Nyberg St & Martinazzi Ave

4/15/2013

												
Movement	EBL	EBT	EBR	WBL	WBT	WBR	NBL	NBT	NBR	SBL	SBT	SBR
Lane Configurations												
Volume (vph)	29	10	100	357	55	337	27	315	26	0	499	10
Ideal Flow (vphpl)	1900	1900	1900	1900	1900	1900	1900	1900	1900	1900	1900	1900
Total Lost time (s)	4.0	4.0		4.0	4.0	4.0	4.0	4.0			4.0	
Lane Util. Factor	1.00	1.00		0.95	0.95	1.00	1.00	1.00			0.95	
Frbp, ped/bikes	1.00	1.00		1.00	1.00	0.97	1.00	1.00			1.00	
Flpb, ped/bikes	1.00	1.00		1.00	1.00	1.00	1.00	1.00			1.00	
Frt	1.00	0.86		1.00	1.00	0.85	1.00	0.99			1.00	
Flt Protected	0.95	1.00		0.95	0.96	1.00	0.95	1.00			1.00	
Satd. Flow (prot)	1805	1626		1698	1728	1533	1682	1855			3563	
Flt Permitted	0.95	1.00		0.95	0.96	1.00	0.40	1.00			1.00	
Satd. Flow (perm)	1805	1626		1698	1728	1533	701	1855			3563	
Peak-hour factor, PHF	0.91	0.91	0.91	0.91	0.91	0.91	0.91	0.91	0.91	0.91	0.91	0.91
Adj. Flow (vph)	32	11	110	392	60	370	30	346	29	0	548	11
RTOR Reduction (vph)	0	96	0	0	0	276	0	4	0	0	2	0
Lane Group Flow (vph)	32	25	0	223	229	94	30	371	0	0	557	0
Confl. Peds. (#/hr)	10					10	6		19	19		6
Heavy Vehicles (%)	0%	0%	1%	1%	0%	2%	7%	1%	0%	0%	1%	0%
Turn Type	Split			Split			Perm	Perm				
Protected Phases	8	8		4	4			6			2	
Permitted Phases						4	6					
Actuated Green, G (s)	4.8	4.8		10.3	10.3	10.3	13.7	13.7			13.7	
Effective Green, g (s)	5.3	5.3		10.8	10.8	10.8	14.2	14.2			14.2	
Actuated g/C Ratio	0.13	0.13		0.26	0.26	0.26	0.34	0.34			0.34	
Clearance Time (s)	4.5	4.5		4.5	4.5	4.5	4.5	4.5			4.5	
Vehicle Extension (s)	2.5	2.5		2.5	2.5	2.5	5.0	5.0			5.0	
Lane Grp Cap (vph)	226	204		434	441	391	235	623			1196	
v/s Ratio Prot	c0.02	0.02		0.13	c0.13			c0.20			0.16	
v/s Ratio Perm						0.06	0.04					
v/c Ratio	0.14	0.12		0.51	0.52	0.24	0.13	0.60			0.47	
Uniform Delay, d1	16.5	16.4		13.5	13.5	12.5	9.8	11.7			11.1	
Progression Factor	1.00	1.00		1.00	1.00	1.00	1.00	1.00			1.00	
Incremental Delay, d2	0.2	0.2		0.8	0.8	0.2	0.5	2.3			0.6	
Delay (s)	16.7	16.6		14.3	14.3	12.7	10.3	14.0			11.7	
Level of Service	B	B		B	B	B	B	B			B	
Approach Delay (s)		16.6			13.6			13.7			11.7	
Approach LOS		B			B			B			B	
Intersection Summary												
HCM Average Control Delay			13.3								HCM Level of Service	B
HCM Volume to Capacity ratio			0.49									
Actuated Cycle Length (s)			42.3								Sum of lost time (s)	12.0
Intersection Capacity Utilization			56.9%								ICU Level of Service	B
Analysis Period (min)			15									
c Critical Lane Group												

HCM Unsignalized Intersection Capacity Analysis

9: Nyberg St & Site Entrance 3



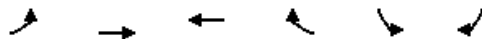





















4/15/2013



Movement	EBL	EBT	WBT	WBR	SBL	SBR
Lane Configurations	↶		↶↷			↷
Volume (veh/h)	35	0	648	51	0	100
Sign Control		Free	Free		Stop	
Grade		0%	0%		0%	
Peak Hour Factor	0.88	0.88	0.88	0.88	0.88	0.88
Hourly flow rate (vph)	40	0	736	58	0	114
Pedestrians					5	
Lane Width (ft)					12.0	
Walking Speed (ft/s)					4.0	
Percent Blockage					0	
Right turn flare (veh)						
Median type		None	None			
Median storage (veh)						
Upstream signal (ft)		278				
pX, platoon unblocked						
vC, conflicting volume	799				850	402
vC1, stage 1 conf vol						
vC2, stage 2 conf vol						
vCu, unblocked vol	799				850	402
tC, single (s)	4.1				6.8	6.9
tC, 2 stage (s)						
tF (s)	2.2				3.5	3.3
p0 queue free %	95				100	81
cM capacity (veh/h)	829				288	601
Direction, Lane #	EB 1	WB 1	WB 2	SB 1		
Volume Total	40	491	303	114		
Volume Left	40	0	0	0		
Volume Right	0	0	58	114		
cSH	829	1700	1700	601		
Volume to Capacity	0.05	0.29	0.18	0.19		
Queue Length 95th (ft)	4	0	0	17		
Control Delay (s)	9.6	0.0	0.0	12.4		
Lane LOS	A			B		
Approach Delay (s)	9.6	0.0		12.4		
Approach LOS				B		
Intersection Summary						
Average Delay			1.9			
Intersection Capacity Utilization			32.4%		ICU Level of Service	A
Analysis Period (min)			15			

HCM Signalized Intersection Capacity Analysis
 10: Tualatin Sherwood Rd & Site Entrance 4













4/15/2013

												
Movement	EBL	EBT	EBR	WBL	WBT	WBR	NBL	NBT	NBR	SBL	SBT	SBR
Lane Configurations		 		 	 					 		
Volume (vph)	99	1899	40	232	1694	251	36	10	236	323	24	113
Ideal Flow (vphpl)	1900	1900	1900	1900	1900	1900	1900	1900	1900	1900	1900	1900
Total Lost time (s)	4.5	6.0		4.5	6.0	6.0		5.0	4.5	5.0	5.0	
Lane Util. Factor	1.00	*0.75		0.97	0.91	1.00		1.00	1.00	0.97	1.00	
Frbp, ped/bikes	1.00	1.00		1.00	1.00	0.96		1.00	1.00	1.00	0.97	
Flpb, ped/bikes	1.00	1.00		1.00	1.00	1.00		1.00	1.00	1.00	1.00	
Frt	1.00	1.00		1.00	1.00	0.85		1.00	0.85	1.00	0.88	
Flt Protected	0.95	1.00		0.95	1.00	1.00		0.96	1.00	0.95	1.00	
Satd. Flow (prot)	1805	4100		3502	4988	1545		1786	1599	3502	1622	
Flt Permitted	0.95	1.00		0.95	1.00	1.00		0.96	1.00	0.95	1.00	
Satd. Flow (perm)	1805	4100		3502	4988	1545		1786	1599	3502	1622	
Peak-hour factor, PHF	0.98	0.98	0.98	0.98	0.98	0.98	0.98	0.98	0.98	0.98	0.98	0.98
Adj. Flow (vph)	101	1938	41	237	1729	256	37	10	241	330	24	115
RTOR Reduction (vph)	0	1	0	0	0	126	0	0	0	0	99	0
Lane Group Flow (vph)	101	1978	0	237	1729	130	0	47	241	330	40	0
Confl. Peds. (#/hr)			2			8						15
Heavy Vehicles (%)	0%	4%	0%	0%	4%	0%	3%	0%	1%	0%	0%	0%
Turn Type	Prot			Prot		Perm	Split		pt+ov	Split		
Protected Phases	5	2		1	6		8	8	18	4	4	
Permitted Phases						6						
Actuated Green, G (s)	14.1	61.1		16.1	63.1	63.1		8.6	24.7	16.7	16.7	
Effective Green, g (s)	14.6	61.6		16.6	63.6	63.6		9.1	25.7	17.2	17.2	
Actuated g/C Ratio	0.12	0.49		0.13	0.51	0.51		0.07	0.21	0.14	0.14	
Clearance Time (s)	5.0	6.5		5.0	6.5	6.5		5.5		5.5	5.5	
Vehicle Extension (s)	2.5	4.0		2.5	4.0	4.0		2.5		2.5	2.5	
Lane Grp Cap (vph)	211	2020		465	2538	786		130	329	482	223	
v/s Ratio Prot	0.06	c0.48		0.07	0.35			0.03	c0.15	c0.09	0.02	
v/s Ratio Perm						0.08						
v/c Ratio	0.48	0.98		0.51	0.68	0.17		0.36	0.73	0.68	0.18	
Uniform Delay, d1	51.6	31.1		50.4	23.1	16.5		55.2	46.4	51.3	47.7	
Progression Factor	0.88	0.56		1.04	0.86	1.12		1.00	1.00	1.00	1.00	
Incremental Delay, d2	0.6	9.4		0.4	1.0	0.3		1.2	7.7	3.7	0.3	
Delay (s)	46.2	26.6		53.0	20.9	18.7		56.4	54.2	55.0	47.9	
Level of Service	D	C		D	C	B		E	D	D	D	
Approach Delay (s)		27.6			24.1			54.5			52.9	
Approach LOS		C			C			D			D	
Intersection Summary												
HCM Average Control Delay			29.9			HCM Level of Service				C		
HCM Volume to Capacity ratio			0.83									
Actuated Cycle Length (s)			125.0			Sum of lost time (s)			15.5			
Intersection Capacity Utilization			81.5%			ICU Level of Service				D		
Analysis Period (min)			15									
c Critical Lane Group												

HCM Signalized Intersection Capacity Analysis

12: Tualatin Sherwood Rd & I-5 SB Ramps

4/15/2013













												
Movement	EBL	EBT	EBR	WBL	WBT	WBR	NBL	NBT	NBR	SBL	SBT	SBR
Lane Configurations		↑↑↑	↗	↖	↑↑					↖	↗	↗↗
Volume (vph)	0	1590	875	123	1063	0	0	0	0	659	5	1111
Ideal Flow (vphpl)	1900	1900	1900	1900	1900	1900	1900	1900	1900	1900	1900	1900
Total Lost time (s)		5.5	5.5	5.5	5.5					5.5	5.5	5.5
Lane Util. Factor		*0.75	1.00	1.00	0.95					0.95	0.95	0.88
Flt		1.00	0.85	1.00	1.00					1.00	1.00	0.85
Flt Protected		1.00	1.00	0.95	1.00					0.95	0.95	1.00
Satd. Flow (prot)		4150	1568	1787	3471					1681	1682	2760
Flt Permitted		1.00	1.00	0.95	1.00					0.95	0.95	1.00
Satd. Flow (perm)		4150	1568	1787	3471					1681	1682	2760
Peak-hour factor, PHF	0.99	0.99	0.99	0.99	0.99	0.99	0.99	0.99	0.99	0.99	0.99	0.99
Adj. Flow (vph)	0	1606	884	124	1074	0	0	0	0	666	5	1122
RTOR Reduction (vph)	0	0	476	0	0	0	0	0	0	0	0	23
Lane Group Flow (vph)	0	1606	408	124	1074	0	0	0	0	333	338	1099
Heavy Vehicles (%)	0%	3%	3%	1%	4%	0%	0%	0%	0%	2%	20%	3%
Turn Type			Perm	Prot						Split		custom
Protected Phases		2		1	6					4	4	4.5
Permitted Phases			2									
Actuated Green, G (s)		56.5	56.5	11.1	51.5					39.4	39.4	61.5
Effective Green, g (s)		57.0	57.0	11.6	52.0					39.9	39.9	62.0
Actuated g/C Ratio		0.46	0.46	0.09	0.42					0.32	0.32	0.50
Clearance Time (s)		6.0	6.0	6.0	6.0					6.0	6.0	
Vehicle Extension (s)		6.1	6.1	2.3	6.1					2.3	2.3	
Lane Grp Cap (vph)		1892	715	166	1444					537	537	1369
v/s Ratio Prot		c0.39		0.07	c0.31					0.20	0.20	c0.40
v/s Ratio Perm			0.26									
v/c Ratio		0.85	0.57	0.75	0.74					0.62	0.63	0.80
Uniform Delay, d1		30.2	25.0	55.3	30.9					36.1	36.3	26.4
Progression Factor		0.50	2.46	0.79	0.64					1.00	1.00	1.00
Incremental Delay, d2		2.5	1.6	14.5	3.3					1.8	1.9	3.4
Delay (s)		17.6	63.1	58.3	23.1					37.9	38.1	29.8
Level of Service		B	E	E	C					D	D	C
Approach Delay (s)		33.7			26.8			0.0			32.8	
Approach LOS		C			C			A			C	
Intersection Summary												
HCM Average Control Delay			31.9		HCM Level of Service					C		
HCM Volume to Capacity ratio			0.82									
Actuated Cycle Length (s)			125.0		Sum of lost time (s)			11.0				
Intersection Capacity Utilization			93.1%		ICU Level of Service			F				
Analysis Period (min)			15									

c Critical Lane Group

HCM Signalized Intersection Capacity Analysis





















13: Tualatin Sherwood Rd & I-5 NB Ramps

4/15/2013

												
Movement	EBL	EBT	EBR	WBL	WBT	WBR	NBL	NBT	NBR	SBL	SBT	SBR
Lane Configurations		↑↑	↑↑		↑↑	↑	↑	↑	↑			
Volume (vph)	0	1216	1031	0	511	682	675	5	177	0	0	0
Ideal Flow (vphpl)	1900	1900	1900	1900	1900	1900	1900	1900	1900	1900	1900	1900
Total Lost time (s)		5.5	5.5		6.0	6.0	5.5	5.5	5.5			
Lane Util. Factor		0.95	0.88		0.95	1.00	0.95	0.95	1.00			
Frbp, ped/bikes		1.00	1.00		1.00	0.95	1.00	1.00	0.96			
Flpb, ped/bikes		1.00	1.00		1.00	1.00	1.00	1.00	1.00			
Frt		1.00	0.85		1.00	0.85	1.00	1.00	0.85			
Flt Protected		1.00	1.00		1.00	1.00	0.95	0.95	1.00			
Satd. Flow (prot)		3574	2760		3574	1502	1618	1620	1512			
Flt Permitted		1.00	1.00		1.00	1.00	0.95	0.95	1.00			
Satd. Flow (perm)		3574	2760		3574	1502	1618	1620	1512			
Peak-hour factor, PHF	0.95	0.95	0.95	0.95	0.95	0.95	0.95	0.95	0.95	0.95	0.95	0.95
Adj. Flow (vph)	0	1280	1085	0	538	718	711	5	186	0	0	0
RTOR Reduction (vph)	0	0	352	0	0	263	0	0	21	0	0	0
Lane Group Flow (vph)	0	1280	733	0	538	455	355	361	165	0	0	0
Confl. Peds. (#/hr)						16			17			
Heavy Vehicles (%)	0%	1%	3%	0%	1%	2%	6%	20%	2%	0%	0%	0%
Turn Type			Perm			Perm	Split		Perm			
Protected Phases		2			6		8	8				
Permitted Phases			2			6			8			
Actuated Green, G (s)		79.3	79.3		78.8	78.8	33.7	33.7	33.7			
Effective Green, g (s)		79.8	79.8		79.3	79.3	34.2	34.2	34.2			
Actuated g/C Ratio		0.64	0.64		0.63	0.63	0.27	0.27	0.27			
Clearance Time (s)		6.0	6.0		6.5	6.5	6.0	6.0	6.0			
Vehicle Extension (s)		6.1	6.1		4.2	4.2	2.3	2.3	2.3			
Lane Grp Cap (vph)		2282	1762		2267	953	443	443	414			
v/s Ratio Prot		c0.36			0.15		0.22	c0.22				
v/s Ratio Perm			0.27			0.30			0.11			
v/c Ratio		0.56	0.42		0.24	0.48	0.80	0.81	0.40			
Uniform Delay, d1		12.7	11.1		9.8	12.0	42.2	42.4	37.0			
Progression Factor		0.72	1.20		1.00	1.00	1.00	1.00	1.00			
Incremental Delay, d2		0.7	0.5		0.2	1.7	9.6	10.6	0.4			
Delay (s)		9.9	13.8		10.1	13.7	51.9	53.1	37.4			
Level of Service		A	B		B	B	D	D	D			
Approach Delay (s)		11.7			12.2			49.4			0.0	
Approach LOS		B			B			D			A	
Intersection Summary												
HCM Average Control Delay			19.3									B
HCM Volume to Capacity ratio			0.64									
Actuated Cycle Length (s)			125.0						11.0			
Intersection Capacity Utilization			72.2%									C
Analysis Period (min)			15									
c Critical Lane Group												





















HCM Signalized Intersection Capacity Analysis
 14: Tualatin Sherwood Rd & Nyberg Woods

4/15/2013

												
Movement	EBL	EBT	EBR	WBL	WBT	WBR	NBL	NBT	NBR	SBL	SBT	SBR
Lane Configurations												
Volume (vph)	290	995	61	10	834	80	112	7	17	81	5	191
Ideal Flow (vphpl)	1900	1900	1900	1900	1900	1900	1900	1900	1900	1900	1900	1900
Total Lost time (s)	5.5	5.5		5.5	5.5			5.5	5.5		5.5	5.5
Lane Util. Factor	0.97	0.95		1.00	0.95			1.00	1.00		1.00	1.00
Frbp, ped/bikes	1.00	1.00		1.00	1.00			1.00	0.98		1.00	0.99
Flpb, ped/bikes	1.00	1.00		1.00	1.00			1.00	1.00		1.00	1.00
Frt	1.00	0.99		1.00	0.99			1.00	0.85		1.00	0.85
Flt Protected	0.95	1.00		0.95	1.00			0.95	1.00		0.95	1.00
Satd. Flow (prot)	3502	3504		1805	3525			1761	1590		1793	1592
Flt Permitted	0.95	1.00		0.95	1.00			0.67	1.00		0.65	1.00
Satd. Flow (perm)	3502	3504		1805	3525			1243	1590		1221	1592
Peak-hour factor, PHF	0.96	0.96	0.96	0.96	0.96	0.96	0.96	0.96	0.96	0.96	0.96	0.96
Adj. Flow (vph)	302	1036	64	10	869	83	117	7	18	84	5	199
RTOR Reduction (vph)	0	3	0	0	7	0	0	0	15	0	0	165
Lane Group Flow (vph)	302	1097	0	10	945	0	0	124	3	0	89	34
Confl. Peds. (#/hr)	9		2	2		9	3		4	4		3
Heavy Vehicles (%)	0%	2%	2%	0%	1%	0%	3%	0%	0%	1%	0%	0%
Turn Type	Prot			Prot			Perm		Perm	Perm		Perm
Protected Phases	5	2		1	6			8				4
Permitted Phases							8		8	4		4
Actuated Green, G (s)	9.0	33.1		0.7	24.8			10.2	10.2		10.2	10.2
Effective Green, g (s)	9.5	33.6		1.2	25.3			10.7	10.7		10.7	10.7
Actuated g/C Ratio	0.15	0.54		0.02	0.41			0.17	0.17		0.17	0.17
Clearance Time (s)	6.0	6.0		6.0	6.0			6.0	6.0		6.0	6.0
Vehicle Extension (s)	2.3	2.5		2.4	2.5			2.4	2.4		2.3	2.3
Lane Grp Cap (vph)	537	1899		35	1438			215	274		211	275
v/s Ratio Prot	c0.09	c0.31		0.01	c0.27							
v/s Ratio Perm								c0.10	0.00		0.07	0.02
v/c Ratio	0.56	0.58		0.29	0.66			0.58	0.01		0.42	0.12
Uniform Delay, d1	24.3	9.5		30.0	14.8			23.6	21.3		22.9	21.7
Progression Factor	1.00	1.00		1.00	1.00			1.00	1.00		1.00	1.00
Incremental Delay, d2	1.0	0.4		2.9	1.0			2.9	0.0		0.8	0.1
Delay (s)	25.3	9.8		32.9	15.8			26.5	21.3		23.7	21.8
Level of Service	C	A		C	B			C	C		C	C
Approach Delay (s)		13.2			16.0			25.8			22.4	
Approach LOS		B			B			C			C	
Intersection Summary												
HCM Average Control Delay			15.7			HCM Level of Service				B		
HCM Volume to Capacity ratio			0.71									
Actuated Cycle Length (s)			62.0			Sum of lost time (s)			22.0			
Intersection Capacity Utilization			61.6%			ICU Level of Service			B			
Analysis Period (min)			15									
c Critical Lane Group												



























HCM Signalized Intersection Capacity Analysis
 15: SW Nyberg St & SW Nyberg St

4/15/2013

												
Movement	EBL	EBT	EBR	WBL	WBT	WBR	NBL	NBT	NBR	SBL	SBT	SBR
Lane Configurations												
Volume (vph)	221	943	26	24	775	16	17	9	45	5	7	139
Ideal Flow (vphpl)	1900	1900	1900	1900	1900	1900	1900	1900	1900	1900	1900	1900
Total Lost time (s)	4.8	4.8		4.8	4.8			5.6	5.6		5.3	4.8
Lane Util. Factor	1.00	1.00		1.00	0.95			1.00	1.00		1.00	1.00
Frbp, ped/bikes	1.00	1.00		1.00	1.00			1.00	0.95		1.00	1.00
Flpb, ped/bikes	1.00	1.00		1.00	1.00			1.00	1.00		1.00	1.00
Frt	1.00	1.00		1.00	1.00			1.00	0.85		1.00	0.85
Flt Protected	0.95	1.00		0.95	1.00			0.97	1.00		0.98	1.00
Satd. Flow (prot)	1805	1854		1805	3561			1803	1527		1848	1609
Flt Permitted	0.95	1.00		0.95	1.00			0.97	1.00		0.69	1.00
Satd. Flow (perm)	1805	1854		1805	3561			1803	1527		1304	1609
Peak-hour factor, PHF	0.96	0.96	0.96	0.96	0.96	0.96	0.96	0.96	0.96	0.96	0.96	0.96
Adj. Flow (vph)	230	982	27	25	807	17	18	9	47	5	7	145
RTOR Reduction (vph)	0	0	0	0	1	0	0	0	44	0	0	116
Lane Group Flow (vph)	230	1009	0	25	823	0	0	27	3	0	12	29
Confl. Peds. (#/hr)	9		2	2		9	3		4	4		3
Heavy Vehicles (%)	0%	2%	2%	0%	1%	0%	3%	0%	0%	1%	0%	0%
Turn Type	Prot			Prot			Split		Perm	Perm		pm+ov
Protected Phases	5	2		1	6		8	8			4	5
Permitted Phases									8	4		4
Actuated Green, G (s)	11.5	48.8		1.7	39.0			4.1	4.1		3.6	15.1
Effective Green, g (s)	12.0	49.3		2.2	39.5			4.6	4.6		4.1	16.1
Actuated g/C Ratio	0.15	0.61		0.03	0.49			0.06	0.06		0.05	0.20
Clearance Time (s)	5.3	5.3		5.3	5.3			6.1	6.1		5.8	5.3
Vehicle Extension (s)	2.5	3.0		1.0	3.0			1.0	1.0		2.0	2.5
Lane Grp Cap (vph)	268	1133		49	1743			103	87		66	321
v/s Ratio Prot	c0.13	c0.54		0.01	0.23			c0.01				0.01
v/s Ratio Perm									0.00		c0.01	0.00
v/c Ratio	0.86	0.89		0.51	0.47			0.26	0.03		0.18	0.09
Uniform Delay, d1	33.5	13.4		38.7	13.7			36.4	35.9		36.7	26.3
Progression Factor	1.00	1.00		1.00	1.00			1.00	1.00		1.00	1.00
Incremental Delay, d2	22.5	9.0		3.7	0.2			0.5	0.1		0.5	0.1
Delay (s)	56.1	22.4		42.4	13.9			36.9	36.0		37.2	26.4
Level of Service	E	C		D	B			D	D		D	C
Approach Delay (s)		28.6			14.7			36.3			27.2	
Approach LOS		C			B			D			C	
Intersection Summary												
HCM Average Control Delay			23.7			HCM Level of Service			C			
HCM Volume to Capacity ratio			0.83									
Actuated Cycle Length (s)			80.7			Sum of lost time (s)		20.5				
Intersection Capacity Utilization			76.8%			ICU Level of Service		D				
Analysis Period (min)			15									
c Critical Lane Group												























HCM Signalized Intersection Capacity Analysis
 16: SW Tualatin Sherwood Rd & SW Boones Ferry Rd

4/15/2013

												
Movement	EBL	EBT	EBR	WBL	WBT	WBR	NBL	NBT	NBR	SBL	SBT	SBR
Lane Configurations		 		 	 						 	
Volume (vph)	103	1035	138	234	1103	56	171	268	169	297	345	133
Ideal Flow (vphpl)	1900	1900	1900	1900	1900	1900	1900	1900	1900	1900	1900	1900
Total Lost time (s)	4.5	5.5		4.5	5.5		4.5	5.0	4.5	4.5	5.0	
Lane Util. Factor	1.00	0.95		0.97	0.95		1.00	1.00	1.00	1.00	0.95	
Frbp, ped/bikes	1.00	1.00		1.00	1.00		1.00	1.00	0.98	1.00	0.99	
Flpb, ped/bikes	1.00	1.00		1.00	1.00		1.00	1.00	1.00	1.00	1.00	
Frt	1.00	0.98		1.00	0.99		1.00	1.00	0.85	1.00	0.96	
Flt Protected	0.95	1.00		0.95	1.00		0.95	1.00	1.00	0.95	1.00	
Satd. Flow (prot)	1703	3320		3502	3339		1732	1810	1543	1761	3313	
Flt Permitted	0.95	1.00		0.95	1.00		0.41	1.00	1.00	0.59	1.00	
Satd. Flow (perm)	1703	3320		3502	3339		744	1810	1543	1099	3313	
Peak-hour factor, PHF	0.99	0.99	0.99	0.99	0.99	0.99	0.99	0.99	0.99	0.99	0.99	0.99
Adj. Flow (vph)	104	1045	139	236	1114	57	173	271	171	300	348	134
RTOR Reduction (vph)	0	7	0	0	3	0	0	0	55	0	34	0
Lane Group Flow (vph)	104	1177	0	236	1168	0	173	271	116	300	448	0
Confl. Peds. (#/hr)			7			15	7		8	8		7
Heavy Vehicles (%)	6%	7%	3%	0%	7%	6%	4%	5%	3%	2%	4%	3%
Turn Type	Prot			Prot			pm+pt		pm+ov		pm+pt	
Protected Phases	5	2		1	6		3	8	1	7	4	
Permitted Phases							8		8	4		
Actuated Green, G (s)	10.0	54.6		10.7	55.3		21.2	21.2	31.9	27.3	26.8	
Effective Green, g (s)	10.5	55.1		11.2	55.8		21.7	21.7	32.9	27.8	27.3	
Actuated g/C Ratio	0.08	0.44		0.09	0.45		0.17	0.17	0.26	0.22	0.22	
Clearance Time (s)	5.0	6.0		5.0	6.0		5.0	5.5	5.0	5.0	5.5	
Vehicle Extension (s)	2.0	3.5		2.0	3.5		2.0	2.0	2.0	2.0	2.0	
Lane Grp Cap (vph)	143	1463		314	1491		223	314	406	337	724	
v/s Ratio Prot	0.06	c0.35		0.07	c0.35		0.07	c0.15	0.03	c0.12	0.14	
v/s Ratio Perm							0.06		0.05	c0.07		
v/c Ratio	0.73	0.80		0.75	0.78		0.78	0.86	0.29	0.89	0.62	
Uniform Delay, d1	55.9	30.3		55.5	29.5		47.6	50.2	36.7	45.8	44.1	
Progression Factor	1.00	1.00		0.61	0.96		1.00	1.00	1.00	1.00	1.00	
Incremental Delay, d2	14.4	4.8		5.3	2.5		14.2	20.3	0.1	23.5	1.1	
Delay (s)	70.3	35.1		39.2	30.9		61.8	70.5	36.8	69.4	45.3	
Level of Service	E	D		D	C		E	E	D	E	D	
Approach Delay (s)		37.9			32.3			58.7			54.5	
Approach LOS		D			C			E			D	
Intersection Summary												
HCM Average Control Delay			42.3			HCM Level of Service				D		
HCM Volume to Capacity ratio			0.87									
Actuated Cycle Length (s)			125.0			Sum of lost time (s)			20.5			
Intersection Capacity Utilization			88.2%			ICU Level of Service			E			
Analysis Period (min)			15									
c Critical Lane Group												



















HCM Signalized Intersection Capacity Analysis
 17: Tualatin Sherwood Rd & Martinazzi Ave

4/15/2013

												
Movement	EBL	EBT	EBR	WBL	WBT	WBR	NBL	NBT	NBR	SBL	SBT	SBR
Lane Configurations		 			 						 	
Volume (vph)	55	1515	83	0	1146	0	95	312	333	194	673	90
Ideal Flow (vphpl)	1900	1900	1900	1900	1900	1900	1900	1900	1900	1900	1900	1900
Total Lost time (s)	4.5	5.5			5.5		4.5	5.5	5.5	4.5	5.5	
Lane Util. Factor	1.00	0.95			0.95		1.00	1.00	1.00	1.00	0.95	
Frbp, ped/bikes	1.00	1.00			1.00		1.00	1.00	0.98	1.00	1.00	
Flpb, ped/bikes	1.00	1.00			1.00		1.00	1.00	1.00	1.00	1.00	
Fr t	1.00	0.99			1.00		1.00	1.00	0.85	1.00	0.98	
Fl t Protected	0.95	1.00			1.00		0.95	1.00	1.00	0.95	1.00	
Satd. Flow (prot)	1719	3448			3438		1770	1863	1574	1787	3497	
Fl t Permitted	0.95	1.00			1.00		0.95	1.00	1.00	0.95	1.00	
Satd. Flow (perm)	1719	3448			3438		1770	1863	1574	1787	3497	
Peak-hour factor, PHF	0.94	0.94	0.94	0.94	0.94	0.94	0.94	0.94	0.94	0.94	0.94	0.94
Adj. Flow (vph)	59	1612	88	0	1219	0	101	332	354	206	716	96
RTOR Reduction (vph)	0	3	0	0	0	0	0	0	80	0	10	0
Lane Group Flow (vph)	59	1697	0	0	1219	0	101	332	274	206	802	0
Confl. Peds. (#/hr)			4				2		3			16
Heavy Vehicles (%)	5%	4%	0%	0%	5%	0%	2%	2%	1%	1%	1%	1%
Turn Type	Prot						Prot		Perm	Prot		
Protected Phases	5	2			6		3	8		7	4	
Permitted Phases									8			
Actuated Green, G (s)	7.2	65.2			53.0		9.9	24.1	24.1	18.7	32.9	
Effective Green, g (s)	7.7	65.7			53.5		10.4	24.6	24.6	19.2	33.4	
Actuated g/C Ratio	0.06	0.53			0.43		0.08	0.20	0.20	0.15	0.27	
Clearance Time (s)	5.0	6.0			6.0		5.0	6.0	6.0	5.0	6.0	
Vehicle Extension (s)	2.0	3.5			3.5		3.0	2.0	2.0	3.0	2.0	
Lane Grp Cap (vph)	106	1812			1471		147	367	310	274	934	
v/s Ratio Prot	0.03	c0.49			0.35		0.06	c0.18		0.12	c0.23	
v/s Ratio Perm									0.17			
v/c Ratio	0.56	0.94			0.83		0.69	0.90	0.88	0.75	0.86	
Uniform Delay, d1	57.0	27.7			31.7		55.7	49.1	48.8	50.6	43.6	
Progression Factor	1.20	0.74			1.09		1.00	1.00	1.00	1.00	1.00	
Incremental Delay, d2	2.7	8.5			4.4		12.5	24.3	23.7	11.0	7.7	
Delay (s)	70.9	29.0			38.9		68.3	73.4	72.5	61.7	51.2	
Level of Service	E	C			D		E	E	E	E	D	
Approach Delay (s)		30.4			38.9			72.3			53.3	
Approach LOS		C			D			E			D	
Intersection Summary												
HCM Average Control Delay			44.4				HCM Level of Service			D		
HCM Volume to Capacity ratio			0.89									
Actuated Cycle Length (s)			125.0				Sum of lost time (s)		11.0			
Intersection Capacity Utilization			89.5%				ICU Level of Service		E			
Analysis Period (min)			15									
c Critical Lane Group												





















HCM Signalized Intersection Capacity Analysis
18: SW Borland Rd & SW 65th Ave

4/15/2013

												
Movement	EBL	EBT	EBR	WBL	WBT	WBR	NBL	NBT	NBR	SBL	SBT	SBR
Lane Configurations												
Volume (vph)	23	23	10	240	0	244	2	334	369	433	474	10
Ideal Flow (vphpl)	1900	1900	1900	1900	1900	1900	1900	1900	1900	1900	1900	1900
Total Lost time (s)		5.6			5.3	5.6	4.8	4.8		4.8	4.8	
Lane Util. Factor		1.00			1.00	1.00	1.00	1.00		1.00	1.00	
Frbp, ped/bikes		0.99			1.00	0.90	1.00	0.98		1.00	1.00	
Flpb, ped/bikes		1.00			1.00	1.00	1.00	1.00		1.00	1.00	
Frt		0.98			1.00	0.85	1.00	0.92		1.00	1.00	
Flt Protected		0.98			0.95	1.00	0.95	1.00		0.95	1.00	
Satd. Flow (prot)		1785			1805	1456	1748	1719		1787	1893	
Flt Permitted		0.98			0.95	1.00	0.48	1.00		0.08	1.00	
Satd. Flow (perm)		1785			1805	1456	880	1719		157	1893	
Peak-hour factor, PHF	0.96	0.96	0.96	0.96	0.96	0.96	0.96	0.96	0.96	0.96	0.96	0.96
Adj. Flow (vph)	24	24	10	250	0	254	2	348	384	451	494	10
RTOR Reduction (vph)	0	6	0	0	0	240	0	25	0	0	0	0
Lane Group Flow (vph)	0	52	0	0	250	14	2	707	0	451	504	0
Confl. Peds. (#/hr)	9		2	2		9	3		4	4		3
Heavy Vehicles (%)	0%	2%	2%	0%	1%	0%	3%	0%	0%	1%	0%	0%
Turn Type	Split			Split		custom	pm+pt			pm+pt		
Protected Phases	8	8		4	4		1	6		5	2	
Permitted Phases						8	6			2		
Actuated Green, G (s)		7.6			20.0	7.6	65.3	64.3		99.6	93.3	
Effective Green, g (s)		8.1			20.5	8.1	66.3	64.8		100.1	93.8	
Actuated g/C Ratio		0.06			0.14	0.06	0.46	0.45		0.69	0.65	
Clearance Time (s)		6.1			5.8	6.1	5.3	5.3		5.3	5.3	
Vehicle Extension (s)		1.0			2.0	1.0	1.0	3.0		2.5	0.2	
Lane Grp Cap (vph)		100			256	82	413	771		453	1230	
v/s Ratio Prot		c0.03			c0.14		0.00	0.41		c0.21	0.27	
v/s Ratio Perm						0.01	0.00			c0.48		
v/c Ratio		0.52			0.98	0.17	0.00	0.92		1.00	0.41	
Uniform Delay, d1		66.3			61.7	65.0	21.1	37.3		45.6	12.1	
Progression Factor		1.00			1.00	1.00	1.00	1.00		1.00	1.00	
Incremental Delay, d2		2.3			49.0	0.4	0.0	15.5		40.9	0.1	
Delay (s)		68.5			110.8	65.3	21.1	52.8		86.5	12.2	
Level of Service		E			F	E	C	D		F	B	
Approach Delay (s)		68.5			87.9			52.7			47.2	
Approach LOS		E			F			D			D	
Intersection Summary												
HCM Average Control Delay			58.7									HCM Level of Service E
HCM Volume to Capacity ratio			0.95									
Actuated Cycle Length (s)			144.4									Sum of lost time (s) 15.7
Intersection Capacity Utilization			96.8%									ICU Level of Service F
Analysis Period (min)			15									
c Critical Lane Group												

HCM Signalized Intersection Capacity Analysis
 19: SW Sagert St & SW Boones Ferry Rd

4/15/2013

												
Movement	EBL	EBT	EBR	WBL	WBT	WBR	NBL	NBT	NBR	SBL	SBT	SBR
Lane Configurations												
Volume (vph)	42	117	13	166	122	64	16	486	218	65	571	75
Ideal Flow (vphpl)	1900	1900	1900	1900	1900	1900	1900	1900	1900	1900	1900	1900
Total Lost time (s)	3.5	3.5		3.5	3.5		3.5	4.0		3.5	4.0	
Lane Util. Factor	1.00	1.00		1.00	1.00		1.00	1.00		1.00	1.00	
Frbp, ped/bikes	1.00	1.00		1.00	0.98		1.00	0.99		1.00	1.00	
Flpb, ped/bikes	0.99	1.00		1.00	1.00		1.00	1.00		1.00	1.00	
Frt	1.00	0.98		1.00	0.95		1.00	0.95		1.00	0.98	
Flt Protected	0.95	1.00		0.95	1.00		0.95	1.00		0.95	1.00	
Satd. Flow (prot)	1782	1830		1781	1739		1769	1789		1804	1860	
Flt Permitted	0.64	1.00		0.42	1.00		0.25	1.00		0.17	1.00	
Satd. Flow (perm)	1191	1830		785	1739		468	1789		319	1860	
Peak-hour factor, PHF	0.95	0.95	0.95	0.95	0.95	0.95	0.95	0.95	0.95	0.95	0.95	0.95
Adj. Flow (vph)	44	123	14	175	128	67	17	512	229	68	601	79
RTOR Reduction (vph)	0	4	0	0	16	0	0	11	0	0	3	0
Lane Group Flow (vph)	44	133	0	175	179	0	17	730	0	68	677	0
Confl. Peds. (#/hr)	15		7	7		15	7		8	8		7
Heavy Vehicles (%)	0%	2%	1%	1%	3%	0%	2%	0%	1%	0%	0%	0%
Turn Type	pm+pt		pm+pt				pm+pt			pm+pt		
Protected Phases	7	4		3	8		5	2		1	6	
Permitted Phases	4			8			2			6		
Actuated Green, G (s)	15.3	12.4		25.7	18.8		47.1	45.6		51.5	47.8	
Effective Green, g (s)	16.3	12.9		26.2	19.3		48.1	46.1		52.5	48.3	
Actuated g/C Ratio	0.19	0.15		0.30	0.22		0.55	0.53		0.60	0.55	
Clearance Time (s)	4.0	4.0		4.0	4.0		4.0	4.5		4.0	4.5	
Vehicle Extension (s)	2.2	2.2		2.2	2.2		2.2	5.0		2.2	5.0	
Lane Grp Cap (vph)	245	270		347	384		287	943		263	1027	
v/s Ratio Prot	0.01	0.07		c0.06	0.10		0.00	c0.41		c0.01	0.36	
v/s Ratio Perm	0.03			c0.09			0.03			0.14		
v/c Ratio	0.18	0.49		0.50	0.47		0.06	0.77		0.26	0.66	
Uniform Delay, d1	29.7	34.3		24.1	29.6		10.8	16.5		11.9	13.8	
Progression Factor	1.00	1.00		1.00	1.00		1.00	1.00		1.00	1.00	
Incremental Delay, d2	0.2	0.7		0.6	0.5		0.0	4.7		0.3	2.1	
Delay (s)	29.9	35.0		24.7	30.1		10.8	21.2		12.2	15.9	
Level of Service	C	D		C	C		B	C		B	B	
Approach Delay (s)		33.8			27.5			21.0			15.5	
Approach LOS		C			C			C			B	
Intersection Summary												
HCM Average Control Delay			21.3			HCM Level of Service				C		
HCM Volume to Capacity ratio			0.68									
Actuated Cycle Length (s)			87.5			Sum of lost time (s)			14.5			
Intersection Capacity Utilization			74.8%			ICU Level of Service				D		
Analysis Period (min)			15									
c Critical Lane Group												

Phone:
E-Mail:

Fax:

ALL-WAY STOP CONTROL (AWSC) ANALYSIS

Analyst:
Agency/Co.:
Date Performed: 4/16/2013
Analysis Time Period: Weekday PM
Intersection: Sagert/Martinazzi
Jurisdiction:
Units: U. S. Customary
Analysis Year: Total
Project ID:
East/West Street: Sagert
North/South Street: Martinazzi

Worksheet 2 - Volume Adjustments and Site Characteristics

	Eastbound			Westbound			Northbound			Southbound		
	L	T	R	L	T	R	L	T	R	L	T	R
Volume	127	233	12	90	195	164	2		76	207	306	0
% Thrus Left Lane												

	Eastbound		Westbound		Northbound		Southbound	
	L1	L2	L1	L2	L1	L2	L1	L2
Configuration	L	TR	L	TR	L	TR	L	TR
PHF	0.90	0.90	0.90	0.90	0.90	0.90	0.90	0.90
Flow Rate	141	271	100	398	2	284	230	340
% Heavy Veh	1	1	1	1	1	1	1	1
No. Lanes		2		2		2		2
Opposing-Lanes		2		2		2		2
Conflicting-lanes		2		2		2		2
Geometry group		5		5		5		5
Duration, T	0.25 hrs.							

Worksheet 3 - Saturation Headway Adjustment Worksheet

	Eastbound		Westbound		Northbound		Southbound	
	L1	L2	L1	L2	L1	L2	L1	L2
Flow Rates:								
Total in Lane	141	271	100	398	2	284	230	340
Left-Turn	141	0	100	0	2	0	230	0
Right-Turn	0	13	0	182	0	84	0	0
Prop. Left-Turns	1.0	0.0	1.0	0.0	1.0	0.0	1.0	0.0
Prop. Right-Turns	0.0	0.0	0.0	0.5	0.0	0.3	0.0	0.0
Prop. Heavy Vehicle	0.0	0.0	0.0	0.0	0.0	0.0	0.0	0.0
Geometry Group		5		5		5		5
Adjustments Exhibit 17-33:								
hLT-adj		0.5		0.5		0.5		0.5

hRT-adj	-0.7		-0.7		-0.7		-0.7	
hHV-adj	1.7		1.7		1.7		1.7	
hadj, computed	0.5	-0.0	0.5	-0.3	0.5	-0.2	0.5	0.0

Worksheet 4 - Departure Headway and Service Time

	Eastbound		Westbound		Northbound		Southbound	
	L1	L2	L1	L2	L1	L2	L1	L2
Flow rate	141	271	100	398	2	284	230	340
hd, initial value	3.20	3.20	3.20	3.20	3.20	3.20	3.20	3.20
x, initial	0.13	0.24	0.09	0.35	0.00	0.25	0.20	0.30
hd, final value	8.96	8.42	8.76	7.94	9.19	8.48	8.72	8.22
x, final value	0.35	0.63	0.24	0.88	0.01	0.67	0.56	0.78
Move-up time, m		2.3		2.3		2.3		2.3
Service Time	6.7	6.1	6.5	5.6	6.9	6.2	6.4	5.9

Worksheet 5 - Capacity and Level of Service

	Eastbound		Westbound		Northbound		Southbound	
	L1	L2	L1	L2	L1	L2	L1	L2
Flow Rate	141	271	100	398	2	284	230	340
Service Time	6.7	6.1	6.5	5.6	6.9	6.2	6.4	5.9
Utilization, x	0.35	0.63	0.24	0.88	0.01	0.67	0.56	0.78
Dep. headway, hd	8.96	8.42	8.76	7.94	9.19	8.48	8.72	8.22
Capacity	391	418	350	450	252	413	407	433
Delay	16.42	24.61	14.25	45.54	11.93	26.70	21.85	34.14
LOS	C	C	B	E	B	D	C	D
Approach:								
Delay		21.81		39.26		26.59		29.18
LOS		C		E		D		D
Intersection Delay	29.88							

Phone:
E-Mail:

Fax:

ALL-WAY STOP CONTROL (AWSC) ANALYSIS

Analyst:
Agency/Co.:
Date Performed: 4/16/2013
Analysis Time Period: Weekday PM
Intersection: Sagert/65th
Jurisdiction:
Units: U. S. Customary
Analysis Year: Total
Project ID:
East/West Street: Sagert
North/South Street: 65th

Worksheet 2 - Volume Adjustments and Site Characteristics

	Eastbound			Westbound			Northbound			Southbound		
	L	T	R	L	T	R	L	T	R	L	T	R
Volume	401	2	135	2	7	6	58		3	3	340	386
% Thrus Left Lane												

	Eastbound		Westbound		Northbound		Southbound	
	L1	L2	L1	L2	L1	L2	L1	L2
Configuration	L	TR	L	TR	L	TR	L	TR
PHF	0.90	0.90	0.90	0.90	0.90	0.90	0.90	0.90
Flow Rate	445	152	2	13	64	323	3	805
% Heavy Veh	1	1	0	0	1	2	1	2
No. Lanes		2		2		2		2
Opposing-Lanes		2		2		2		2
Conflicting-lanes		2		2		2		2
Geometry group		5		5		5		5
Duration, T	0.25 hrs.							

Worksheet 3 - Saturation Headway Adjustment Worksheet

	Eastbound		Westbound		Northbound		Southbound	
	L1	L2	L1	L2	L1	L2	L1	L2
Flow Rates:								
Total in Lane	445	152	2	13	64	323	3	805
Left-Turn	445	0	2	0	64	0	3	0
Right-Turn	0	150	0	6	0	3	0	428
Prop. Left-Turns	1.0	0.0	1.0	0.0	1.0	0.0	1.0	0.0
Prop. Right-Turns	0.0	1.0	0.0	0.5	0.0	0.0	0.0	0.5
Prop. Heavy Vehicle	0.0	0.0	0.0	0.0	0.0	0.0	0.0	0.0
Geometry Group		5		5		5		5
Adjustments Exhibit 17-33:								
hLT-adj		0.5		0.5		0.5		0.5

hRT-adj	-0.7	-0.7	-0.7	-0.7
hHV-adj	1.7	1.7	1.7	1.7
hadj, computed	0.5	-0.7	0.5	-0.3

Worksheet 4 - Departure Headway and Service Time

	Eastbound		Westbound		Northbound		Southbound	
	L1	L2	L1	L2	L1	L2	L1	L2
Flow rate	445	152	2	13	64	323	3	805
hd, initial value	3.20	3.20	3.20	3.20	3.20	3.20	3.20	3.20
x, initial	0.40	0.14	0.00	0.01	0.06	0.29	0.00	0.72
hd, final value	7.73	6.54	9.23	8.40	8.00	7.51	7.77	6.92
x, final value	0.96	0.28	0.01	0.03	0.14	0.67	0.01	1.55
Move-up time, m		2.3		2.3		2.3		2.3
Service Time	5.4	4.2	6.9	6.1	5.7	5.2	5.5	4.6

Worksheet 5 - Capacity and Level of Service

	Eastbound		Westbound		Northbound		Southbound	
	L1	L2	L1	L2	L1	L2	L1	L2
Flow Rate	445	152	2	13	64	323	3	805
Service Time	5.4	4.2	6.9	6.1	5.7	5.2	5.5	4.6
Utilization, x	0.96	0.28	0.01	0.03	0.14	0.67	0.01	1.55
Dep. headway, hd	7.73	6.54	9.23	8.40	8.00	7.51	7.77	6.92
Capacity	466	402	252	263	314	475	253	805
Delay	58.85	11.71	11.98	11.37	12.02	24.33	10.52	273.87
LOS	F	B	B	B	B	C	B	F
Approach:								
Delay		46.85		11.45		22.29		272.89
LOS		E		B		C		F
Intersection Delay	142.37							

HCM Unsignalized Intersection Capacity Analysis
 22: SW Boones Fe &

4/15/2013



Movement	EBT	EBR	WBL	WBT	NWL	NWR
Lane Configurations	↶			↶↶		↶
Volume (veh/h)	1051	10	0	1384	0	35
Sign Control	Free			Free	Stop	
Grade	0%			0%	0%	
Peak Hour Factor	0.92	0.92	0.92	0.92	0.92	0.92
Hourly flow rate (vph)	1142	11	0	1504	0	38
Pedestrians						
Lane Width (ft)						
Walking Speed (ft/s)						
Percent Blockage						
Right turn flare (veh)						
Median type	TWLTL		None			
Median storage (veh)	2					
Upstream signal (ft)	252					
pX, platoon unblocked			0.63		0.63	0.63
vC, conflicting volume			1153		1900	1148
vC1, stage 1 conf vol					1148	
vC2, stage 2 conf vol					752	
vCu, unblocked vol			949		2136	940
tC, single (s)			4.1		6.8	6.9
tC, 2 stage (s)					5.8	
tF (s)			2.2		3.5	3.3
p0 queue free %			100		100	77
cM capacity (veh/h)			453		185	167

Direction, Lane #	EB 1	WB 1	WB 2	NW 1
Volume Total	1153	752	752	38
Volume Left	0	0	0	0
Volume Right	11	0	0	38
cSH	1700	1700	1700	167
Volume to Capacity	0.68	0.44	0.44	0.23
Queue Length 95th (ft)	0	0	0	21
Control Delay (s)	0.0	0.0	0.0	32.9
Lane LOS				D
Approach Delay (s)	0.0	0.0		32.9
Approach LOS				D

Intersection Summary			
Average Delay		0.5	
Intersection Capacity Utilization		65.9%	ICU Level of Service C
Analysis Period (min)		15	

HCM Signalized Intersection Capacity Analysis

3: SW Boones Ferry Rd & SW Martinazzi Ave

4/17/2013





















	→	↘	↙	←	↖	↗
Movement	EBT	EBR	WBL	WBT	NBL	NBR
Lane Configurations	↑	↗	↘	↑	↘	↗
Volume (vph)	435	127	318	429	201	309
Ideal Flow (vphpl)	1900	1900	1900	1900	1900	1900
Total Lost time (s)	4.5	4.5	4.5	4.5	4.5	4.5
Lane Util. Factor	1.00	1.00	1.00	1.00	1.00	1.00
Frpb, ped/bikes	1.00	1.00	1.00	1.00	1.00	0.99
Flpb, ped/bikes	1.00	1.00	1.00	1.00	1.00	1.00
Fr t	1.00	0.85	1.00	1.00	1.00	0.85
Fl t Protected	1.00	1.00	0.95	1.00	0.95	1.00
Satd. Flow (prot)	1863	1599	1787	1845	1770	1582
Fl t Permitted	1.00	1.00	0.95	1.00	0.95	1.00
Satd. Flow (perm)	1863	1599	1787	1845	1770	1582
Peak-hour factor, PHF	0.95	0.95	0.95	0.95	0.95	0.95
Adj. Flow (vph)	458	134	335	452	212	325
RTOR Reduction (vph)	0	89	0	0	0	86
Lane Group Flow (vph)	458	45	335	452	212	239
Confl. Peds. (#/hr)		11	11		1	3
Confl. Bikes (#/hr)	4		2	10	1	
Heavy Vehicles (%)	2%	1%	1%	3%	2%	1%
Turn Type		Prot	Prot			pm+ov
Protected Phases	2	2	1	6	8	1
Permitted Phases					8	8
Actuated Green, G (s)	20.0	20.0	16.8	41.8	12.6	29.4
Effective Green, g (s)	20.5	20.5	17.3	42.3	13.1	30.4
Actuated g/C Ratio	0.32	0.32	0.27	0.66	0.20	0.47
Clearance Time (s)	5.0	5.0	5.0	5.0	5.0	5.0
Vehicle Extension (s)	3.0	3.0	3.0	3.0	3.0	3.0
Lane Grp Cap (vph)	593	509	480	1212	360	857
v/s Ratio Prot	c0.25	0.03	c0.19	0.25	c0.12	0.07
v/s Ratio Perm						0.08
v/c Ratio	0.77	0.09	0.70	0.37	0.59	0.28
Uniform Delay, d1	19.8	15.4	21.2	5.0	23.2	10.3
Progression Factor	1.00	1.00	1.00	1.00	1.00	1.00
Incremental Delay, d2	6.2	0.1	4.4	0.2	2.5	0.2
Delay (s)	26.0	15.5	25.6	5.2	25.7	10.5
Level of Service	C	B	C	A	C	B
Approach Delay (s)	23.6			13.9	16.5	
Approach LOS	C			B	B	
Intersection Summary						
HCM Average Control Delay			17.6		HCM Level of Service	B
HCM Volume to Capacity ratio			0.70			
Actuated Cycle Length (s)			64.4		Sum of lost time (s)	13.5
Intersection Capacity Utilization			63.5%		ICU Level of Service	B
Analysis Period (min)			15			

c Critical Lane Group

HCM Signalized Intersection Capacity Analysis

5: Seneca St & Martinazzi Ave

4/17/2013





















													
Movement	EBL	EBT	EBR	WBL	WBT	WBR	NBL	NBT	NBR	SBL	SBT	SBR	
Lane Configurations													
Volume (vph)	37	0	45	65	0	136	81	337	84	185	212	44	
Ideal Flow (vphpl)	1900	1900	1900	1900	1900	1900	1900	1900	1900	1900	1900	1900	
Total Lost time (s)	1.5	1.5			1.5	1.5	1.5	1.5		1.5	1.5		
Lane Util. Factor	1.00	1.00			1.00	1.00	1.00	1.00		1.00	1.00		
Frbp, ped/bikes	1.00	0.99			1.00	1.00	1.00	1.00		1.00	1.00		
Flpb, ped/bikes	0.99	1.00			1.00	1.00	1.00	1.00		1.00	1.00		
Frt	1.00	0.85			1.00	0.85	1.00	0.97		1.00	0.97		
Flt Protected	0.95	1.00			0.95	1.00	0.95	1.00		0.95	1.00		
Satd. Flow (prot)	1790	1592			1770	1583	1804	1822		1770	1815		
Flt Permitted	0.75	1.00			0.75	1.00	0.59	1.00		0.34	1.00		
Satd. Flow (perm)	1422	1592			1406	1583	1115	1822		638	1815		
Peak-hour factor, PHF	0.91	0.92	0.91	0.92	0.92	0.92	0.91	0.91	0.92	0.92	0.91	0.91	
Adj. Flow (vph)	41	0	49	71	0	148	89	370	91	201	233	48	
RTOR Reduction (vph)	0	40	0	0	0	121	0	11	0	0	10	0	
Lane Group Flow (vph)	41	9	0	0	71	27	89	450	0	201	271	0	
Confl. Peds. (#/hr)	10		4				1					1	
Confl. Bikes (#/hr)								2			3		
Heavy Vehicles (%)	0%	2%	0%	2%	2%	2%	0%	1%	2%	2%	2%	0%	
Turn Type	Perm			Perm		Perm	pm+pt			pm+pt			
Protected Phases		4			8		5	2		1	6		
Permitted Phases	4			8		8	2			6			
Actuated Green, G (s)	4.8	4.8			4.8	4.8	17.1	14.2		20.1	15.7		
Effective Green, g (s)	5.3	5.3			5.3	5.3	18.1	14.7		21.1	16.2		
Actuated g/C Ratio	0.18	0.18			0.18	0.18	0.62	0.50		0.72	0.55		
Clearance Time (s)	2.0	2.0			2.0	2.0	2.0	2.0		2.0	2.0		
Vehicle Extension (s)	3.0	3.0			3.0	3.0	3.0	3.0		3.0	3.0		
Lane Grp Cap (vph)	256	287			253	285	766	911		647	1000		
v/s Ratio Prot		0.01					0.01	c0.25		c0.05	0.15		
v/s Ratio Perm	0.03			c0.05	0.02	0.06				0.17			
v/c Ratio	0.16	0.03		0.28	0.09	0.12	0.49			0.31	0.27		
Uniform Delay, d1	10.2	9.9		10.4	10.0	2.3	4.9			1.9	3.5		
Progression Factor	1.00	1.00		1.00	1.00	1.00	1.00			1.00	1.00		
Incremental Delay, d2	0.3	0.0		0.6	0.1	0.1	0.4			0.3	0.1		
Delay (s)	10.5	10.0		11.0	10.2	2.4	5.3			2.2	3.6		
Level of Service	B	A		B	B	A	A			A	A		
Approach Delay (s)		10.2		10.5			4.8				3.0		
Approach LOS		B		B			A				A		
Intersection Summary													
HCM Average Control Delay			5.5									HCM Level of Service	A
HCM Volume to Capacity ratio			0.37										
Actuated Cycle Length (s)			29.4									Sum of lost time (s)	4.5
Intersection Capacity Utilization			53.4%									ICU Level of Service	A
Analysis Period (min)			15										

c Critical Lane Group

HCM Signalized Intersection Capacity Analysis

8: Nyberg St & Martinazzi Ave

4/17/2013

												
Movement	EBL	EBT	EBR	WBL	WBT	WBR	NBL	NBT	NBR	SBL	SBT	SBR
Lane Configurations												
Volume (vph)	16	1	63	260	37	237	23	240	36	0	314	8
Ideal Flow (vphpl)	1900	1900	1900	1900	1900	1900	1900	1900	1900	1900	1900	1900
Total Lost time (s)	5.5	5.5		5.5	5.5	5.5	5.5	5.5			5.5	
Lane Util. Factor	1.00	1.00		0.95	0.95	1.00	1.00	1.00			0.95	
Frpb, ped/bikes	1.00	1.00		1.00	1.00	0.97	1.00	0.99			1.00	
Flpb, ped/bikes	1.00	1.00		1.00	1.00	1.00	1.00	1.00			1.00	
Frt	1.00	0.85		1.00	1.00	0.85	1.00	0.98			1.00	
Flt Protected	0.95	1.00		0.95	0.96	1.00	0.95	1.00			1.00	
Satd. Flow (prot)	1805	1603		1698	1727	1543	1683	1837			3559	
Flt Permitted	0.95	1.00		0.95	0.96	1.00	0.54	1.00			1.00	
Satd. Flow (perm)	1805	1603		1698	1727	1543	957	1837			3559	
Peak-hour factor, PHF	0.91	0.91	0.91	0.91	0.91	0.91	0.91	0.91	0.91	0.91	0.91	0.91
Adj. Flow (vph)	18	1	69	286	41	260	25	264	40	0	345	9
RTOR Reduction (vph)	0	63	0	0	0	202	0	8	0	0	3	0
Lane Group Flow (vph)	18	7	0	163	164	58	25	296	0	0	351	0
Confl. Peds. (#/hr)	2					2	3		16	16		3
Confl. Bikes (#/hr)						2						3
Heavy Vehicles (%)	0%	0%	1%	1%	0%	2%	7%	1%	0%	0%	1%	0%
Turn Type	Split			Split			Perm	Perm				
Protected Phases	8	8		4	4			6			2	
Permitted Phases						4	6					
Actuated Green, G (s)	3.1	3.1		9.1	9.1	9.1	12.5	12.5			12.5	
Effective Green, g (s)	3.6	3.6		9.6	9.6	9.6	13.0	13.0			13.0	
Actuated g/C Ratio	0.08	0.08		0.22	0.22	0.22	0.30	0.30			0.30	
Clearance Time (s)	6.0	6.0		6.0	6.0	6.0	6.0	6.0			6.0	
Vehicle Extension (s)	2.5	2.5		2.5	2.5	2.5	5.0	5.0			5.0	
Lane Grp Cap (vph)	152	135		382	388	347	291	559			1084	
v/s Ratio Prot	c0.01	0.00		c0.10	0.09			c0.16			0.10	
v/s Ratio Perm						0.04	0.03					
v/c Ratio	0.12	0.05		0.43	0.42	0.17	0.09	0.53			0.32	
Uniform Delay, d1	18.1	18.0		14.2	14.2	13.3	10.6	12.3			11.5	
Progression Factor	1.00	1.00		1.00	1.00	1.00	1.00	1.00			1.00	
Incremental Delay, d2	0.3	0.1		0.6	0.5	0.2	0.3	1.8			0.4	
Delay (s)	18.3	18.1		14.8	14.7	13.5	10.9	14.1			11.8	
Level of Service	B	B		B	B	B	B	B			B	
Approach Delay (s)		18.1			14.2			13.8			11.8	
Approach LOS		B			B			B			B	
Intersection Summary												
HCM Average Control Delay			13.7								HCM Level of Service	B
HCM Volume to Capacity ratio			0.44									
Actuated Cycle Length (s)			42.7								Sum of lost time (s)	16.5
Intersection Capacity Utilization			48.7%								ICU Level of Service	A
Analysis Period (min)			15									

c Critical Lane Group

HCM Unsignalized Intersection Capacity Analysis

9: Nyberg St & Site Entrance 3



























4/17/2013



Movement	EBL	EBT	WBT	WBR	SBL	SBR
Lane Configurations	↰		↱↰			↰
Volume (veh/h)	37	0	466	60	0	67
Sign Control		Free	Free		Stop	
Grade		0%	0%		0%	
Peak Hour Factor	0.88	0.88	0.88	0.88	0.88	0.88
Hourly flow rate (vph)	42	0	530	68	0	76
Pedestrians					4	
Lane Width (ft)					12.0	
Walking Speed (ft/s)					4.0	
Percent Blockage					0	
Right turn flare (veh)						
Median type		None	None			
Median storage (veh)						
Upstream signal (ft)		232				
pX, platoon unblocked						
vC, conflicting volume	602				652	303
vC1, stage 1 conf vol						
vC2, stage 2 conf vol						
vCu, unblocked vol	602				652	303
tC, single (s)	4.1				6.8	6.9
tC, 2 stage (s)						
tF (s)	2.2				3.5	3.3
p0 queue free %	96				100	89
cM capacity (veh/h)	982				387	697
Direction, Lane #	EB 1	WB 1	WB 2	SB 1		
Volume Total	42	353	245	76		
Volume Left	42	0	0	0		
Volume Right	0	0	68	76		
cSH	982	1700	1700	697		
Volume to Capacity	0.04	0.21	0.14	0.11		
Queue Length 95th (ft)	3	0	0	10		
Control Delay (s)	8.8	0.0	0.0	10.8		
Lane LOS	A			B		
Approach Delay (s)	8.8	0.0		10.8		
Approach LOS				B		
Intersection Summary						
Average Delay			1.7			
Intersection Capacity Utilization			25.7%		ICU Level of Service	A
Analysis Period (min)			15			

HCM Signalized Intersection Capacity Analysis
 10: Tualatin Sherwood Rd & Site Entrance 4

4/17/2013

												
Movement	EBL	EBT	EBR	WBL	WBT	WBR	NBL	NBT	NBR	SBL	SBT	SBR
Lane Configurations		  		 	  					 		
Volume (vph)	180	1335	59	257	1458	361	57	25	248	373	40	190
Ideal Flow (vphpl)	1900	1900	1900	1900	1900	1900	1900	1900	1900	1900	1900	1900
Total Lost time (s)	4.5	6.0		4.5	6.0	6.0		5.0	4.5	5.0	5.0	
Lane Util. Factor	1.00	*0.75		0.97	0.91	1.00		1.00	1.00	0.97	1.00	
Frbp, ped/bikes	1.00	1.00		1.00	1.00	0.97		1.00	1.00	1.00	0.98	
Flpb, ped/bikes	1.00	1.00		1.00	1.00	1.00		1.00	1.00	1.00	1.00	
Frt	1.00	0.99		1.00	1.00	0.85		1.00	0.85	1.00	0.88	
Flt Protected	0.95	1.00		0.95	1.00	1.00		0.97	1.00	0.95	1.00	
Satd. Flow (prot)	1805	4091		3502	4988	1565		1799	1599	3467	1634	
Flt Permitted	0.95	1.00		0.95	1.00	1.00		0.97	1.00	0.95	1.00	
Satd. Flow (perm)	1805	4091		3502	4988	1565		1799	1599	3467	1634	
Peak-hour factor, PHF	0.98	0.98	0.98	0.98	0.98	0.98	0.98	0.98	0.98	0.98	0.98	0.98
Adj. Flow (vph)	184	1362	60	262	1488	368	58	26	253	381	41	194
RTOR Reduction (vph)	0	3	0	0	0	201	0	0	0	0	164	0
Lane Group Flow (vph)	184	1419	0	262	1488	167	0	84	253	381	71	0
Confl. Peds. (#/hr)						4						9
Confl. Bikes (#/hr)					1			1		1		
Heavy Vehicles (%)	0%	4%	0%	0%	4%	0%	3%	0%	1%	1%	0%	0%
Turn Type	Prot			Prot		Perm	Split		pt+ov	Split		
Protected Phases	5	2		1	6		8	8	18	4	4	
Permitted Phases						6						
Actuated Green, G (s)	14.8	49.6		17.0	51.8	51.8		8.5	25.5	17.4	17.4	
Effective Green, g (s)	15.3	50.1		17.5	52.3	52.3		9.0	26.5	17.9	17.9	
Actuated g/C Ratio	0.13	0.44		0.15	0.45	0.45		0.08	0.23	0.16	0.16	
Clearance Time (s)	5.0	6.5		5.0	6.5	6.5		5.5		5.5	5.5	
Vehicle Extension (s)	2.5	4.0		2.5	4.0	4.0		2.5		2.5	2.5	
Lane Grp Cap (vph)	240	1782		533	2268	712		141	368	540	254	
v/s Ratio Prot	0.10	c0.35		0.07	c0.30			0.05	c0.16	c0.11	0.04	
v/s Ratio Perm						0.11						
v/c Ratio	0.77	0.80		0.49	0.66	0.24		0.60	0.69	0.71	0.28	
Uniform Delay, d1	48.1	28.0		44.7	24.4	19.1		51.2	40.5	46.1	42.9	
Progression Factor	0.90	1.35		0.96	0.90	1.07		1.00	1.00	1.00	1.00	
Incremental Delay, d2	10.1	2.9		0.3	1.0	0.5		5.5	4.8	3.9	0.4	
Delay (s)	53.6	40.7		43.3	23.0	20.9		56.8	45.3	49.9	43.3	
Level of Service	D	D		D	C	C		E	D	D	D	
Approach Delay (s)		42.2			25.2			48.2			47.4	
Approach LOS		D			C			D			D	

Intersection Summary













HCM Average Control Delay	35.6	HCM Level of Service	D
HCM Volume to Capacity ratio	0.71		
Actuated Cycle Length (s)	115.0	Sum of lost time (s)	15.5
Intersection Capacity Utilization	77.3%	ICU Level of Service	D
Analysis Period (min)	15		

c Critical Lane Group

HCM Signalized Intersection Capacity Analysis

12: Tualatin Sherwood Rd & I-5 SB Ramps













4/17/2013

													
Movement	EBL	EBT	EBR	WBL	WBT	WBR	NBL	NBT	NBR	SBL	SBT	SBR	
Lane Configurations		↑↑↑	↑	↑	↑↑					↑	↑	↑↑	
Volume (vph)	0	1484	480	193	1150	0	0	0	0	620	3	965	
Ideal Flow (vphpl)	1900	1900	1900	1900	1900	1900	1900	1900	1900	1900	1900	1900	
Total Lost time (s)		5.5	5.5	5.5	5.5					5.5	5.5	5.5	
Lane Util. Factor		*0.75	1.00	1.00	0.95					0.95	0.95	0.88	
Frbp, ped/bikes		1.00	1.00	1.00	1.00					1.00	1.00	1.00	
Flpb, ped/bikes		1.00	1.00	1.00	1.00					1.00	1.00	1.00	
Frt		1.00	0.85	1.00	1.00					1.00	1.00	0.85	
Flt Protected		1.00	1.00	0.95	1.00					0.95	0.95	1.00	
Satd. Flow (prot)		4150	1568	1787	3471					1681	1683	2760	
Flt Permitted		1.00	1.00	0.95	1.00					0.95	0.95	1.00	
Satd. Flow (perm)		4150	1568	1787	3471					1681	1683	2760	
Peak-hour factor, PHF	0.99	0.99	0.99	0.99	0.99	0.99	0.99	0.99	0.99	0.99	0.99	0.99	
Adj. Flow (vph)	0	1499	485	195	1162	0	0	0	0	626	3	975	
RTOR Reduction (vph)	0	0	242	0	0	0	0	0	0	0	0	40	
Lane Group Flow (vph)	0	1499	243	195	1162	0	0	0	0	313	316	935	
Confl. Bikes (#/hr)		1			2								
Heavy Vehicles (%)	0%	3%	3%	1%	4%	0%	0%	0%	0%	2%	20%	3%	
Turn Type			Perm	Prot						Split		custom	
Protected Phases		2		1	6					4	4	4.5	
Permitted Phases			2										
Actuated Green, G (s)		49.4	49.4	17.0	55.4					30.6	30.6	47.6	
Effective Green, g (s)		49.9	49.9	17.5	55.9					31.1	31.1	44.6	
Actuated g/C Ratio		0.43	0.43	0.15	0.49					0.27	0.27	0.39	
Clearance Time (s)		6.0	6.0	6.0	6.0					6.0	6.0		
Vehicle Extension (s)		6.1	6.1	2.3	6.1					2.3	2.3		
Lane Grp Cap (vph)		1801	680	272	1687					455	455	1070	
v/s Ratio Prot		c0.36		c0.11	0.33					0.19	0.19	c0.34	
v/s Ratio Perm			0.16										
v/c Ratio		0.83	0.36	0.72	0.69					0.69	0.69	0.87	
Uniform Delay, d1		28.8	21.8	46.4	22.8					37.6	37.7	32.6	
Progression Factor		0.60	0.38	0.88	0.62					1.00	1.00	1.00	
Incremental Delay, d2		3.3	1.0	7.3	2.2					3.7	4.0	7.9	
Delay (s)		20.5	9.4	48.1	16.3					41.3	41.7	40.5	
Level of Service		C	A	D	B					D	D	D	
Approach Delay (s)		17.8			20.9			0.0			40.9		
Approach LOS		B			C			A			D		
Intersection Summary													
HCM Average Control Delay			26.1			HCM Level of Service				C			
HCM Volume to Capacity ratio			0.89										
Actuated Cycle Length (s)			115.0			Sum of lost time (s)				22.0			
Intersection Capacity Utilization			74.7%			ICU Level of Service				D			
Analysis Period (min)			15										
c Critical Lane Group													

HCM Signalized Intersection Capacity Analysis

13: Tualatin Sherwood Rd & I-5 NB Ramps

4/17/2013





















												
Movement	EBL	EBT	EBR	WBL	WBT	WBR	NBL	NBT	NBR	SBL	SBT	SBR
Lane Configurations		↑↑	↑↑		↑↑	↑	↑	↑	↑			
Volume (vph)	0	1110	998	0	668	666	672	0	219	0	0	0
Ideal Flow (vphpl)	1900	1900	1900	1900	1900	1900	1900	1900	1900	1900	1900	1900
Total Lost time (s)		5.5	5.5		6.0	6.0	5.5	5.5	5.5			
Lane Util. Factor		0.95	0.88		0.95	1.00	0.95	0.95	1.00			
Frbp, ped/bikes		1.00	0.98		1.00	1.00	1.00	1.00	0.98			
Flpb, ped/bikes		1.00	1.00		1.00	1.00	1.00	1.00	1.00			
Frt		1.00	0.85		1.00	0.85	1.00	1.00	0.85			
Flt Protected		1.00	1.00		1.00	1.00	0.95	0.95	1.00			
Satd. Flow (prot)		3574	2694		3574	1583	1618	1618	1559			
Flt Permitted		1.00	1.00		1.00	1.00	0.95	0.95	1.00			
Satd. Flow (perm)		3574	2694		3574	1583	1618	1618	1559			
Peak-hour factor, PHF	0.95	0.95	0.95	0.95	0.95	0.95	0.95	0.95	0.95	0.95	0.95	0.95
Adj. Flow (vph)	0	1168	1051	0	703	701	707	0	231	0	0	0
RTOR Reduction (vph)	0	0	388	0	0	262	0	0	28	0	0	0
Lane Group Flow (vph)	0	1168	663	0	703	439	353	354	203	0	0	0
Confl. Peds. (#/hr)			1	1			1		2	2		1
Confl. Bikes (#/hr)		1			5					1		
Heavy Vehicles (%)	0%	1%	3%	0%	1%	2%	6%	20%	2%	0%	0%	0%
Turn Type			Perm			Perm	Split		Perm			
Protected Phases		2			6		8	8				
Permitted Phases			2			6			8			
Actuated Green, G (s)		72.0	72.0		71.5	71.5	31.0	31.0	31.0			
Effective Green, g (s)		72.5	72.5		72.0	72.0	31.5	31.5	31.5			
Actuated g/C Ratio		0.63	0.63		0.63	0.63	0.27	0.27	0.27			
Clearance Time (s)		6.0	6.0		6.5	6.5	6.0	6.0	6.0			
Vehicle Extension (s)		6.1	6.1		4.2	4.2	2.3	2.3	2.3			
Lane Grp Cap (vph)		2253	1698		2238	991	443	443	427			
v/s Ratio Prot		c0.33			0.20		0.22	c0.22				
v/s Ratio Perm			0.25			0.28			0.13			
v/c Ratio		0.52	0.39		0.31	0.44	0.80	0.80	0.47			
Uniform Delay, d1		11.7	10.4		10.0	11.1	38.8	38.8	34.8			
Progression Factor		1.39	3.10		1.00	1.00	1.00	1.00	1.00			
Incremental Delay, d2		0.6	0.4		0.4	1.4	9.2	9.3	0.5			
Delay (s)		16.7	32.8		10.4	12.6	48.0	48.1	35.3			
Level of Service		B	C		B	B	D	D	D			
Approach Delay (s)		24.3			11.5			44.9			0.0	
Approach LOS		C			B			D			A	
Intersection Summary												
HCM Average Control Delay			24.6									C
HCM Volume to Capacity ratio			0.60									
Actuated Cycle Length (s)			115.0								11.0	
Intersection Capacity Utilization			69.4%									C
Analysis Period (min)			15									

c Critical Lane Group

HCM Signalized Intersection Capacity Analysis

14: Tualatin Sherwood Rd & Nyberg Woods

4/17/2013

												
Movement	EBL	EBT	EBR	WBL	WBT	WBR	NBL	NBT	NBR	SBL	SBT	SBR
Lane Configurations												
Volume (vph)	524	593	57	15	732	101	103	11	12	101	11	322
Ideal Flow (vphpl)	1900	1900	1900	1900	1900	1900	1900	1900	1900	1900	1900	1900
Total Lost time (s)	5.5	5.5		5.5	5.5			5.5	5.5		5.5	5.5
Lane Util. Factor	0.97	0.95		1.00	0.95			1.00	1.00		1.00	1.00
Frbp, ped/bikes	1.00	1.00		1.00	1.00			1.00	0.99		1.00	0.99
Flpb, ped/bikes	1.00	1.00		1.00	1.00			1.00	1.00		1.00	1.00
Frt	1.00	0.99		1.00	0.98			1.00	0.85		1.00	0.85
Flt Protected	0.95	1.00		0.95	1.00			0.96	1.00		0.96	1.00
Satd. Flow (prot)	3502	3486		1805	3505			1768	1593		1799	1594
Flt Permitted	0.95	1.00		0.95	1.00			0.66	1.00		0.66	1.00
Satd. Flow (perm)	3502	3486		1805	3505			1229	1593		1248	1594
Peak-hour factor, PHF	0.96	0.96	0.96	0.96	0.96	0.96	0.96	0.96	0.96	0.96	0.96	0.96
Adj. Flow (vph)	546	618	59	16	762	105	107	11	12	105	11	335
RTOR Reduction (vph)	0	5	0	0	9	0	0	0	10	0	0	279
Lane Group Flow (vph)	546	672	0	16	858	0	0	118	2	0	116	56
Confl. Peds. (#/hr)	8		2	2		8	1		2	2		1
Confl. Bikes (#/hr)		1			3							
Heavy Vehicles (%)	0%	2%	2%	0%	1%	0%	3%	0%	0%	1%	0%	0%
Turn Type	Prot			Prot			Perm		Perm	Perm		Perm
Protected Phases	5	2		1	6			8				4
Permitted Phases							8		8	4		4
Actuated Green, G (s)	14.5	38.4		0.8	24.7			10.9	10.9		10.9	10.9
Effective Green, g (s)	15.0	38.9		1.3	25.2			11.4	11.4		11.4	11.4
Actuated g/C Ratio	0.22	0.57		0.02	0.37			0.17	0.17		0.17	0.17
Clearance Time (s)	6.0	6.0		6.0	6.0			6.0	6.0		6.0	6.0
Vehicle Extension (s)	2.3	2.5		2.4	2.5			2.4	2.4		2.3	2.3
Lane Grp Cap (vph)	771	1991		34	1297			206	267		209	267
v/s Ratio Prot	c0.16	0.19		0.01	c0.24							
v/s Ratio Perm								c0.10	0.00		0.09	0.04
v/c Ratio	0.71	0.34		0.47	0.66			0.57	0.01		0.56	0.21
Uniform Delay, d1	24.5	7.8		33.1	17.9			26.1	23.6		26.0	24.5
Progression Factor	1.00	1.00		1.00	1.00			1.00	1.00		1.00	1.00
Incremental Delay, d2	2.6	0.1		6.6	1.2			3.0	0.0		2.3	0.2
Delay (s)	27.2	7.8		39.7	19.0			29.1	23.6		28.3	24.7
Level of Service	C	A		D	B			C	C		C	C
Approach Delay (s)		16.5			19.4			28.6			25.6	
Approach LOS		B			B			C			C	

























Intersection Summary

HCM Average Control Delay	19.6	HCM Level of Service	B
HCM Volume to Capacity ratio	0.66		
Actuated Cycle Length (s)	68.1	Sum of lost time (s)	16.5
Intersection Capacity Utilization	65.6%	ICU Level of Service	C
Analysis Period (min)	15		

c Critical Lane Group

HCM Signalized Intersection Capacity Analysis
 17: Tualatin Sherwood Rd & Martinazzi Ave

4/17/2013

												
Movement	EBL	EBT	EBR	WBL	WBT	WBR	NBL	NBT	NBR	SBL	SBT	SBR
Lane Configurations		 			 						 	
Volume (vph)	75	1194	141	0	1163	0	100	225	252	129	415	93
Ideal Flow (vphpl)	1900	1900	1900	1900	1900	1900	1900	1900	1900	1900	1900	1900
Total Lost time (s)	4.5	5.5			5.5		4.5	5.5	5.5	4.5	5.5	
Lane Util. Factor	1.00	0.95			0.95		1.00	1.00	1.00	1.00	0.95	
Frbp, ped/bikes	1.00	1.00			1.00		1.00	1.00	0.96	1.00	1.00	
Flpb, ped/bikes	1.00	1.00			1.00		1.00	1.00	1.00	1.00	1.00	
Frt	1.00	0.98			1.00		1.00	1.00	0.85	1.00	0.97	
Flt Protected	0.95	1.00			1.00		0.95	1.00	1.00	0.95	1.00	
Satd. Flow (prot)	1719	3430			3438		1770	1863	1537	1787	3466	
Flt Permitted	0.95	1.00			1.00		0.95	1.00	1.00	0.95	1.00	
Satd. Flow (perm)	1719	3430			3438		1770	1863	1537	1787	3466	
Peak-hour factor, PHF	0.94	0.94	0.94	0.94	0.94	0.94	0.94	0.94	0.94	0.94	0.94	0.94
Adj. Flow (vph)	80	1270	150	0	1237	0	106	239	268	137	441	99
RTOR Reduction (vph)	0	6	0	0	0	0	0	0	104	0	19	0
Lane Group Flow (vph)	80	1414	0	0	1237	0	106	239	164	137	521	0
Confl. Peds. (#/hr)							6		23			3
Heavy Vehicles (%)	5%	4%	0%	0%	5%	0%	2%	2%	1%	1%	1%	1%
Turn Type	Prot						Prot		Perm	Prot		
Protected Phases	5	2			6		3	8		7	4	
Permitted Phases									8			
Actuated Green, G (s)	8.6	66.5			52.9		10.6	17.9	17.9	13.6	20.9	
Effective Green, g (s)	9.1	67.0			53.4		11.1	18.4	18.4	14.1	21.4	
Actuated g/C Ratio	0.08	0.58			0.46		0.10	0.16	0.16	0.12	0.19	
Clearance Time (s)	5.0	6.0			6.0		5.0	6.0	6.0	5.0	6.0	
Vehicle Extension (s)	2.0	3.5			3.5		3.0	2.0	2.0	3.0	2.0	
Lane Grp Cap (vph)	136	1998			1596		171	298	246	219	645	
v/s Ratio Prot	0.05	c0.41			c0.36		0.06	c0.13		0.08	c0.15	
v/s Ratio Perm									0.11			
v/c Ratio	0.59	0.71			0.78		0.62	0.80	0.67	0.63	0.81	
Uniform Delay, d1	51.1	17.0			25.8		49.9	46.5	45.4	47.9	44.8	
Progression Factor	1.00	1.00			0.56		1.00	1.00	1.00	1.00	1.00	
Incremental Delay, d2	4.1	2.1			3.0		6.5	13.6	5.2	5.5	7.0	
Delay (s)	55.3	19.2			17.5		56.5	60.1	50.6	53.4	51.8	
Level of Service	E	B			B		E	E	D	D	D	
Approach Delay (s)		21.1			17.5			55.3			52.1	
Approach LOS		C			B			E			D	
Intersection Summary												
HCM Average Control Delay			30.4				HCM Level of Service			C		
HCM Volume to Capacity ratio			0.83									
Actuated Cycle Length (s)			115.0				Sum of lost time (s)		22.0			
Intersection Capacity Utilization			81.1%				ICU Level of Service		D			
Analysis Period (min)			15									
c Critical Lane Group												

HCM Unsignalized Intersection Capacity Analysis
 22: SW Boones Ferry Rd & RIRO North Access

4/17/2013



Movement	EBL	EBR	NBL	NBR	SWL	SWR
Lane Configurations	Y			Y		Y
Volume (veh/h)	822	23	0	49	0	747
Sign Control	Free		Stop		Free	
Grade	0%		0%		0%	
Peak Hour Factor	0.92	0.92	0.92	0.92	0.92	0.92
Hourly flow rate (vph)	893	25	0	53	0	812
Pedestrians						
Lane Width (ft)						
Walking Speed (ft/s)						
Percent Blockage						
Right turn flare (veh)						
Median type	None			None		
Median storage (veh)						
Upstream signal (ft)	324					
pX, platoon unblocked			0.77	0.77	0.77	
vC, conflicting volume			1718	906	918	
vC1, stage 1 conf vol						
vC2, stage 2 conf vol						
vCu, unblocked vol			1783	728	745	
tC, single (s)			6.4	6.2	4.1	
tC, 2 stage (s)						
tF (s)			3.5	3.3	2.2	
p0 queue free %			100	84	100	
cM capacity (veh/h)			69	326	664	
Direction, Lane #	EB 1	NB 1	SW 1			
Volume Total	918	53	812			
Volume Left	0	0	0			
Volume Right	25	53	0			
cSH	1700	326	1700			
Volume to Capacity	0.54	0.16	0.48			
Queue Length 95th (ft)	0	15	0			
Control Delay (s)	0.0	18.2	0.0			
Lane LOS		C				
Approach Delay (s)	0.0	18.2	0.0			
Approach LOS		C				
Intersection Summary						
Average Delay			0.5			
Intersection Capacity Utilization		50.3%		ICU Level of Service	A	
Analysis Period (min)		15				

Service Provider Letter

13-000801

This form and the attached conditions will serve as your Service Provider Letter in accordance with Clean Water Services Design and Construction Standards (R&O 07-20).

Jurisdiction: City of Tualatin **Review Type:** No Impact
Site Address / Location: 7055 SW Nyberg ST **SPL Issue Date:** April 04, 2013
Tualatin, OR 97062 **SPL Expiration Date:** April 04, 2015

Applicant Information:

Name MICHAEL CERBONE
 Company CARDNO
5415 SW WESTGATE DRIVE SUITE 100
 Address PORTLAND, OR 97221
 Phone/Fax (503) 419-2500
 E-mail: Michael.cerbone@cardno.com

Owner Information:

Name NYBERG LIMITED PARTNERSHIP
 Company (MULTIPLE OWNERS)
 Address _____
 Phone/Fax _____
 E-mail: _____

Tax lot ID

2S124A002502, 002507,
 2S124A002700,
 2S124B002100,
 2S124A002506, 002508,
 2S124B001601, 001602,
 001900, 002000, 002001,
 2S124B001601

Development Activity

Multi Lot Commercial

Pre-Development Site Conditions:

Sensitive Area Present: On-Site Off-Site
 Vegetated Corridor Width: 125
 Vegetated Corridor Condition: Good/Marginal

Post Development Site Conditions:

Sensitive Area Present: On-Site Off-Site
 Vegetated Corridor Width: 125

Enhancement of Remaining Vegetated Corridor Required:

Square Footage to be enhanced: 67,133

Encroachments into Pre-Development Vegetated Corridor:

Type and location of Encroachment: No Encroachment Proposed; Future Development of the Trail Square Footage: 0

Mitigation Requirements:

Type/Location No Mitigation Required Sq. Ft./Ratio/Cost 0

Conditions Attached Development Figures Attached (3) Planting Plan Attached Geotech Report Required

This Service Provider Letter does NOT eliminate the need to evaluate and protect water quality sensitive areas if they are subsequently discovered on your property.

In order to comply with Clean Water Services water quality protection requirements the project must comply with the following conditions:

1. No structures, development, construction activities, gardens, lawns, application of chemicals, uncontained areas of hazardous materials as defined by Oregon Department of Environmental Quality, pet wastes, dumping of materials of any kind, or other activities shall be permitted within the sensitive area or Vegetated Corridor which may negatively impact water quality, except those allowed in R&O 07-20, Chapter 3.
2. Prior to any site clearing, grading or construction the Vegetated Corridor and water quality sensitive areas shall be surveyed, staked, and temporarily fenced per approved plan. During construction the Vegetated Corridor shall remain fenced and undisturbed except as allowed by R&O 07-20, Section 3.06.1 and per approved plans.
3. If there is any activity within the sensitive area, the applicant shall gain authorization for the project from the Oregon Department of State Lands (DSL) and US Army Corps of Engineers (USACE). The applicant shall provide Clean Water Services or its designee (appropriate city) with copies of all DSL and USACE project authorization permits.
4. An approved Oregon Department of Forestry Notification is required for one or more trees harvested for sale, trade, or barter, on any non-federal lands within the State of Oregon.
5. **Prior to ground disturbance, an Erosion Control Permit is required through the City. Appropriate Best Management Practices (BMP's) for Erosion Control, in accordance with Clean Water Services' Erosion Prevention and Sediment Control Planning and Design Manual, shall be used prior to, during, and following earth disturbing activities.**
6. Prior to construction, a Stormwater Connection Permit from Clean Water Services or its designee is required pursuant to Ordinance 27, Section 4.B.
7. Activities located within the 100-year floodplain shall comply with R&O 07-20, Section 5.10.
8. Removal of native, woody vegetation shall be limited to the greatest extent practicable.
9. The water quality facility shall be planted with Clean Water Services approved native species, and designed to blend into the natural surroundings.
10. **Should final development plans differ significantly from those submitted for review by Clean Water Services, the applicant shall provide updated drawings, and if necessary, obtain a revised Service Provider Letter.**

SPECIAL CONDITIONS

11. The Vegetated Corridor width for sensitive areas within the project site shall be a minimum of 125 feet wide, as measured horizontally from the delineated boundary of the sensitive area.
12. **For Vegetated Corridors greater than 50 feet in width, the applicant shall enhance the first 50 feet closest to the sensitive area to meet or exceed good corridor condition as defined in R&O 07-20, Section 3.14.2, Table 3-3.**
13. Prior to any site clearing, grading or construction, the applicant shall provide Clean Water Services or the City with a Vegetated Corridor enhancement/restoration plan. Enhancement/restoration of the Vegetated Corridor shall be provided in accordance with R&O 07-20, Appendix A, and shall include planting specifications for all Vegetated Corridor, including any cleared areas larger than 25 square feet in Vegetated Corridor rated ""good.""
14. **Prior to installation of plant materials, all invasive vegetation within the Vegetated Corridor shall be removed per methods described in Clean Water Services' Integrated Pest Management Guide, 2009. During removal of invasive vegetation care shall be taken to minimize impacts to existing native tree and shrub species.**
15. Clean Water Services or the City shall be notified 72 hours prior to the start and completion of enhancement/restoration activities. Enhancement/restoration activities shall comply with the guidelines provided in Landscape Requirements (R&O 07-20, Appendix A).

16. **Maintenance and monitoring requirements shall comply with R&O 07-20, Section 2.11.2. If at any time during the warranty period the landscaping falls below the 80% survival level, the owner shall reinstall all deficient planting at the next appropriate planting opportunity and the two year maintenance period shall begin again from the date of replanting.**
17. **Performance assurances for the Vegetated Corridor shall comply with R&O 07-20, Section 2.06.2.**
18. **For any developments which create multiple parcels or lots intended for separate ownership, Clean Water Services may require that the sensitive area and Vegetated Corridor be contained in a separate tract and subject to a "STORM SEWER, SURFACE WATER, DRAINAGE AND DETENTION EASEMENT OVER ITS ENTIRETY" to be granted to the City or Clean Water Services.**

FINAL PLANS

19. **Final construction plans shall include landscape plans.** In the details section of the plans, a description of the methods for removal and control of exotic species, location, distribution, condition and size of plantings, existing plants and trees to be preserved, and installation methods for plant materials is required. Plantings shall be tagged for dormant season identification and shall remain on plant material after planting for monitoring purposes.
20. **A Maintenance Plan** shall be included on final plans including methods, responsible party contact information, and dates (minimum two times per year, by June 1 and September 30).
21. **Final construction plans shall clearly depict the location and dimensions of the sensitive area and the Vegetated Corridor** (indicating good, marginal, or degraded condition). Sensitive area boundaries shall be marked in the field.
22. Protection of the Vegetated Corridors and associated sensitive areas shall be provided by the installation of signage between the development and the outer limits of the Vegetated Corridors. **Signage details to be included on final construction plans.**

This Service Provider Letter is not valid unless CWS-approved site plan is attached.

Please call (503) 681-3653 with any questions.



**Amber Wierck
Environmental Plan Review**

Attachments (3)

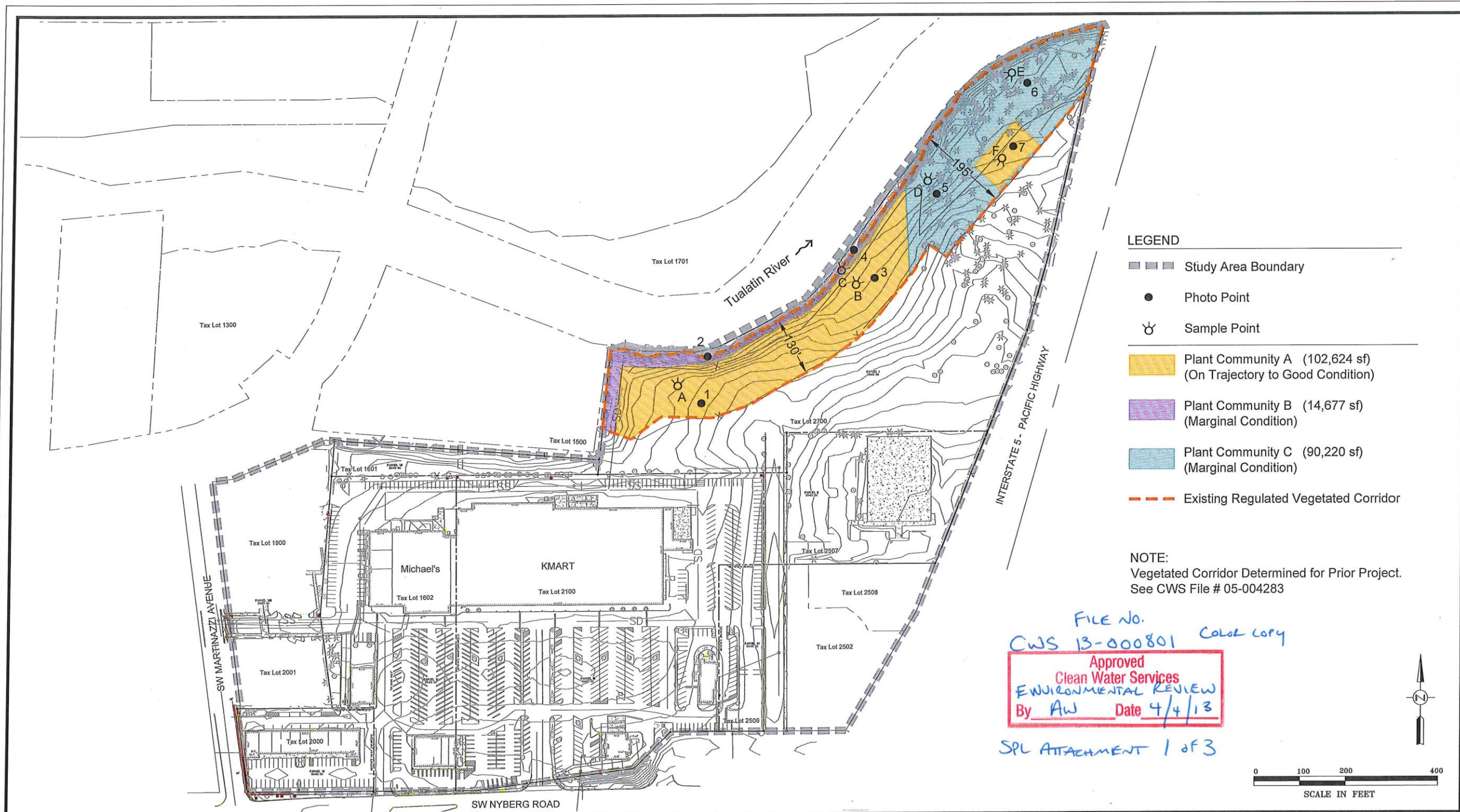

Base map provided by CARDNO WRG.

Existing Conditions
Nyberg Rivers Commercial Retail Development- Tualatin, Oregon

FIGURE
2
03-07-2013

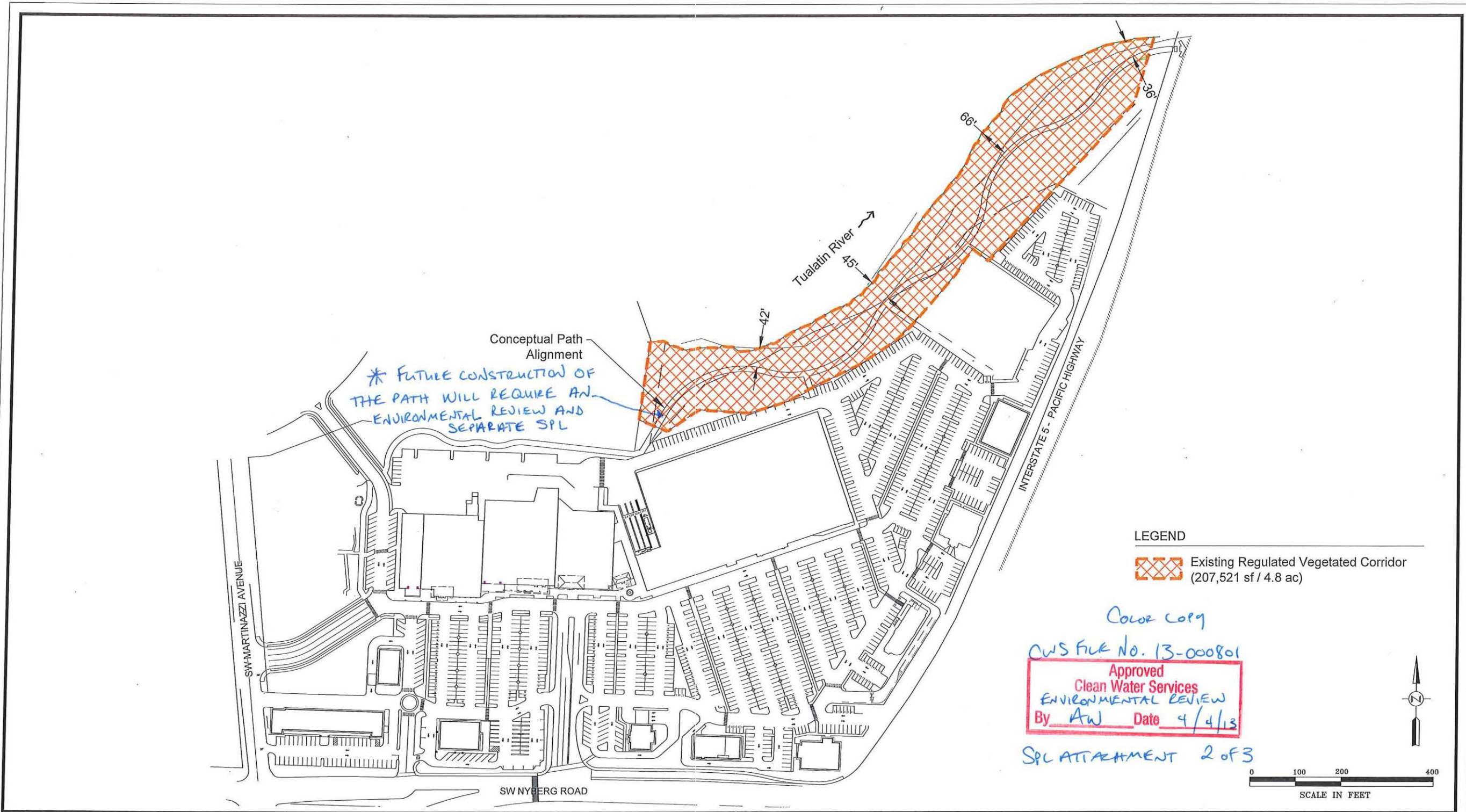

Note:
 Base Map provided by CARDNO WRG.

Proposed Development Plan
 Nyberg Rivers Commercial Retail Development- Tualatin, Oregon

FIGURE
3

03-07-2013

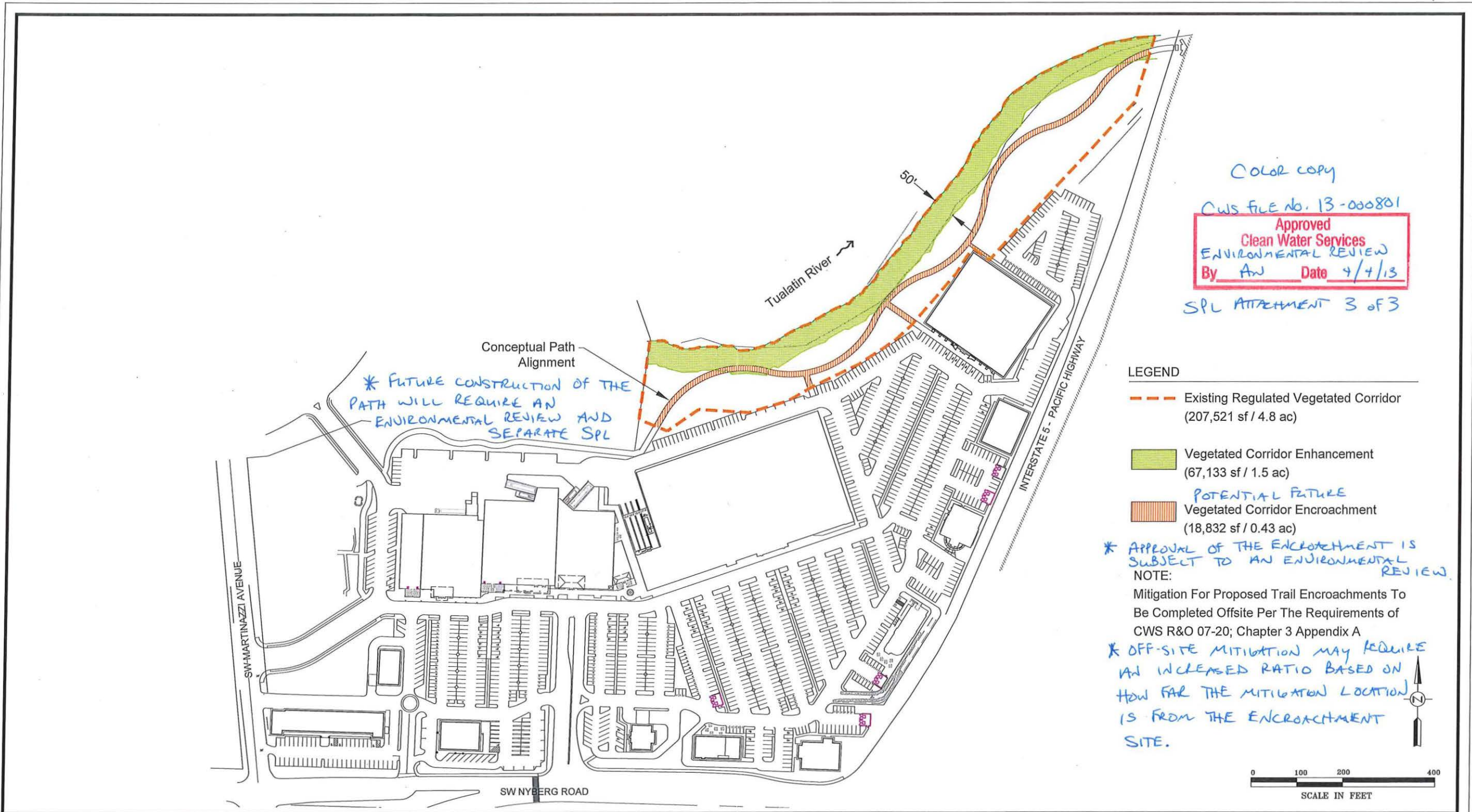

COLOR COPY
 CWS FILE No. 13-000801
 Approved
 Clean Water Services
 ENVIRONMENTAL REVIEW
 By AW Date 4/4/13
 SPL ATTACHMENT 3 OF 3

LEGEND

- Existing Regulated Vegetated Corridor (207,521 sf / 4.8 ac)
- Vegetated Corridor Enhancement (67,133 sf / 1.5 ac)
- POTENTIAL FUTURE Vegetated Corridor Encroachment (18,832 sf / 0.43 ac)

* APPROVAL OF THE ENCROACHMENT IS SUBJECT TO AN ENVIRONMENTAL REVIEW.
 NOTE:
 Mitigation For Proposed Trail Encroachments To Be Completed Offsite Per The Requirements of CWS R&O 07-20; Chapter 3 Appendix A
 * OFF-SITE MITIGATION MAY REQUIRE AN INCREASED RATIO BASED ON HOW FAR THE MITIGATION LOCATION IS FROM THE ENCROACHMENT SITE.

Note:
 Base map provided by CARDNO WRG.

Vegetated Corridor Encroachment and Necessary Enhancements
 Nyberg Rivers Commercial Retail Development- Tualatin, Oregon

FIGURE
 4

03-07-2013



**Natural Resource Assessment
for the Nyberg Rivers
Commercial and Retail Development
in Tualatin, Oregon**

(Township 2 South, Range 1 West, Section 24A & 24B)

Prepared for

CenterCal Properties, LLC
7455 SW Bridgeport Road, Suite 205
Tigard, Oregon 97224

Prepared by

Pacific Habitat Services, Inc.
Wilsonville, Oregon 97070
(503) 570-0800
(503) 570-0855 FAX

March 14, 2013



**Natural Resource Assessment
for the Nyberg Rivers
Commercial and Retail Development
in Tualatin, Oregon**

(Township 2 South, Range 1 West, Section 24A & 24B)

Prepared for

Hank Murphy

CenterCal Properties, LLC

7455 SW Bridgeport Road, Suite 205
Tigard, Oregon 97224

Prepared by

Shawn Eisner

Pacific Habitat Services, Inc.

9450 SW Commerce Circle, Suite 180
Wilsonville, Oregon 97070
(503) 570-0800
(503) 570-0855 FAX
PHS Project Number: 5141

March 14, 2013

TABLE OF CONTENTS

	<u>Page</u>
1.0 INTRODUCTION.....	1
2.0 EXISTING CONDITIONS	1
3.0 DISCUSSION OF WATER QUALITY SENSITIVE AREAS.....	1
4.0 VEGETATED CORRIDOR ASSESSMENT.....	2
4.1 Vegetated Corridor Width Determination	2
4.2 Vegetated Corridor Plant Communities	2
4.3 Vegetated Corridor Plant Community Condition.....	3
5.0 PROPOSED PROJECT	3
5.1 Project Overview	3
5.2 Vegetated Corridor Enhancements.....	4
5.3 Vegetated Corridor Encroachments.....	5
5.4 Proposed Vegetated Corridor Mitigation	5
5.5 Alternative Analysis	6
 APPENDIX A: Figures	
APPENDIX B: Nyberg II Wetland Determination Memo	
APPENDIX C: Vegetated Corridor Sample Points Table & Photodocumentation	
APPENDIX D: NRA Definitions and Methodology and References	

1.0 INTRODUCTION

Pacific Habitat Services, Inc. (PHS) conducted a natural resource assessment for Nyberg Rivers, a proposed retail and commercial development project in Tualatin, Oregon. The project is located north of Nyberg Road, just west of I-5 in the 7400 to 7900 blocks of SW Nyberg Road in Tualatin, Oregon (Township 2 South, Range 1 West, Section 24A tax lots 2502, 2506, 2507, 2508 & 2700 and Section 24B tax lots 1601, 1602, 1900, 2000, 2001 & 2100). Figure 1 shows the approximate location of the nearly 29-acre site; all figures are in Appendix A. This report presents the definitions and the methodology used to assess the natural resources on the site, as well as proposed vegetated corridor encroachments, as required by CWS.

2.0 EXISTING CONDITIONS

The project site is bounded generally by the Tualatin River to the north; SW Martinazzi Avenue and adjoining development to the west; SW Nyberg Road to the south; and Interstate 5 to the east. It includes a mix of existing commercial and retail spaces; previously developed but currently unoccupied properties; as well as undeveloped grass and forest land. The undeveloped areas include three general categories of vegetative cover; forested areas west of I-5 and along the south bank of the Tualatin River; a swath of native vegetation enhancements approximately 125 feet wide that begin south of the Tualatin River; and fallow grassland, which lies between existing development and the forested and enhanced areas to the north and east. The forested and enhancement areas are overwhelmingly dominated by upland plant species, though tree and shrub species that prefer moist conditions, such as Oregon ash and western red cedar, are present within the riparian areas along the river.

South of the undeveloped grasslands the site is nearly fully paved. It includes numerous existing businesses, vacant buildings, a former building pad, and many acres of parking lot.

3.0 DISCUSSION OF WATER QUALITY SENSITIVE AREAS

The Natural Resource Assessment field work and data collection are a compilation of work completed in two phases. Initially, a wetland determination was completed on November 15, 2011. PHS returned to the site on March 5, 2013, to confirm the prior assessment and to collect data associated with existing vegetated corridors. These site visits have confirmed that the Tualatin River is the only sensitive area on or immediately adjoining the site. Appendix B includes a determination letter and data points from the November 2011 assessment that confirm this assessment.

The current work did not include confirming the edge of the Tualatin River. Its location was determined in 2005 when this site was utilized as an offsite mitigation area for Nyberg Woods, a commercial/retail development located east of I-5, just downstream from this site (see existing CWS file number 05-004283). It is presumed that the prior work that defined the edge of the river utilized the location of the 2 year surface water elevation, which has been calculated by Pacific Water Resources, for Watershed Management at Clean Water Services. The 2 year surface water elevation, as calculated by the model, is located just below 112 feet near the west end of the site and decreases slightly, to 111.4 at the I-5 Tualatin River Bridge at the east end of the site. The northern boundary of the vegetated corridor as shown on Figure 2 follows the 112 contour line.

4.0 VEGETATED CORRIDOR ASSESSMENT

4.1 Vegetated Corridor Width Determination

The location and widths of vegetated corridors on the site are shown on Figure 2. While slopes immediately along the Tualatin River exceed 25%, slopes a distance of 50 to 75 feet from the river are much flatter. As a result of slopes less than 25% within 50 feet, the standard corridor width of 125 feet for the Tualatin River will apply. This original width determination was made as part of another development project which utilized a portion of the vegetated corridor on this site as mitigation for offsite vegetated corridor encroachment. The vegetated corridor as shown on Figure 2 exceeds the 125 foot minimum for much of its length. This is the result of corridor expansion related to the previously mentioned offsite project.

4.2 Vegetated Corridor Plant Communities

The vegetated corridor south of the Tualatin River is comprised of three plant communities (Figure 2). A discussion of each community is included below. Vegetative sample sites were chosen at representative locations throughout the project area. A single table in Appendix C includes all vegetation data points, organized by community. Appendix C also includes photographs of each community.

Community A (102,624 square feet) includes that portion of the vegetated corridor that has seen previous enhancement. Enhancement in this area was tied to development on another property. The initial enhancement occurred in 2007. Prior to enhancement this area was a grass or grain field. Community A is dominated by native tree and shrub plantings at densities very near CWS current standards. The herbaceous layer lacks native vegetation and due to the fact that the tree saplings range in height from about 5 to 15 feet there is no tree canopy within the community. In general there are few invasive species, though Himalayan blackberry, Scotch broom, and thistles are all present.

Community B (14,677 square feet) includes the southern limits of the forested riparian area along the Tualatin River. Across the western portion of the site this community is generally 10 to 25 feet wide. Though the actual riparian area is about 40 feet wide, only the southern extent is located beyond the 2-year storm elevation and therefore outside of the defined sensitive area. Despite the narrow width of the riparian area, the tree canopy is quite dense, ranging from 85 to 100 percent and is composed almost entirely of native trees. The shrub layer is variable; open in some areas and more dense in others. The denser areas tend to be dominated by invasive species, such as Himalayan blackberry and Scotch broom. Where more open, snowberry, trailing blackberry, and tall Oregon grape are more common. Like the mid-story, ground cover is variable. In large areas English ivy dominates the understory and there are, as a result, only a few sword fern or grasses that rise above the ivy. Where ivy is lacking, and the area is not overrun with blackberries, there is a more diverse mix of grasses and forbs, though natives are not common. The transition from forested conditions in Community B to the assemblage of enhancement plantings and grasses in Community A is quite abrupt, the apparent result of vegetation management in the enhancement area.

Community C (90,220 square feet) encompasses that portion of the vegetated corridor east of Communities A and B. This area includes a mature stand of Douglas fir, with additional common species including big leaf maple and western red cedar. Other native and non-native trees, such as Oregon white oak, sweet cherry, and English hawthorn are present but represent a very small percentage of the overall community. Unlike Community A, which has moderate to dense shrub layer, this forested area is quite open. Shrubs are not common, and where present, are generally represented by small thickets or individual shrubs of Himalayan blackberry. Snowberry is present, as are tall Oregon grape and Indian plum but they are scattered or found in small groupings. Groundcover is a patchwork mosaic of English ivy, mixed non-native grasses, geranium species, and bare ground. Documented invasive species include Himalayan blackberry, English ivy, and a small area of reed canarygrass.

4.3 Vegetated Corridor Plant Community Condition

Table 1 shows the percent composition of native versus non- native species, and tree canopy cover in accordance with Clean Water Services’ standards. Appendix C includes a table of all species documented at each sample point. The table is followed by photodocumentation of each community.

Table 1. Summary of Plant Communities

Corridor Condition		Plant Communities		
		A	B	C
Good	>80% cover of native plants, and >50% tree canopy		93% canopy	88% canopy
Marginal	50% - 80% cover of native plants, and 26-50% tree canopy			
Degraded	<50% cover of native plants, and ≤ 25% tree canopy	38% natives 0% canopy	48% natives	48% natives

The condition of the vegetated corridor is defined by the percentages of native species and canopy cover. As the enhancement area (Plant Community A) has not yet matured, the predominance of native vegetation is not enough to offset the predominance of non-native herbaceous species. As a result, this community remains in degraded condition, though based upon the presumption of continued plant survival is ‘on trajectory for good condition’. Communities B and C maintain good tree canopies, but there are few natives in the mid and ground story. This is due primarily to the high percentage of cover by non-native grasses and forbs, English ivy and/or Himalayan blackberry. As a result, each of these communities warrants an overall community condition of ‘marginal.’

5.0 PROPOSED PROJECT

5.1 Project Overview

The proposed project as shown on Figure 3 includes new construction as well as modifications to existing buildings and parking areas. The new development will also expand into currently undeveloped land behind (north of) the existing commercial area. Existing structures along

Nyberg Road and Martinazzi Avenue will remain, as well the Michael's craft store. The existing Kmart building will be removed to facilitate a new anchor store and expansion/modification of the existing parking areas. The development will also allow for additional building pads along the east and north east portions of the site. All of these elements are located south of the regulated vegetated corridor.

The applicant is proposing to provide an easement for the future construction of a pathway. A conceptual path alignment is shown on Figure 3, with anticipated encroachment totals shown on Figure 4. The final location of the path will be subject to review and approval by the City of Tualatin; the alignment as shown may need to be modified but is believed to be sufficient to determine project intent and to analyze and calculate vegetated corridor encroachments. Though the path will pass through previously enhanced as well as forested areas, it is the applicant's intent to allow for flexibility in the final alignment to avoid as much native vegetation in the previously enhanced area as possible. Within the forested area, the mature trees are quite far apart and it will be possible to avoid all but a few trees in the northeast corner, just west of an existing bridge. The applicant is proposing an easement to accommodate a future path through the vegetated corridor but wants it to have as little impact on existing vegetation as possible.

5.2 Vegetated Corridor Enhancements

Though the project includes future encroachment for an easement for a future pedestrian path system in the vegetated corridor, the path will largely be located in the central and outer portions of the vegetated corridor (see Section 5.0 below) and as a result, 67,133 square feet of corridor enhancement will occur per CWS standards. As the vegetated corridor is in excess of 50 feet wide, the 50 feet closest to the Tualatin River will be enhanced to meet good corridor condition (see Figure 4). This will include maintenance and limited plantings within the previously enhanced areas at the northern limits of Community A, as well as more significant efforts in Communities B and C along the Tualatin River. Though the timing of path construction in relation to the overall project is not known, vegetated corridor enhancement will occur concurrent with or immediately following development of the commercial and retail areas. Preceding the installation of plantings, all invasive species as identified by CWS will be removed. Species observed in one or more areas include Himalayan blackberry, English ivy, Scotch broom, reed canarygrass, as well as bull and Canada thistle.

Enhancement will be consistent with Clean Water Services' standards (refer to *Appendix A: Planting Requirements* of R&O 07-20). The overall goal will be to restore all plant communities to "good" condition, as required by Clean Water Services. Due to the overwhelmingly native tree canopy in Communities B and C, and the existing density of tree saplings in Community A, enhancement measures will focus on the establishment of a native shrub layer, with additional herbaceous plantings as well. A formal planting plan for on-site enhancements is not included with this report but will be provided for CWS review and approval concurrent with engineering review of the project.

5.3 Vegetated Corridor Encroachments

Though the vegetated corridor was utilized as mitigation of one form or another for a prior development, paths are being proposed across the site in order to line up with proposed paths east of the site, as well as to fulfill the City of Tualatin's strategy to develop a complete network of paths along the Tualatin River. The proposed path will be composed of concrete and will be 10 feet wide with one-foot shoulders on either side. The path will begin outside the vegetated corridor, near the west side of the site, and enter the corridor approximately 600 feet to the east. From its point of entry into the corridor, the path will approach the river at several locations but will remain at least 30 feet from the river. The path will also include sections that pass closer to the outer limits of the corridor where side paths will provide access to the main path. The western and central arterial paths will also be 10 feet wide with 1 foot shoulders, with the eastern path at 6 feet wide, including shoulders. North and east of the development the path will continue through the outer (southern) portion of the forested area, approaching the Tualatin River in the very northeast portion of the site where the path is proposed to pass beneath the existing I-5 Tualatin River Bridge and connect to additional offsite paths proposed in that area. In order to pass beneath the bridge, the path is required to approach the Tualatin River closer than is necessary for the remainder of the path. In this area it will be necessary for the path to be within 30 feet of the river. The combined area of all proposed path encroachments as described above is 18,832 square feet (0.43 acre). Mitigation for proposed encroachments is discussed in Section 5.4 below.

As all but the easternmost extent of the path is located beyond 30 feet from the Tualatin River, only that section near the river would not be considered an allowed use. This "non-allowed" section would therefore need to be examined and approved by CWS through a Tier 2 analysis. As the current path alignment is conceptual, the precise area of Tier 2 encroachment has not been identified, though it has been anticipated within this submittal (see Section 5.4 Alternatives Analysis).

5.4 Proposed Vegetated Corridor Mitigation

Much, if not all, of the existing vegetated corridor on the site has been utilized as mitigation for the previously mentioned project (CWS File Number 05-004283). As a result, the possibilities for onsite mitigation are diminished. Despite this limitation, the applicant is reviewing onsite mitigation options. The applicant also intends to work with the City of Tualatin to identify offsite mitigation opportunities. The applicant is looking to work with the City and CWS to identify mitigation options that best balance the needs of the project and allow for mitigation to occur in an area where the greatest water quality benefit can be found, whether the location be on- or off-site.

The location of the mitigation site in relation to the development site will be very important and if off-site mitigation is required, every attempt to provide mitigation within one-quarter mile of the development site will be sought. If mitigation needs to occur at a greater distance, then mitigation will be provided at an increase ratio, as required by CWS regulations.

All mitigation will be consistent with Clean Water Services' standards (per Section 3.08 *Replacement Mitigation Standards*, and *Appendix A: Planting Requirements* of R&O 07-20). The overall goal will be to restore or create vegetated corridor to "good" condition.

5.4 Alternatives Analysis

As the entire vegetated corridor has already been utilized for vegetated corridor mitigation to one extent or another, avoiding existing corridor mitigation areas is not feasible. As the proposed path is required by the City of Tualatin, full avoidance of the vegetated corridor was not feasible. The applicant has sought to minimize encroachments of the path through its proposed placement. The only Tier 2 section of path is located in the northeast extent of the project area, where its proximity to the Tualatin River is necessary to pass beneath the existing bridge and access proposed paths to the east. As a result of this section of path, a Tier 2 Alternatives Analysis is required. The proposed project will meet all Tier 2 Alternative Analysis criteria; responses to the criteria are detailed below.

1. The proposed encroachment area is mitigated in accordance with Section 3.08.

Mitigation for 18,832 square feet (0.43 acre) of encroachment to the vegetated corridor for the easement for future path construction will be consistent with Clean Water Services' standards (per Section 3.08 *Replacement Mitigation Standards*, and *Appendix A: Planting Requirements* of R&O 07-20). The overall goal will be to restore or create vegetated corridor to "good" condition.

2. The replacement mitigation protects the functions and values of the Vegetated Corridor and Sensitive Area.

Mitigation for 18,832 square feet (0.43 acre) of encroachment to the vegetated corridor for path encroachments will be provided. Though a corridor mitigation plan has not been prepared, the applicant is committed to providing full mitigation for all encroachments at or above the standards required by CWS. Whether onsite or off, mitigation at the chosen site will focus on enhancement or restoration of conditions that protect adjoining sensitive areas and their regulated corridors.

3. Enhancement of the replacement area, if not already in Good Corridor Condition, and either the remaining Vegetated Corridor on the site or the first 50 feet of width closest to the resource, whichever is less, to a Good Corridor Condition.

The first 50 feet of vegetated corridor along the Tualatin River will be enhanced to good condition. This will include a portion of area that has seen prior enhancement, as well as riparian and upland forested areas. The total area of proposed enhancement will be 67,133 square feet (1.5 acres).

4. A District Stormwater Connection Permit is likely to be issued based on proposed plans.

The applicant reasonably expects to obtain a District Stormwater Connection Permit based on proposed plans for the project.

5. Location of development and site planning minimizes incursion into the Vegetated Corridor.

As the vegetated corridor on this site was determined as part of a prior development action, the current proposal places all new development, except for the pedestrian path, outside of the existing corridor. The path encroachments have been minimized to the extent practicable by keeping the path within allowed use areas of the corridor except where by necessity the path must approach the river to connect with proposed path sections east of the development site. The Tier 2 section of path is unavoidable, as the only other pedestrian option to areas east of I-5 is to route pedestrians south, back through the development, east over I-5 via Nyberg Road, and then north back through existing development and sensitive areas east of I-5; a distance of approximately three-quarters of a mile. As the path section east of I-5 has already been approved, the proposed route beneath the Tualatin River Bridge is the most straightforward connection to this section of path.

6. No practicable alternative to the location of the development exists that will not disturb the Sensitive Area or Vegetated Corridor.

As the intent of the path is to allow pedestrians an “off-street” alternative to access commercial and residential areas east of I-5, there are no development options that will not disturb the vegetated corridor.

As described above, the only alternative that avoids vegetated corridors is to require pedestrians to utilize existing and proposed sidewalks between the proposed development and existing development to the east. As the proposed project, as well as anticipated development east of I-5, will increase vehicular traffic in this area of Tualatin, a well-planned pedestrian alternative will encourage use of the path and perhaps an associated reduction in vehicular traffic.

7. The proposed encroachment provides public benefits.

The public benefit of vegetated corridor encroachment includes supporting City goals for increased pedestrian circulation via its ever growing network of paths along the Tualatin River. Increased pedestrian traffic should result in at least a localized reduction in vehicular traffic. It also increases the market for existing and future residential development east of I-5 because access to commercial and retail areas west of I-5 can be accessed without crossing vehicular traffic exiting and accessing I-5. Though a corridor mitigation plan has not been prepared, the applicant is committed to providing full mitigation for all encroachments at or above the standards required by CWS. In so doing, the mitigation area will be upholding CWS’ commitment to protecting water quality and the resources that depend upon clean water.

Appendix A

Figures



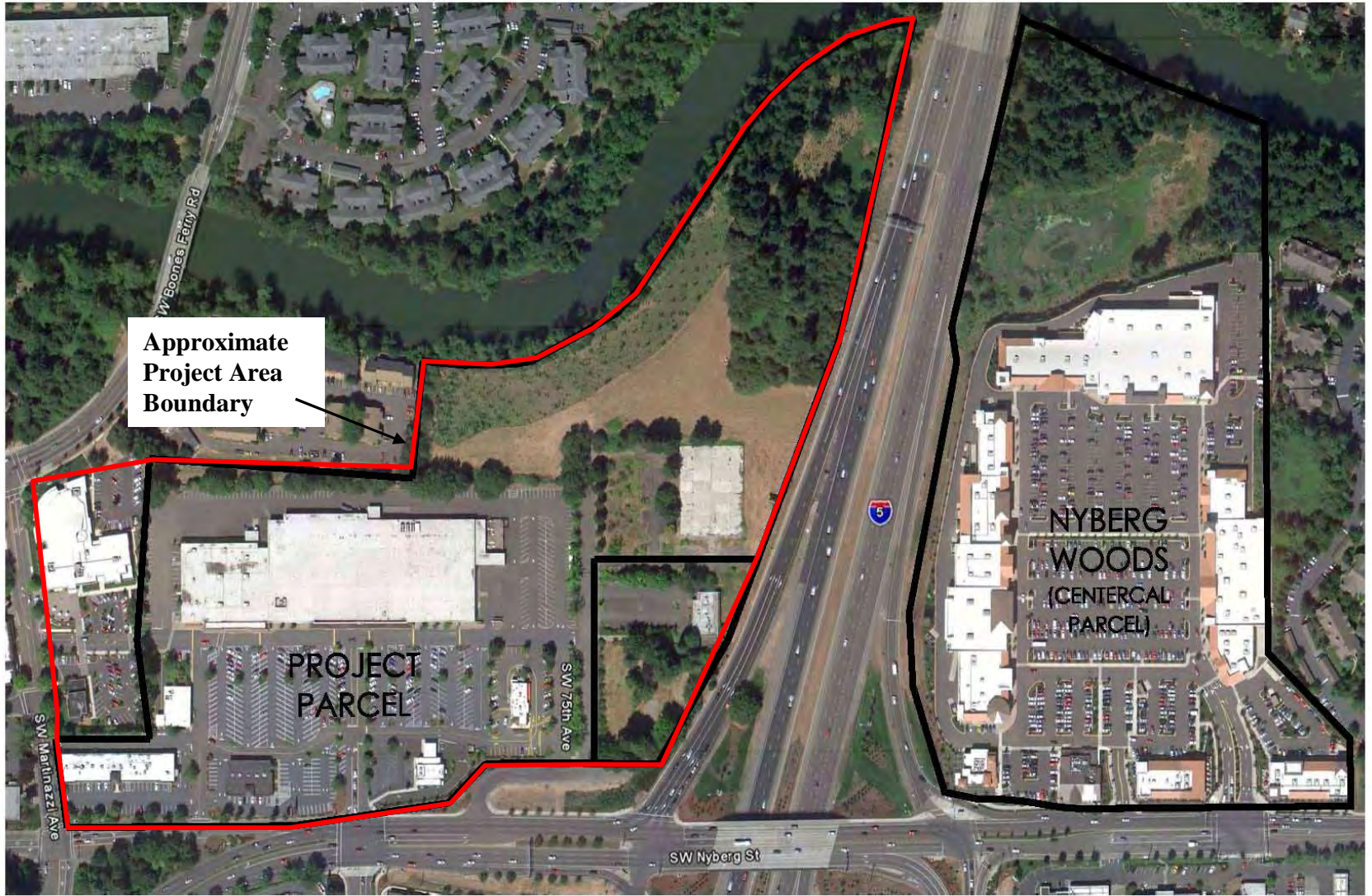

3/11/13

5141

FIGURE
1

Nyberg Rivers, a proposed commercial development west of I-5 in Tualatin , Oregon (Air photo base map provided by Cardno WRG, 2011).

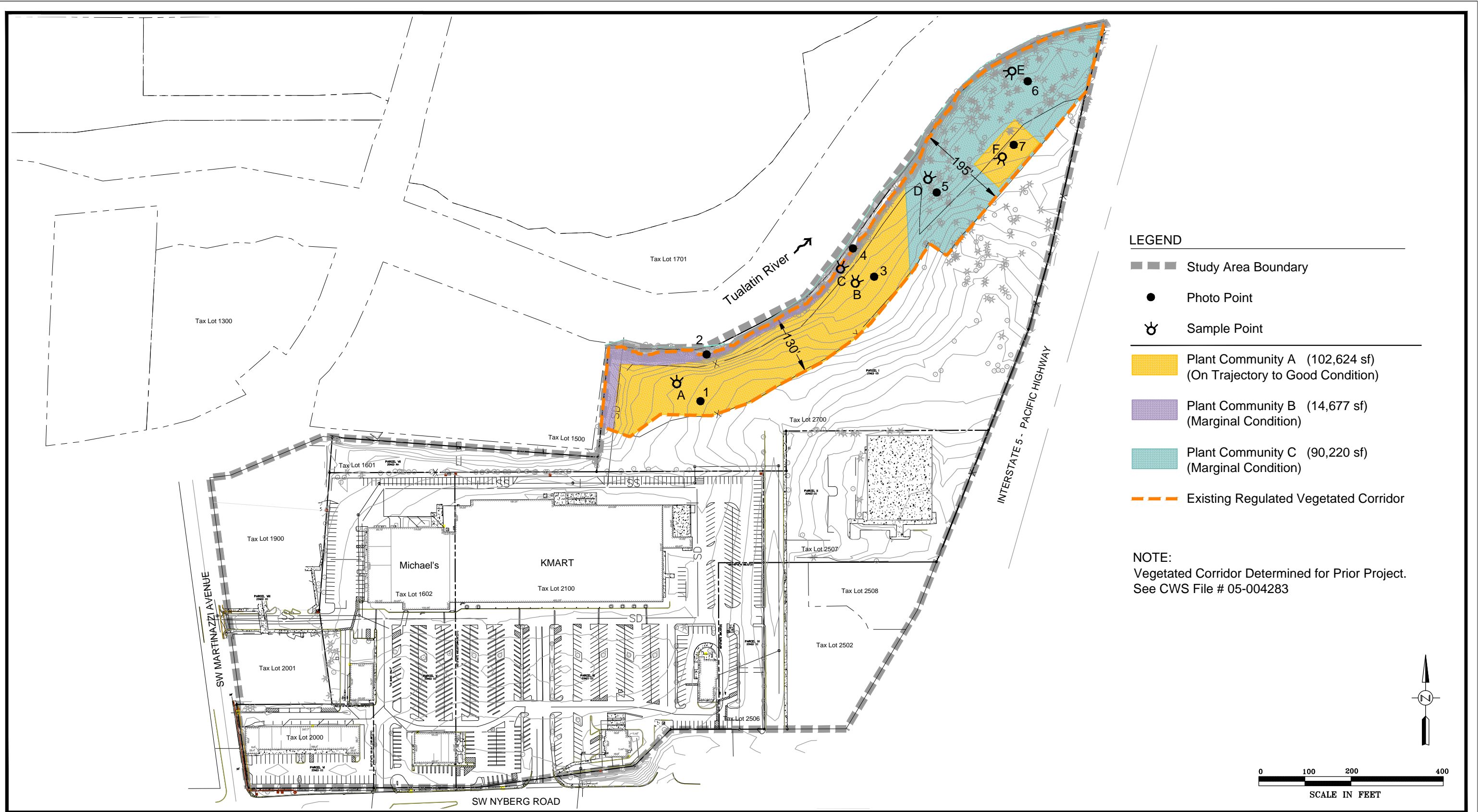

LEGEND

- ■ ■ Study Area Boundary
- Photo Point
- ☉ Sample Point
- Plant Community A (102,624 sf)
(On Trajectory to Good Condition)
- Plant Community B (14,677 sf)
(Marginal Condition)
- Plant Community C (90,220 sf)
(Marginal Condition)
- - - Existing Regulated Vegetated Corridor

NOTE:
Vegetated Corridor Determined for Prior Project.
See CWS File # 05-004283





Base map provided by CARDNO WRG.

Existing Conditions
Nyberg Rivers Commercial Retail Development- Tualatin, Oregon

FIGURE
2

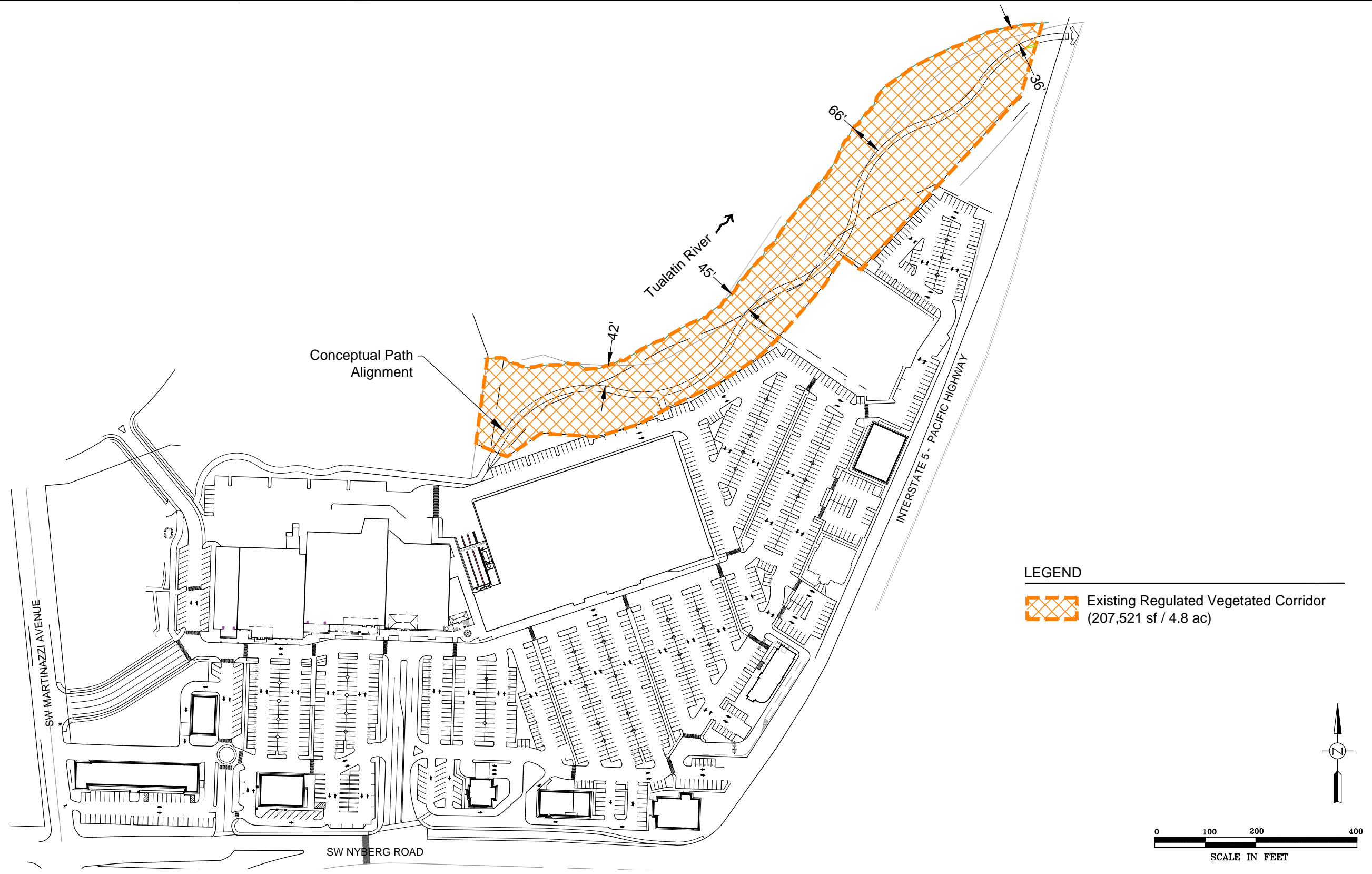
03-07-2013



LEGEND
 Existing Regulated Vegetated Corridor
 (207,521 sf / 4.8 ac)

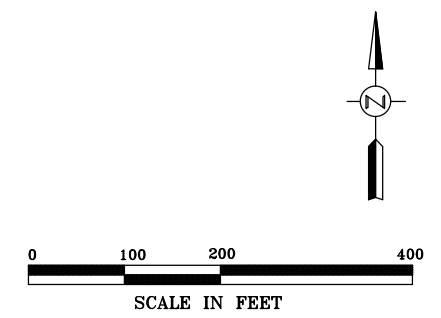

Note:
 Base Map provided by CARDNO WRG.

Proposed Development Plan
 Nyberg Rivers Commercial Retail Development- Tualatin, Oregon

FIGURE
3

03-07-2013



Note:
Base map provided by CARDNO WRG.

Vegetated Corridor Encroachment and Necessary Enhancements
Nyberg Rivers Commercial Retail Development- Tualatin, Oregon

FIGURE
4

03-07-2013

Appendix B

Nyberg II Wetland Determination Memo





November 21, 2011

Kevin Russell
Cardno WRG
5415 SW Westgate Drive Suite 100
Portland, Oregon 97221

**Re: Nyberg II; Wetland Determination
PHS Project # 4921**

Kevin:

The properties within the project parcel were visited by biologists at Pacific Habitat Services, Inc. (PHS) on November 15, 2011. This memo and associated figure and data sheets are being provided as documentation of our work. Figure 1 includes the limits of the study area as well as the location of two data points that were collected to document typical conditions. Our work confirmed that the Tualatin River is the only sensitive areas (wetland or waterway) within the project parcel.

Existing Conditions

Pacific Habitat Services, Inc. (PHS) completed a wetland determination of the project parcel, which is bounded generally by the Tualatin River to the north, SW Martinazzi Ave and adjoining development to the west, SW Nyberg St to the south, and Interstate 5 to the east. The study area included both commercially developed properties, and undeveloped forest and grassland.

Though we did investigate existing vegetated areas immediately adjoining the project boundaries, as well as along parking lots and driveways, the focus of the determination was undeveloped areas in the northern portion of the study area. The undeveloped areas include three general categories of vegetative cover; forested areas west of I-5 and along the south bank of the Tualatin River; a swath of native vegetation enhancements approximately 125 feet wide that begin south of the Tualatin River; and fallow grassland, which lies between existing development and the forested and enhanced areas to the north.

The forested and enhancement areas were overwhelmingly dominated by upland plant species, though tree and shrub species that prefer moist conditions, such as Oregon ash and western red cedar, are present within the riparian areas along the river. Soils were well drained and there was no evidence of ponding or flooding. The only evidence of hydrology was near the northern tip of the study area, where the roadside ditch along I-5 enters a small PVC pipe at the base of the roadway embankment. It appears that the flow path to the pipe is constricted and periodic

stormwater discharge onto the site via overtopping of the shallow ditch may occur. Soils in this area suggested a history of disturbance.

The fallow grassland is dominated by two common turf grass species; tall fescue and creeping bentgrass. Though it is not uncommon to find each of these species in wetlands, they grow equally well in drier conditions. Though fallow, it appears that the grassland is regularly mowed. The soils throughout the grassland appear well drained and there was no evidence of ponding or seasonally saturated soil conditions.

Air Photos & Mapping

A review of available natural resources mapping, as well as recent aerial photographs of the site confirms the results of the site work. The grassland area and the enhanced areas to the north were farmed until 2005. In late 2006 or early 2007 the corridor south of the Tualatin River was established and planted, though the remaining areas have remained as grass.

Other than the Tualatin River the City of Tualatin Local Wetland Inventory map does not identify wetlands or other water features. Likewise, mapped soil units suggest upland conditions and do not include hydric (wetland) soils.

Conclusion

Our on-site and off-site work indicates that the Tualatin River is the only potentially jurisdictional water feature within the designated study area. Feel free to contact me if you have any questions regarding the results of this wetland determination.

Thank you,



Shawn Eisner
Wetland Scientist

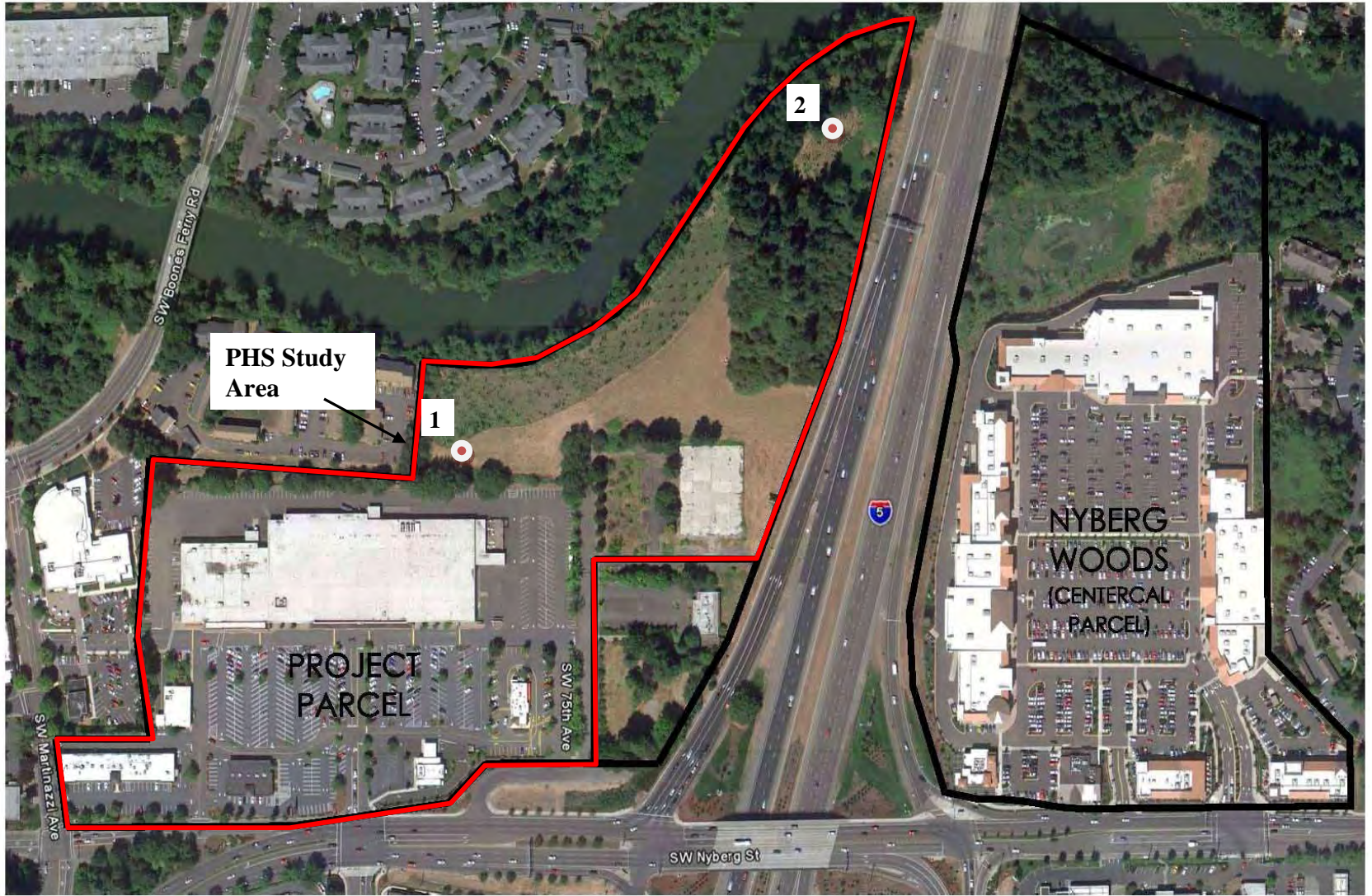

11/17/11

4921

FIGURE

1

Nyberg II, a proposed commercial development west of I-5 in Tualatin , Oregon (Air photo base map provided by Cardno WRG, 2011).

WETLAND DETERMINATION DATA FORM - Western Mountains, Valleys, and Coast Region

Project/Site: Nyberg II City/County: Tualatin/Washington Sampling Date: 11/15/2011

Applicant/Owner: Centercal State: OR Sampling Point: 1

Investigator(s): S. Eisner / A. Hawkins Section, Township, Range: Section 24B, T 2 South, R 1 West

Landform (hillslope, terrace, etc.): _____ Local relief (concave, convex, none): none Slope (%): _____

Subregion (LRR): LRR A Lat: 45.3849 Long: -122.7552 Datum: _____

Soil Map Unit Name: Chehalis silt loam NWI Classification: none

Are climatic/hydrologic conditions on the site typical for this time of year? Yes X No _____ (if no, explain in Remarks)

Are vegetation _____ Soil _____ or Hydrology _____ significantly disturbed? Are "Normal Circumstances" present? (Y/N) Y

Are vegetation _____ Soil _____ or Hydrology _____ naturally problematic? If needed, explain any answers in Remarks.)

SUMMARY OF FINDINGS – Attach site map showing sampling point locations, transects, important features, etc.

Hydrophytic Vegetation Present? Yes <u>X</u> No _____	Is Sampled Area within a Wetland? Yes _____ No <u>X</u>
Hydric Soil Present? Yes _____ No <u>X</u>	
Wetland Hydrology Present? Yes _____ No <u>X</u>	

Remarks:
Pit typical of existing conditions at west end of undeveloped area.

VEGETATION - Use scientific names of plants.

	absolute % cover	Dominant Species?	Indicator Status	
Tree Stratum (plot size: _____)				Dominance Test worksheet: Number of Dominant Species That are OBL, FACW, or FAC: <u>1</u> (A) Total Number of Dominant Species Across All Strata: <u>1</u> (B) Percent of Dominant Species That are OBL, FACW, or FAC: <u>100%</u> (A/B)
1	_____	_____	_____	
2	_____	_____	_____	
3	_____	_____	_____	
4	_____	_____	_____	
	<u>0</u>	= Total Cover		
Sapling/Shrub Stratum (plot size: _____)				
1	_____	_____	_____	
2	_____	_____	_____	
3	_____	_____	_____	
4	_____	_____	_____	
5	_____	_____	_____	
	<u>0</u>	= Total Cover		
Herb Stratum (plot size: <u>5</u>)				Prevalence Index Worksheet: Total % Cover of _____ Multiply by: _____ OBL Species _____ x 1 = <u>0</u> FACW species _____ x 2 = <u>0</u> FAC Species _____ x 3 = <u>0</u> FACU Species _____ x 4 = <u>0</u> UPL Species _____ x 5 = <u>0</u> Column Totals <u>0</u> (A) <u>0</u> (B) Prevalence Index =B/A = <u>#DIV/0!</u>
1	<u>90</u>	<u>X</u>	<u>FAC</u>	
2	<u>10</u>		<u>FACW</u>	
3	<u>1</u>		<u>(FAC)</u>	
4	_____	_____	_____	
5	_____	_____	_____	
6	_____	_____	_____	
7	_____	_____	_____	
8	_____	_____	_____	
	<u>101</u>	= Total Cover		
Woody Vine Stratum (plot size: _____)				
1	_____	_____	_____	
2	_____	_____	_____	
	<u>0</u>	= Total Cover		
% Bare Ground in Herb Stratum _____				
Hydrophytic Vegetation Indicators:				
_____ 1- Rapid Test for Hydrophytic Vegetation				
<u>X</u> 2- Dominance Test is >50%				
_____ 3-Prevalence Index is ≤ 3.0 ¹				
_____ 4-Morphological Adaptations ¹ (provide supporting data in Remarks or on a separate sheet)				
_____ 5- Wetland Non-Vascular Plants ¹				
_____ Problematic Hydrophytic Vegetation ¹ (Explain)				
¹ Indicators of hydric soil and wetland hydrology must be present, unless disturbed or problematic.				
Hydrophytic Vegetation Present? Yes <u>X</u> No _____				

Remarks:
This is a periodically mowed herbaceous area immediate south of presumed vegetative buffer enhancements south of the Tualatin River.

Profile Description: (Describe to the depth needed to document the indicator or confirm the absence of indicators.)

Depth (Inches)	Matrix		Redox Features				Texture	Remarks
	Color (moist)	%	Color (moist)	%	Type ¹	Loc ²		
0-16	10YR 3/3	40					Silt Loam	mixed matrix soil
0-16	10YR 3/4	60					Silt Loam	mixed matrix soil

¹Type: C=Concentration, D=Depletion, RM=Reduced Matrix, CS=Covered or Coated Sand Grains.

²Location: PL=Pore Lining, M=Matrix.

Hydric Soil Indicators: (Applicable to all LRRs, unless otherwise noted.)

Indicators for Problematic Hydric Soils³:

<input type="checkbox"/> Histosol (A1)	<input type="checkbox"/> Sandy Redox (S5)	<input type="checkbox"/> 2 cm Muck (A10)
<input type="checkbox"/> Histic Epipedon (A2)	<input type="checkbox"/> Stripped Matrix (S6)	<input type="checkbox"/> Red Parent Material (TF2)
<input type="checkbox"/> Black Histic (A3)	<input type="checkbox"/> Loamy Mucky Mineral (F1) (except MLRA 1)	<input type="checkbox"/> Very Shallow Dark Surface (TF12)
<input type="checkbox"/> Hydrogen Sulfide (A4)	<input type="checkbox"/> Loamy Gleyed Matrix (F2)	<input type="checkbox"/> Other (explain in Remarks)
<input type="checkbox"/> Depleted Below Dark Surface (A11)	<input type="checkbox"/> Depleted Matrix (F3)	
<input type="checkbox"/> Thick Dark Surface (A12)	<input type="checkbox"/> Redox Dark Surface (F6)	
<input type="checkbox"/> Sandy Mucky Mineral (S1)	<input type="checkbox"/> Depleted Dark Surface (F7)	
<input type="checkbox"/> Sandy Gleyed Matrix (S4)	<input type="checkbox"/> Redox Depressions (F8)	

³Indicators of hydrophytic vegetation and wetland hydrology must be present, unless disturbed or problematic.

Restrictive Layer (if present):

Type: None
 Depth (inches): _____

Hydric Soil Present? Yes _____ No X

Remarks:

HYDROLOGY

Wetland Hydrology Indicators:

Primary Indicators (minimum of one required; check all that apply)

Secondary Indicators (2 or more required)

<input type="checkbox"/> Surface Water (A1)	<input type="checkbox"/> Water stained Leaves (B9) (Except MLRA 1, 2, 4A, and 4B)	<input type="checkbox"/> Water stained Leaves (B9) (Except MLRA1, 2, 4A, and 4B)
<input type="checkbox"/> High Water Table (A2)	<input type="checkbox"/> Salt Crust (B11)	<input type="checkbox"/> Drainage Patterns (B10)
<input type="checkbox"/> Saturation (A3)	<input type="checkbox"/> Aquatic Invertebrates (B13)	<input type="checkbox"/> Dry-Season Water Table (C2)
<input type="checkbox"/> Water Marks (B1)	<input type="checkbox"/> Hydrogen Sulfide Odor (C1)	<input type="checkbox"/> Saturation Visible on Aerial Imagery (C9)
<input type="checkbox"/> Sediment Deposits (B2)	<input type="checkbox"/> Oxidized Rhizospheres along Living Roots (C3)	<input type="checkbox"/> Geomorphic Position (D2)
<input type="checkbox"/> Drift Deposits (B3)	<input type="checkbox"/> Presence of Reduced Iron (C4)	<input type="checkbox"/> Shallow Aquitard (D3)
<input type="checkbox"/> Algal Mat or Crust (B4)	<input type="checkbox"/> Recent Iron Reduction in Plowed Soils (C6)	<input type="checkbox"/> Fac-Neutral Test (D5)
<input type="checkbox"/> Iron Deposits (B5)	<input type="checkbox"/> Stunted or Stressed Plants (D1) (LRR A)	<input type="checkbox"/> Raised Ant Mounds (D6) (LRR A)
<input type="checkbox"/> Surface Soil Cracks (B6)	<input type="checkbox"/> Other (Explain in Remarks)	<input type="checkbox"/> Frost-Heave Hummocks (D7)
<input type="checkbox"/> Inundation Visible on Aerial Imagery (B7)		
<input type="checkbox"/> Sparsely Vegetated Concave Surface (B8)		

Field Observations:

Surface Water Present? Yes _____ No X Depth (inches): _____
 Water Table Present? Yes _____ No X Depth (inches): _____
 Saturation Present? Yes _____ No X Depth (inches): _____
 (includes capillary fringe)

Wetland Hydrology Present?

Yes _____ No X

Describe Recorded Data (stream gauge, monitoring well, aerial photos, previous inspections), if available:

None

Remarks:

WETLAND DETERMINATION DATA FORM - Western Mountains, Valleys, and Coast Region

Project/Site: Nyberg II City/County: Tualatin/Washington Sampling Date: 11/15/2011
 Applicant/Owner: Centercal State: OR Sampling Point: 2
 Investigator(s): S. Eisner / A. Hawkins Section, Township, Range: Section 24B, T 2 South, R 1 West
 Landform (hillslope, terrace, etc.): _____ Local relief (concave, convex, none): none Slope (%): _____
 Subregion (LRR): LRR A Lat: 45.3868 Long: -122.752 Datum: _____
 Soil Map Unit Name: Chehalis silt loam NWI Classification: none
 Are climatic/hydrologic conditions on the site typical for this time of year? Yes X No _____ (if no, explain in Remarks)
 Are vegetation _____ Soil _____ or Hydrology _____ significantly disturbed? Are "Normal Circumstances" present? (Y/N) Y
 Are vegetation _____ Soil _____ or Hydrology _____ naturally problematic? If needed, explain any answers in Remarks.)

SUMMARY OF FINDINGS – Attach site map showing sampling point locations, transects, important features, etc.

Hydrophytic Vegetation Present? Yes _____ No <u>X</u>	Is Sampled Area within a Wetland? Yes _____ No <u>X</u>
Hydric Soil Present? Yes _____ No <u>X</u>	
Wetland Hydrology Present? Yes _____ No <u>X</u>	

Remarks:
Pit taken in localized depression. Pit taken to document the most likely location for wetland to have been present in the forested portion of the site.

VEGETATION - Use scientific names of plants.

	absolute % cover	Dominant Species?	Indicator Status	
Tree Stratum (plot size: <u>30</u>)				Dominance Test worksheet: Number of Dominant Species That are OBL, FACW, or FAC: <u>1</u> (A) Total Number of Dominant Species Across All Strata: <u>4</u> (B) Percent of Dominant Species That are OBL, FACW, or FAC: <u>25%</u> (A/B)
1	<u>60</u>	<u>X</u>	<u>FACU</u>	
2	<u>10</u>		<u>FAC</u>	
3	<u>5</u>		<u>FACU</u>	
4				
	<u>75</u>	= Total Cover		
Sapling/Shrub Stratum (plot size: <u>5</u>)				
1	<u>15</u>	<u>X</u>	<u>FACU</u>	
2				
3				
4				
5				
	<u>15</u>	= Total Cover		
Herb Stratum (plot size: <u>5</u>)				Prevalence Index Worksheet: Total % Cover of _____ Multiply by: OBL Species _____ x 1 = <u>0</u> FACW species _____ x 2 = <u>0</u> FAC Species _____ x 3 = <u>0</u> FACU Species _____ x 4 = <u>0</u> UPL Species _____ x 5 = <u>0</u> Column Totals <u>0</u> (A) <u>0</u> (B) Prevalence Index =B/A = <u>#DIV/0!</u>
1	<u>20</u>		<u>UPL</u>	
2	<u>25</u>	<u>X</u>	<u>FAC</u>	
3	<u>10</u>		<u>FACW</u>	
4	<u>50</u>	<u>X</u>	<u>UPL</u>	
5	<u>tr</u>		<u>FAC</u>	
6	<u>3</u>		<u>UPL</u>	
7	<u>tr</u>		<u>FAC</u>	
8				
	<u>108</u>	= Total Cover		
Woody Vine Stratum (plot size: _____)				
1				
2				
	<u>0</u>	= Total Cover		
% Bare Ground in Herb Stratum <u>0</u>				
Hydrophytic Vegetation Indicators: _____ 1- Rapid Test for Hydrophytic Vegetation _____ 2- Dominance Test is >50% _____ 3-Prevalence Index is ≤ 3.0 ¹ _____ 4-Morphological Adaptations ¹ (provide supporting data in Remarks or on a separate sheet) _____ 5- Wetland Non-Vascular Plants ¹ _____ Problematic Hydrophytic Vegetation ¹ (Explain) ¹ Indicators of hydric soil and wetland hydrology must be present, unless disturbed or problematic. Hydrophytic Vegetation Present? Yes _____ No <u>X</u>				

Remarks:

Profile Description: (Describe to the depth needed to document the indicator or confirm the absence of indicators.)

Depth (Inches)	Matrix		Redox Features				Texture	Remarks
	Color (moist)	%	Color (moist)	%	Type ¹	Loc ²		
0-4	10YR 2/2	100					Loam	
4-17	10YR 3/3	100					Silt Loam	

¹Type: C=Concentration, D=Depletion, RM=Reduced Matrix, CS=Covered or Coated Sand Grains.

²Location: PL=Pore Lining, M=Matrix.

Hydric Soil Indicators: (Applicable to all LRRs, unless otherwise noted.)

Indicators for Problematic Hydric Soils³:

<input type="checkbox"/> Histosol (A1)	<input type="checkbox"/> Sandy Redox (S5)	<input type="checkbox"/> 2 cm Muck (A10)
<input type="checkbox"/> Histic Epipedon (A2)	<input type="checkbox"/> Stripped Matrix (S6)	<input type="checkbox"/> Red Parent Material (TF2)
<input type="checkbox"/> Black Histic (A3)	<input type="checkbox"/> Loamy Mucky Mineral (F1) (except MLRA 1)	<input type="checkbox"/> Very Shallow Dark Surface (TF12)
<input type="checkbox"/> Hydrogen Sulfide (A4)	<input type="checkbox"/> Loamy Gleyed Matrix (F2)	<input type="checkbox"/> Other (explain in Remarks)
<input type="checkbox"/> Depleted Below Dark Surface (A11)	<input type="checkbox"/> Depleted Matrix (F3)	
<input type="checkbox"/> Thick Dark Surface (A12)	<input type="checkbox"/> Redox Dark Surface (F6)	
<input type="checkbox"/> Sandy Mucky Mineral (S1)	<input type="checkbox"/> Depleted Dark Surface (F7)	
<input type="checkbox"/> Sandy Gleyed Matrix (S4)	<input type="checkbox"/> Redox Depressions (F8)	

³Indicators of hydrophytic vegetation and wetland hydrology must be present, unless disturbed or problematic.

Restrictive Layer (if present):

Type: None
 Depth (inches): _____

Hydric Soil Present? Yes _____ No X

Remarks:

HYDROLOGY

Wetland Hydrology Indicators:

Primary Indicators (minimum of one required; check all that apply)

Secondary Indicators (2 or more required)

<input type="checkbox"/> Surface Water (A1)	<input type="checkbox"/> Water stained Leaves (B9) (Except MLRA 1, 2, 4A, and 4B)	<input type="checkbox"/> Water stained Leaves (B9) (Except MLRA1, 2, 4A, and 4B)
<input type="checkbox"/> High Water Table (A2)	<input type="checkbox"/> Salt Crust (B11)	<input type="checkbox"/> Drainage Patterns (B10)
<input type="checkbox"/> Saturation (A3)	<input type="checkbox"/> Aquatic Invertebrates (B13)	<input type="checkbox"/> Dry-Season Water Table (C2)
<input type="checkbox"/> Water Marks (B1)	<input type="checkbox"/> Hydrogen Sulfide Odor (C1)	<input type="checkbox"/> Saturation Visible on Aerial Imagery (C9)
<input type="checkbox"/> Sediment Deposits (B2)	<input type="checkbox"/> Oxidized Rhizospheres along Living Roots (C3)	<input type="checkbox"/> Geomorphic Position (D2)
<input type="checkbox"/> Drift Deposits (B3)	<input type="checkbox"/> Presence of Reduced Iron (C4)	<input type="checkbox"/> Shallow Aquitard (D3)
<input type="checkbox"/> Algal Mat or Crust (B4)	<input type="checkbox"/> Recent Iron Reduction in Plowed Soils (C6)	<input type="checkbox"/> Fac-Neutral Test (D5)
<input type="checkbox"/> Iron Deposits (B5)	<input type="checkbox"/> Stunted or Stressed Plants (D1) (LRR A)	<input type="checkbox"/> Raised Ant Mounds (D6) (LRR A)
<input type="checkbox"/> Surface Soil Cracks (B6)	<input type="checkbox"/> Other (Explain in Remarks)	<input type="checkbox"/> Frost-Heave Hummocks (D7)
<input type="checkbox"/> Inundation Visible on Aerial Imagery (B7)		
<input type="checkbox"/> Sparsely Vegetated Concave Surface (B8)		

Field Observations:

Surface Water Present? Yes _____ No X Depth (inches): _____
 Water Table Present? Yes _____ No X Depth (inches): _____
 Saturation Present? Yes _____ No X Depth (inches): _____
 (includes capillary fringe)

Wetland Hydrology Present?

Yes _____ No X

Describe Recorded Data (stream gauge, monitoring well, aerial photos, previous inspections), if available:

None

Remarks:

Appendix C

Vegetated Corridor Sample Points Table & Photodocumentation



Nyberg Rivers Development Vegetated Corridor Sample Sites

Plant Community	A			B		C				
Sample Site	1	3	7	2	4	5	6			
TREES										
<i>Acer macrophyllum</i>				20	10		2			
<i>Alnus rubra</i>				40						
<i>Crataegus monogyna</i>				15			2			
<i>Pseudotsuga menziesii</i>				10	90		90	75		
<i>Thuja plicata</i>							30			
SHRUBS & SAPLINGS										
<i>Acer circinatum</i>	2									
<i>Acer macrophyllum</i>	5	1	5							
<i>Berberis aquifolium</i>	1	5	5		5		2	2		
<i>Crataegus douglasii</i>	10	10	10							
<i>Crataegus monogyna</i>	10			5			3			
<i>Oemleria cerasiformis</i>							1			
<i>Pseudotsuga menziesii</i>	20	20	20							
<i>Quercus garryana</i>	5	5	5							
<i>Rosa nutkana</i>	15	10	15							
<i>Rubus armeniacus</i>	1	1	5	25	1		10	25		
<i>Rubus ursinus</i>				5				25		
<i>Symphoricarpos albus</i>	2	2	5	15	20			5		
HERBS/WOODY VINES										
<i>Agrostis capillaris</i>	40	80	20		10					
<i>Anthoxantum odoratum</i>										
<i>Arrhenatherum elatius</i>										
<i>Berberis nervosa</i>	1									
<i>Cirsium arvense/vulgare</i>			5							
<i>Dactylus glomerata</i>	20	5	40		60		45	50		
<i>Daucus carota</i>	10									
<i>Festuca arundinacea</i>	5									
<i>Galium aparine</i>					5					
<i>Geranium lucidum</i>					10		10	20		
<i>Geranium molle</i>					5					
<i>Geranium robertianum</i>					5					
<i>Hedera helix</i>				100	2		20	10		
<i>Holcus lanatus</i>	5	10	30							
<i>Lapsana communis</i>				5			10	20		
<i>Plantago lanceolata</i>	2									
<i>Polystichum munitum</i>				10	1		1	2		
Unidentified grasses				5			20			
<i>Vicia</i> sp.		5			3					
	Average			Average			Average			
Canopy cover	0	0	0	0	90	95	93	90	85	88
% Native Species	40	34	39	38	39	58	48	44	53	48
% Invasive Species	1	1	6	2	49	1	25	14	13	14
Total cover	154	154	165	255	227	212	268			



Photo A:

View to the north in the western portion of the corridor. Foreground is Community A. The larger deciduous trees are part of Community B. The fir trees in the background are located across the Tualatin River and are not on the site.



Photo B:

View to the northeast from the eastern portion of Community A. The larger trees in the background are in Community C.

5141
3/8/13



Pacific Habitat Services, Inc.
9450 SW Commerce Circle, Suite 180
Wilsonville, OR 97070

Photo documentation of existing plant communities north of Nyberg Rivers.
Both photos taken on March 5, 2013.



Photo C:

View to the northeast along the south bank of the Tualatin River. Left side of the photo is Community B; the right side is Community A; and the background includes Community C.



Photo D:

View to the northeast across the western extent of Community C.

5141
3/8/13



Pacific Habitat Services, Inc.
9450 SW Commerce Circle, Suite 180
Wilsonville, OR 97070

Photo documentation of existing plant communities north of Nyberg Rivers.
Both photos taken on March 5, 2013.



Photo E:

View to the southwest
across the north end of
Community C.

Photo F:

View to the southwest of the
small area of Community A
within Community C.



5141
3/8/13



Pacific Habitat Services, Inc.
9450 SW Commerce Circle, Suite 180
Wilsonville, OR 97070

Photo documentation of existing plant communities north of Nyberg Rivers.
Both photos taken on March 5, 2013.

Appendix D

NRA Definitions and Methodology and References



NATURAL RESOURCE ASSESSMENT (NRA)

Regulatory Jurisdiction

Clean Water Services, as part of their revised Design and Construction Standards, requires that natural resource assessments be conducted for Sensitive Natural Resource Areas within their jurisdiction. Sensitive Natural Resource Areas include intermittent and perennial creeks, wetlands, springs and seeps, and associated vegetated corridors. The intent of these requirements is to "...prevent or reduce adverse impacts to the drainage system and water resources of the Tualatin River Basin" (CWS 2007). CWS requires a wetland determination/delineation and vegetated corridor assessment on projects that contain or are within 200 feet of a Sensitive Area.

Natural Resource Assessment Methodology

The Natural Resource Assessment (NRA) contains two components: a delineation of the water quality sensitive areas and a vegetated corridor evaluation. A detailed discussion of the methodology is included in Chapter 3 of CWS's revised Design and Construction Standards (CWS, 2007). A brief description of each component is included below.

Delineation of water quality sensitive areas

A delineation of all on-site water quality sensitive areas (wetland, intermittent/perennial streams, springs, and natural lakes or ponds) must be conducted. For wetlands, the required criteria and suggested methodologies of the *Corps of Engineers Wetland Delineation Manual Technical Report Y-87-1*, (Environmental Laboratory, 1987) must be used to delineate the boundaries. This manual defines wetlands as requiring indicators of hydric soils, a dominance of hydrophytic vegetation, and wetland hydrology. A determination as to whether streams are intermittent or perennial must be made. The extent of all streams, springs, and natural lakes or ponds must also be determined.

When known sensitive areas exist on adjacent properties, an attempt must be made by the applicant to obtain access to delineate the limits of these off-site features, especially if vegetated corridors associated with an off-site sensitive area may extend onto a proposed development site.

Determine Vegetated Corridor Width and Condition

The width of the vegetated corridor must be determined at least every 100 feet along the boundary of the water quality sensitive area. The corridor width can range between 15 and 200 feet and is measured horizontally from the outer edge of the water quality sensitive area. The boundaries of the sensitive areas and their vegetated corridors must be staked, surveyed, and mapped within the property and within 200 feet of the property line on a base map. The vegetated corridor width is based on the type of water resource (wetland, lake, stream), the size and nature of the water resource (acreage and/or perennial/intermittent), the size of the watershed, and the adjacent slope.

Upon identification of the regulated vegetated corridor boundary, the existing condition of the vegetated corridor must also be determined. This is accomplished by 1) identifying the plant community types present in the vegetated corridor, 2) documenting representative sample points, 3) characterizing each plant community type, 4) determining the cover by native species, invasive species, and noxious plants, and 5) based on this information determining whether the existing vegetated corridor condition for each plant community is good, marginal, or degraded.

REFERENCES

Clean Water Services, 2007. *Design and Construction Standards (R&O 7-20)*.

US Geologic Survey, 1984. *7.5-minute topographic map, Beaverton, Oregon quadrangle*.

US Geologic Survey, 1984. *7.5-minute topographic map, Lake Oswego, Oregon quadrangle*.

Nyberg Rivers
 Neighborhood Meeting
SIGN IN SHEET
 March 20, 2013

Name	Address: Street, Zip	Phone Number	E-Mail Address
CANDICE KELLY	8720 SW Tualatin Rd	503-691-1155	CANDICE.KELLY@msw.com
Carol Dersham	" "	503-612-1984	
Delilah R. Judy	8530 SW Sagert	503-692-6407	deljudy@frontier.com
JUNE BENNETT	18755 SW 90th AVE #422		
Roy Loop	21090 SW 86th Ct.	503-961-2701	roy@rloop.com
Jan Giunta	17655 SW Shownee Tr	612-9170	jan.giunta@gmail.com
LEE LEIGHTON	15115 SW SEQUOIA PKWY	503 684-0652	
WESTLAKE CONSULTANTS	S/E 150 TG 97224		LLEIGHTON@WESTLAKECONSULTANTS.COM
Aquilla Hurd-Rawn	93880 SW Martinuzzi Ave	on file	
SARA SINGER	18880 SW Martinuzzi Ave		ssinger@ci.tualatin.or.us
Aaron Weik	18735 SW Bonne Ferry Rd	503-704-4026	aweik@CascadeEndo.com
JACKI HERB	21587 SW 99th Ave	503 944 9601	jacki-herb@yahoo.com
DAVID CARNEY	19705 S.W. Teton	503-348-4550	dcarney@TualatinAireBody.com
GARY HABERMAN	18791 SW Martinuzzi	503-310-5159	habermangary11@gmail.com
Tommy Plumbo	9510 SW Siustaw Ln Tral		tmpgarden@comcast.net
Michael-Marissa Hausberg	9199 SW Conville Ct		marissa@HausbergDevelopment.com
NANCY GRIMES	19710 SW 96th Ct	903-318-6424	
WAYNE BROSMAN	18710 SW B.F. RD, TUAL. 97062	503 692 1062	WAYNE.BROSMAN@comcast.net

COMMENT FORM

Name*: J. Schwartz
Address*: 21238 SW 90 Ave Tualatin
Phone*: 691-2868
May We Contact you: ✓

Comment: Overall looks
Concern: Traffic in/out.
Already have congestion.
This will contribute to
move!

*Name, Phone & Address Optional



COMMENT FORM

Name*: ALAN CAMPBELL
Address*: 8728 SW PAMLICO
Phone*: 503-502-6302
May We Contact you: yes.

Comment: This projects does not meet its intended
promotional publicity of making use + giving
useful access to the Tualatin River. Cabela's
+ the developer have turned their back on
the river. The NE corner of Cabela's + the
adjacent parking area should focus attention
+ give access to the Tualatin. A path easement
is not sufficient
to justify a 75 year impact of the proposed project.

*Name, Phone & Address Optional



COMMENT FORM

Name*: Marissa Houlberg

Address*: 9789 SW Conville Ct

Phone*: _____

May We Contact you: Yes

Comment: You are building a strip mall/extended
pkg lot. The trail faces the 'back' of the
buildings. Your 'A' street takes pkg from
our library workers. Facades are not enough.
You ride on the success of Bridgeport Village but
Nyberg Woods & Nyberg River are nothing like it!

**Name, Phone & Address Optional*





Conceptual Pedestrian, Bicycle Routes and Shared Pathway Plan - Board #3

- Concerns on loading zones backing up to the river.
- Concerns of the views of the backs of buildings from the shared path.
- Too much parking.
- Not supportive of Street "A" taking library parking.
- Prefer to river access emphasis or across too.
- Where is City Council going?
- Suggestion for "Park-n-Ride" Considerations.

**NEIGHBORHOOD/DEVELOPER MEETING
AFFIDAVIT OF MAILING**

STATE OF OREGON)
) SS
COUNTY OF WASHINGTON)

I, Thatch Moyle , being first duly sworn, depose and say:

That on the 4th day of March , 2013, I served upon the persons shown on Exhibit "A," attached hereto and by this reference incorporated herein, a copy of the Notice of Neighborhood/Developer meeting marked Exhibit "B," attached hereto and by this reference incorporated herein, by mailing to them a true and correct copy of the original hereof. I further certify that the addresses shown on said Exhibit "A" are their regular addresses as determined from the books and records of the Washington County and/or Clackamas County Departments of Assessment and Taxation Tax Rolls, and that said envelopes were placed in the United States Mail with postage fully prepared thereon.



Signature

SUBSCRIBED AND SWORN to before me this 8th day of March , 2012.

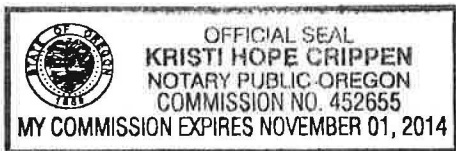



Notary Public for Oregon
My commission expires: 11-1-14

RE: NYBERG RIVERS

NEIGHBORHOOD/DEVELOPER MEETING
PUBLIC NOTICE MAILING

As the applicant for the NYBERG RIVERS MASTER PLAN
project, I hereby certify that on March 4th, 2013, notice of the Neighborhood /
Developer meeting was mailed in accordance with the requirements of the
Tualatin Development Code and the Community Development Department -
Planning Division.

Applicant's Name: THATCH MOYLE
(PLEASE PRINT)

Applicant's Signature: 

Date: 3/5/2013

NEIGHBORHOOD/DEVELOPER MEETING
PUBLIC NOTICE POSTING

As the applicant for the NYBERG RIVERS MASTER PLAN
project, I hereby certify that on March 6th, 2013, Four (4) sign(s)
were posted on the subject property in accordance with the requirements of the
Tualatin Development Code and the Community Development Department -
Planning Division.

Applicant's Name: THATCH MOYLE
(PLEASE PRINT)

Applicant's Signature: 

Date: 3/6/2013

MP-13-01

To lessen the bulk of the notice of application and to address privacy concerns, this sheet substitutes for the photocopy of the mailing labels. A copy is available upon request.



March 4, 2013

5415 SW Westgate Drive
Suite 100
Portland, Oregon 97221
USA

Phone (503) 419-2500
Fax (503) 419-2600

Re: Master Plan Application for Nyberg Rivers redevelopment

www.cardno.com

Dear Property Owner/Neighborhood Representative:

You are cordially invited to attend a meeting on March 20th, 2013 from 5 p.m. to 7 p.m. at the Umpqua Bank branch located at 18757 SW Martinazzi Ave in Suite 100. This meeting shall be held to discuss a proposed master plan application located at 7655 Nyberg Wood Road in Tualatin.

Please note that this will be an informational meeting on preliminary plans with the developer and representatives only and is not intended to take the place of a public hearing before the Planning Commission. You will have an opportunity to present testimony to these bodies when an application is submitted to the City for review.

We look forward to meeting you at the March 20th meeting and hearing your thoughts on the proposed project!

Sincerely,

Thatch Moyle, AICP
Senior Planner, Cardno WRG

Enclosure: Site Plan



200 Feet 

Nyberg Rivers

Public Noticing-- Sign Locations

Tualatin, Oregon

MP-13-01 Attachment 102B, page 506





West side of SW 75th Ave entrance—looking west



West side of SW 75th Ave entrance—looking NW



Central entrance from Nyberg—looking NE



Central entrance from Nyberg—looking west



Western entrance from Nyberg—looking NW



Western entrance from Nyberg—looking NE



Martinazzi entrance looking north



Martinazzi entrance looking NE